

| P | LTR | DESCRIPTION | DATE | DWN | APVD |
|---|-----|---------------------|-----------|-----|------|
| 1 | | PRELIMINARY RELEASE | 27JUN2022 | JSD | NS |
| 2 | | MODEL UPDATED | 29JUL2022 | JSD | NS |
| A | | PRODUCTION RELEASE | 02APR2024 | MG | NS |

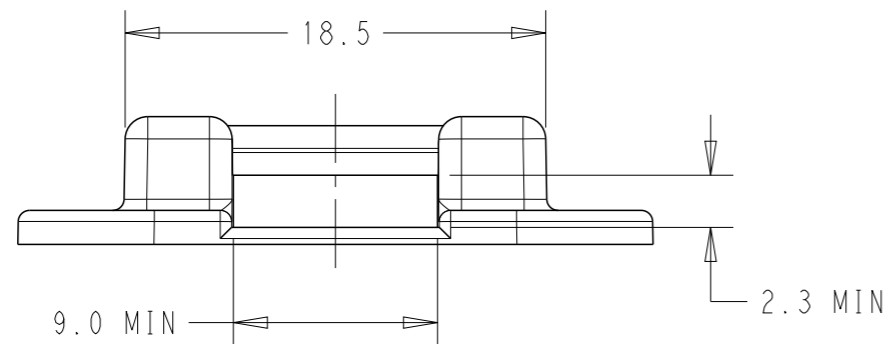
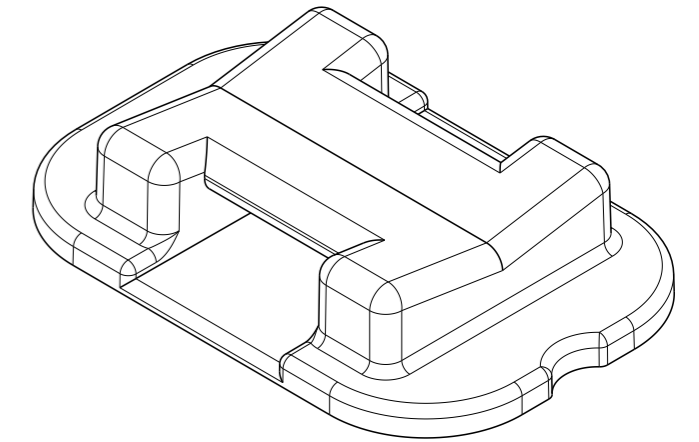
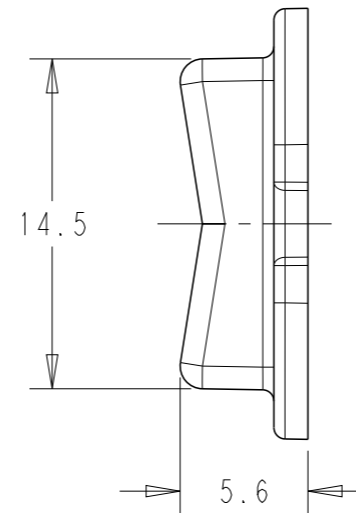
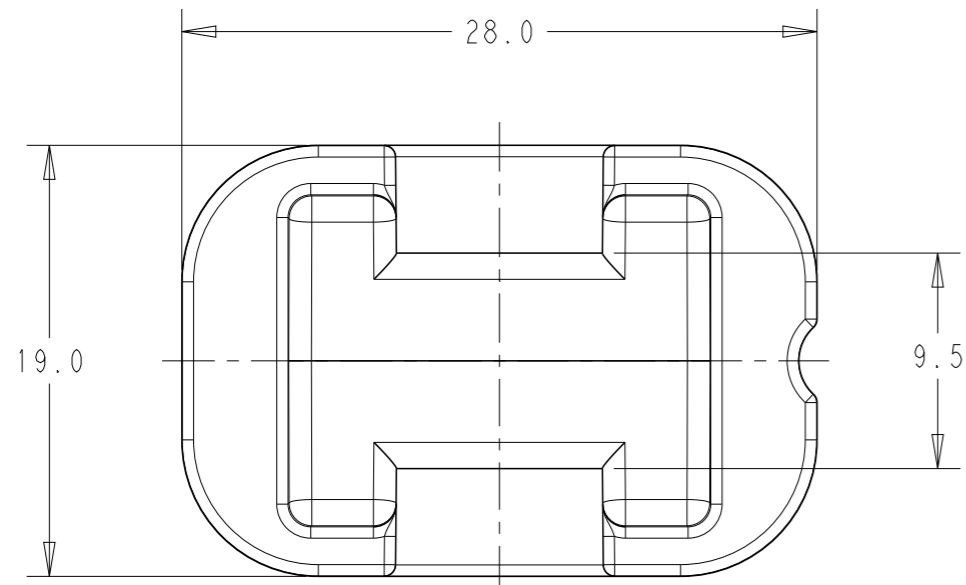

ORDERING INFORMATION

| | | |
|-------------------------------------|---------|----------------------------|
| CABLE-TIE ADHESIVE BRACKET STANDARD | CABS-XX | MATERIAL CODE |
| | | M1 - POLYETHERIMIDE 40% GF |

NOTES:

1. USE WITH CABLE TIE SIZE UP TO 7 PER MS3367.
2. MAX. CABLE BUNDLE DIAMETER OF 2 INCHES.

| | | | | | | | | | | | | | | | | |
|--|------|-------------------------------|----------------------------------|-------------------------|------|-------|----|-------|----|-------|----|--------|----|----------------------------|---------------|--|
| THIS DRAWING IS A CONTROLLED DOCUMENT. | | DWN JEEVAN 17JUN2022 | | | | | | | | | | | | | | |
| DIMENSIONS: mm | | CHK M GOWDA 27JUN2022 | | | | | | | | | | | | | | |
| TOLERANCES UNLESS OTHERWISE SPECIFIED: | | APVD SUDHAKAR 27JUN2022 | NAME STANDARD CABLE TIE MOUNT | | | | | | | | | | | | | |
| <table border="0"> <tr> <td>0 PLC</td> <td>±-</td> </tr> <tr> <td>1 PLC</td> <td>±0.3</td> </tr> <tr> <td>2 PLC</td> <td>±-</td> </tr> <tr> <td>3 PLC</td> <td>±-</td> </tr> <tr> <td>4 PLC</td> <td>±-</td> </tr> <tr> <td>ANGLES</td> <td>±-</td> </tr> </table> | | 0 PLC | ±- | 1 PLC | ±0.3 | 2 PLC | ±- | 3 PLC | ±- | 4 PLC | ±- | ANGLES | ±- | PRODUCT SPEC 108-160611 | RESTRICTED TO | |
| 0 PLC | ±- | | | | | | | | | | | | | | | |
| 1 PLC | ±0.3 | | | | | | | | | | | | | | | |
| 2 PLC | ±- | | | | | | | | | | | | | | | |
| 3 PLC | ±- | | | | | | | | | | | | | | | |
| 4 PLC | ±- | | | | | | | | | | | | | | | |
| ANGLES | ±- | | | | | | | | | | | | | | | |
| MATERIAL SEE MAT. CODE | | FINISH - | APPLICATION SPEC - | SIZE A3 | | | | | | | | | | | | |
| | | WEIGHT - | APPLICATION SPEC - | CAGE CODE 00779 | | | | | | | | | | | | |
| | | | APPLICATION SPEC - | DRAWING NO C=CABS-XX | | | | | | | | | | | | |
| | | | | SCALE 3:1 | | | | | | | | | | | | |
| | | | | SHEET 1 OF 1 | | | | | | | | | | | | |
| | | | | REV A | | | | | | | | | | | | |
| | | | | CUSTOMER DRAWING | | | | | | | | | | | | |