

| LDC | DIST | REVISIONS |            |                              |            |              |              |
|-----|------|-----------|------------|------------------------------|------------|--------------|--------------|
|     |      | P         | LTR<br>REV | DESCRIPTION<br>MODIFICATIONS | DATE       | DWN<br>DESS. | APVD<br>APPR |
| FH  | 00   |           | A          | Creation                     | 05-Janv-11 | GC           | GP           |
|     |      |           |            |                              |            |              |              |
|     |      |           |            |                              |            |              |              |

**MARQUAGE/MARKING:**

Reference Logo Lot Outil  
Reference Logo Batch Die

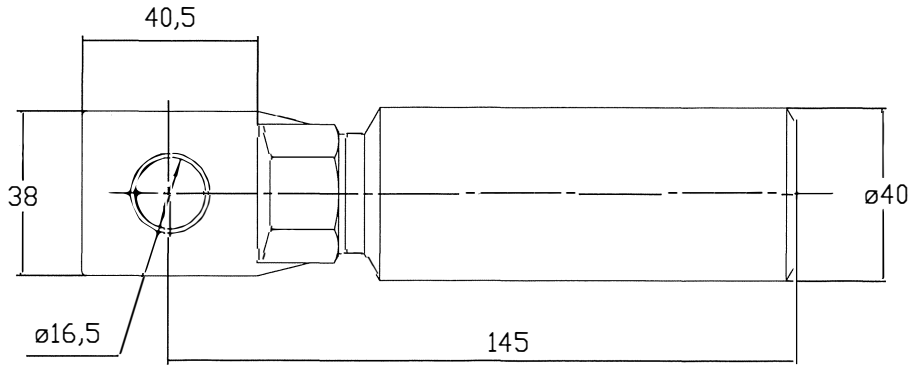
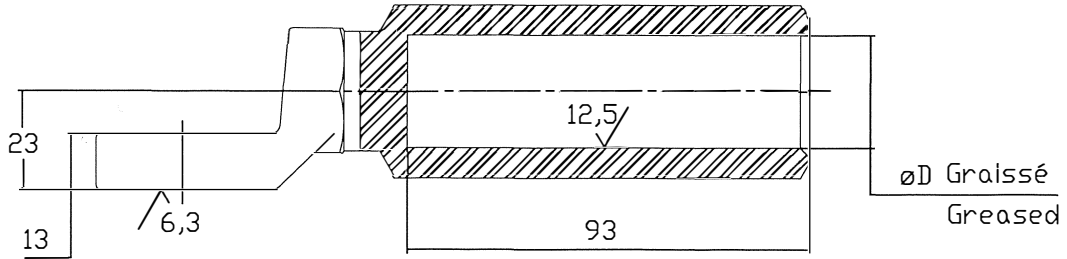

| PN        | REFERENCE       | SECTION<br>mm <sup>2</sup> | DIMENSIONS |          |
|-----------|-----------------|----------------------------|------------|----------|
|           |                 |                            | øD         | DIE      |
| 1306867-1 | XD8 300 C5A 300 | 300                        | 23,3       | MC-5E 5E |
| 1306868-1 | XD8 400 C5A 400 | 400                        | 26         |          |

RELEASED FOR PUBLICATION

ALL RIGHTS RESERVED.  
Tous droits réservés

BY TYCO ELECTRONICS CORPORATION

© COPYRIGHT 2007

THIS DRAWING IS UNPUBLISHED.  
DIFFUSION RESTREINTE

|  |  |   |   |                              |                            |                |
|--|--|---|---|------------------------------|----------------------------|----------------|
| DIMENSIONS:<br>mm  | DWN /DESSINE<br>G.CARLHIAN                         | - | MATERIAL<br>MATIERE   | ALU 1050A                    | FINISH<br>FINITION         | -              |
|  | CHK /VERIFIE<br>E.DEREY                            | - |  TE Connectivity<br>SIMEL PRODUCTS |                              |                            |                |
| TOLERANCES UNLESS<br>OTHERWISE SPECIFIED PER<br>TOLERANCES NON SPECIFIEES<br>SELEN I - | APVD /APPROUVE<br>G.PORCHERAY                      | - |   |                              |                            |                |
|  | PRODUCT SPEC<br>SPEC. PRODUIT                      | - | SIZE<br>FORMAT  | A4                           | DRAWING NO<br>No PLAN      | C=1306867      |
|  | APPLICATION SPEC<br>SPEC. APPLICATION<br>C33-090-1 | - | CAGE CODE   | 00779                        | RESTRICTED TO<br>RESERVE A | -              |
|  | APPROX. WEIGHT<br>MASSE APPROX.                    | - | DRAWING NO<br>No PLAN   | C=1306867                    | SCALE<br>ECHELLE           | 1:1            |
|  |  |   | CUSTOMER DWG / PLAN CLIENT  | UNIQUEMENT<br>POUR REFERENCE | SHEET<br>FEUILLE           | 1 OF 1<br>DE 1 |
|  |  |   |   |                              | REV                        | A              |