

| P | LTR | DESCRIPTION | DATE | DWN | APVD |
|---|-----|-------------|-----------|-----|------|
| 1 | | NEW LAYOUT | 09JUN2020 | SB | NJ |

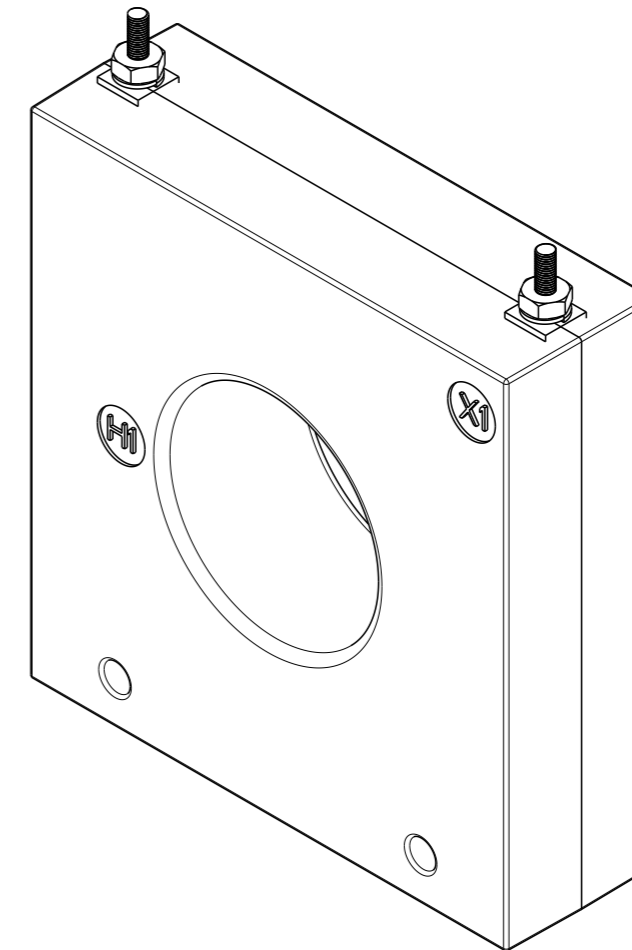
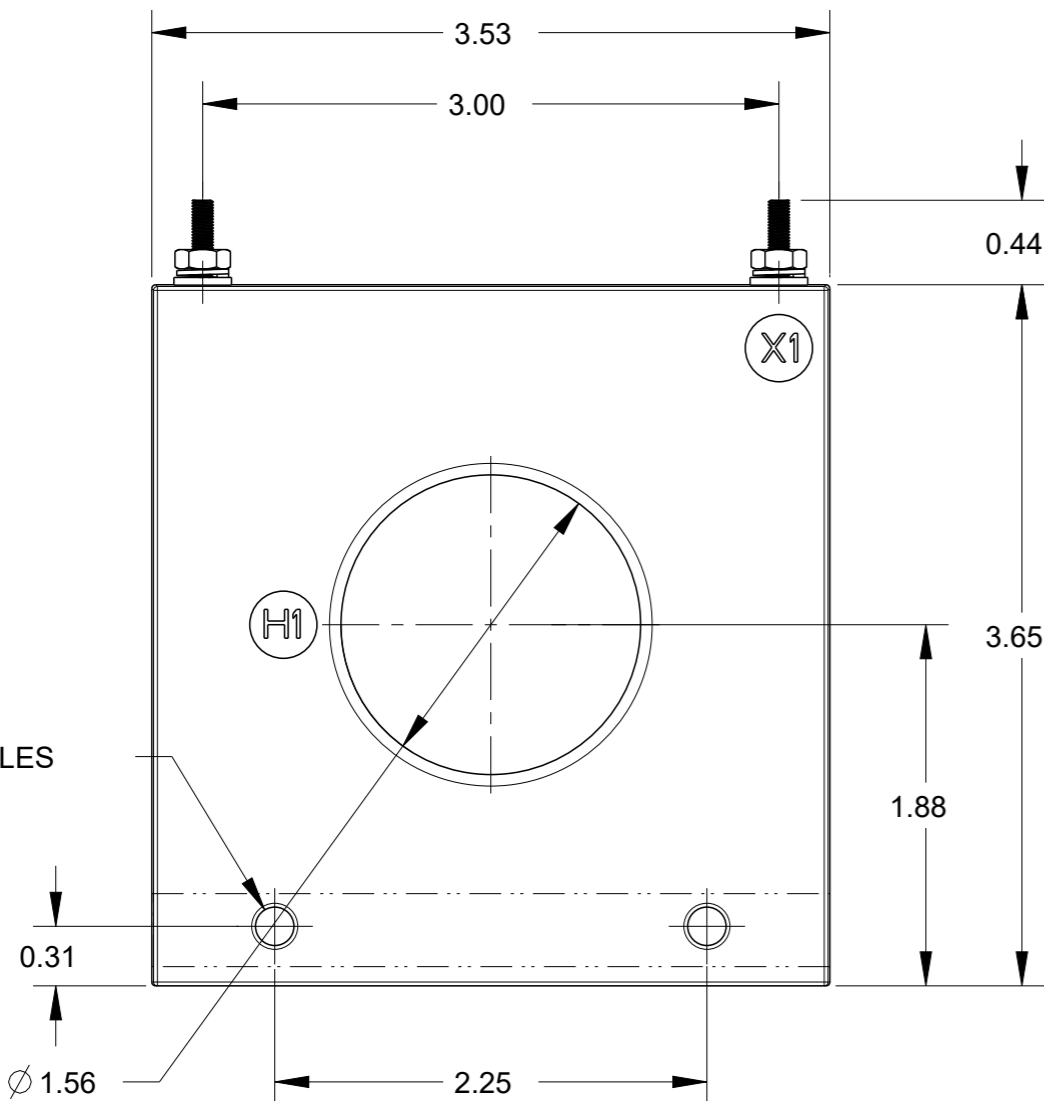
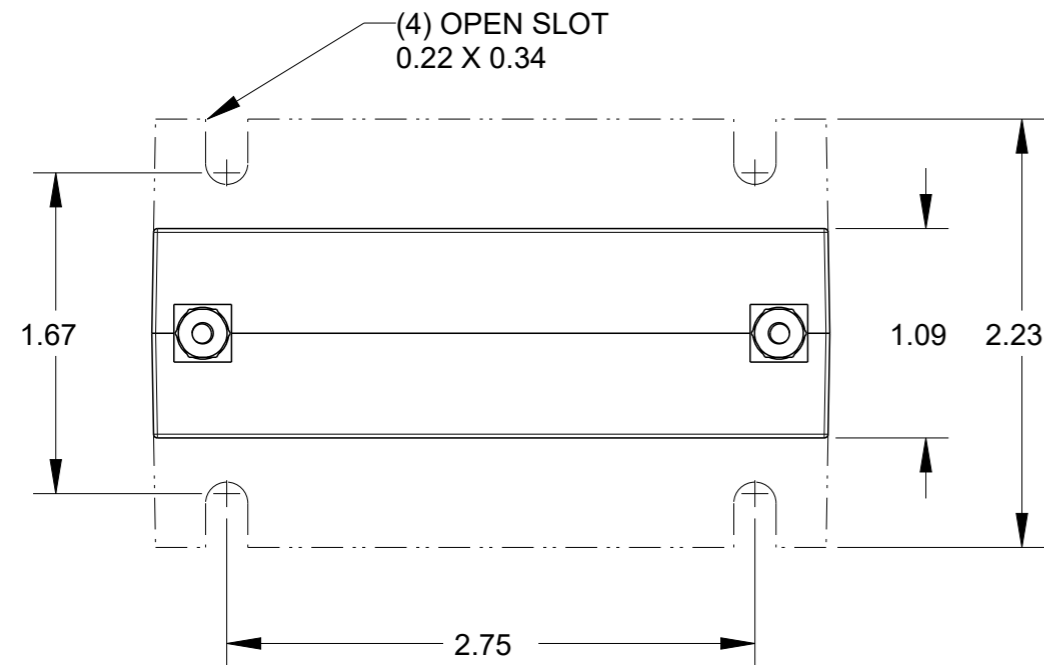

THIS DRAWING IS A CONTROLLED DOCUMENT.

| DIMENSIONS: | TOLERANCES UNLESS OTHERWISE SPECIFIED: |
|-----------------|--|
| in | |
| | 0 PLC ±- |
| | 1 PLC ±- |
| | 2 PLC ±- |
| | 3 PLC ±- |
| | 4 PLC ±- |
| | ANGLES ± |
| MATERIAL TBD | FINISH - |

| | |
|------------------|-----------|
| DWN | 08JUN2020 |
| SHRICHARANA B | |
| CHK | 08JUN2020 |
| NIGEL JOHNSON | |
| APVD | 08JUN2020 |
| NIGEL JOHNSON | |
| PRODUCT SPEC | - |
| APPLICATION SPEC | - |
| WEIGHT | - |
| CUSTOMER DRAWING | |

| | | | |
|-------|-----------|---|---------------|
| | | NAME | |
| | | ANSI CT - MODEL 5SHT DIMENSIONAL DRAWING | |
| SIZE | CAGE CODE | DRAWING NO | RESTRICTED TO |
| A3 | 00779 | C=CI-3L51601 | - |
| SCALE | | SHEET | REV |
| 1:1 | | 1 OF 1 | 1 |