

REVISIONS				
P	LTR	DESCRIPTION	DATE	APVD
	A1	REVISED AS PER ECN-21-122519	19OCT2021	RB LR

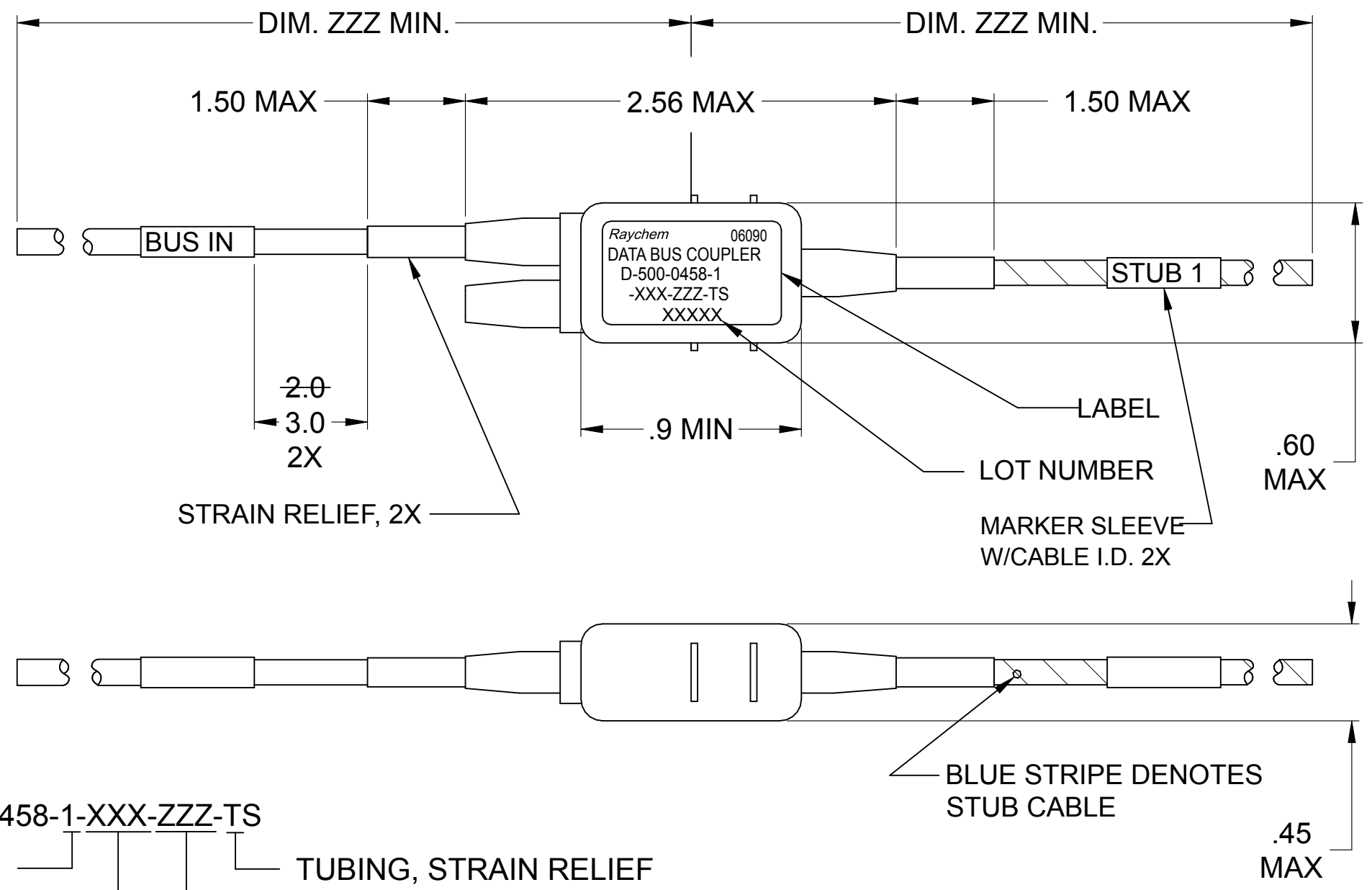

PART NO. D-500-0458-1-XXX-ZZZ-TS

1=SINGLE STUB

TUBING, STRAIN RELIEF

LENGTH OF CABLE IN INCHES

CABLE

- 612=10612 (SINGLE OPTIMIZED BRAID)
- 613=10613 (DOUBLE OPTIMIZED BRAID)
- 614=10614 (EMP HARDENED)

THIS DRAWING IS A CONTROLLED DOCUMENT.		DWN	RANJITHA B	19OCT2021	<b>STE</b> TE Connectivity			
DIMENSIONS: INCHES		CHK	P. TALLY	19OCT2021				
TOLERANCES UNLESS OTHERWISE SPECIFIED:		APVD	L. RODRIGUEZ	19OCT2021	NAME DATABUS COUPLER SINGLE STUB IN-LINE W/CABLE STRAIN RELIEF, REVERSE CABLE ORIENTATION WITH INTERNAL TERMINATOR			
0 PLC ± -		PRODUCT SPEC	-		SIZE	CAGE CODE	DRAWING NO	RESTRICTED TO
1 PLC ± -		APPLICATION SPEC	-		A3	06090	D-500-0458-1-XXX-ZZZ-TS	-
2 PLC ± -		WEIGHT	-		CUSTOMER DRAWING			SCALE
3 PLC ± -		MATERIAL		-		DNS		SHEET
4 PLC ± -		FINISH		-		1 OF 2		REV
ANGLES ± -		-		-		A1		

REVISIONS					
P	LTR	DESCRIPTION	DATE	DWN	APVD
-	-	SEE SHEET 1	-	-	-

1. MATERIAL AND FINISHES:

1.1 INTERNAL COMPONENTS:

- 1.1.1 -TRANSFORMER TO MIL-PRF-21038 AND MIL-STD-1553B
- 1.1.2 -RESISTORS, ISOLATION PER MIL-PRF-39007/9, 57.6 OHMS (R1)
- 1.1.3 -RESISTORS, TERMINATION PER MIL-PRF-39007/9, 76.8 OHMS (R2)
- 1.2 SHIELDED CASE: ALUMINUM PER ASTM-B618
- 1.3 SEALED STRAIN RELIEF COVER: MODIFIED CROSS-LINKED ELASTOMER, BLACK, TO RAYCHEM SPECIFICATION RK-6713.
- 1.4 CABLE TYPE PER RAYCHEM SPECIFICATION 1200 (SEE PART NO. ON SHEET 1).
- 1.5 STRAIN RELIEF TUBING: RAYCHEM TAT-125.

2. APPLICATION:

- 2.1 THIS COUPLER IS DESIGNED TO BE INSTALLED AS A DIGITAL MULTIPLEX ASSEMBLY MEETING THE REQUIREMENTS OF MIL-STD-1553B.
- 2.2 FOR CABLE SPLICING USE FLEXIBLE SPLICE KIT D-150-0708-5 (NOT SUPPLIED).
- 2.3 CABLE BEND RADIUS PER SAE-AS50881 STATIC BEND: 5 x CABLE O.D. MIN.  
DYNAMIC BEND: 10 x CABLE O.D. MIN.

3. TEMPERATURE:

- 3.1 OPERATING TEMPERATURE: -65°C TO +150°C

4. PERFORMANCE SPECIFICATIONS:

- 4.1 TRANSFORMER MEETS THE PERFORMANCE REQUIREMENTS OF MIL-STD-1553B.
- 4.2 COUPLER MEETS THE PERFORMANCE REQUIREMENTS OF RAYCHEM SPECIFICATION D-6020.

5. WEIGHT:

- 5.1 MAXIMUM WEIGHT WITHOUT CABLE: 13 GRAMS MAX.

SINGLE STUB COUPLER SCHEMATIC

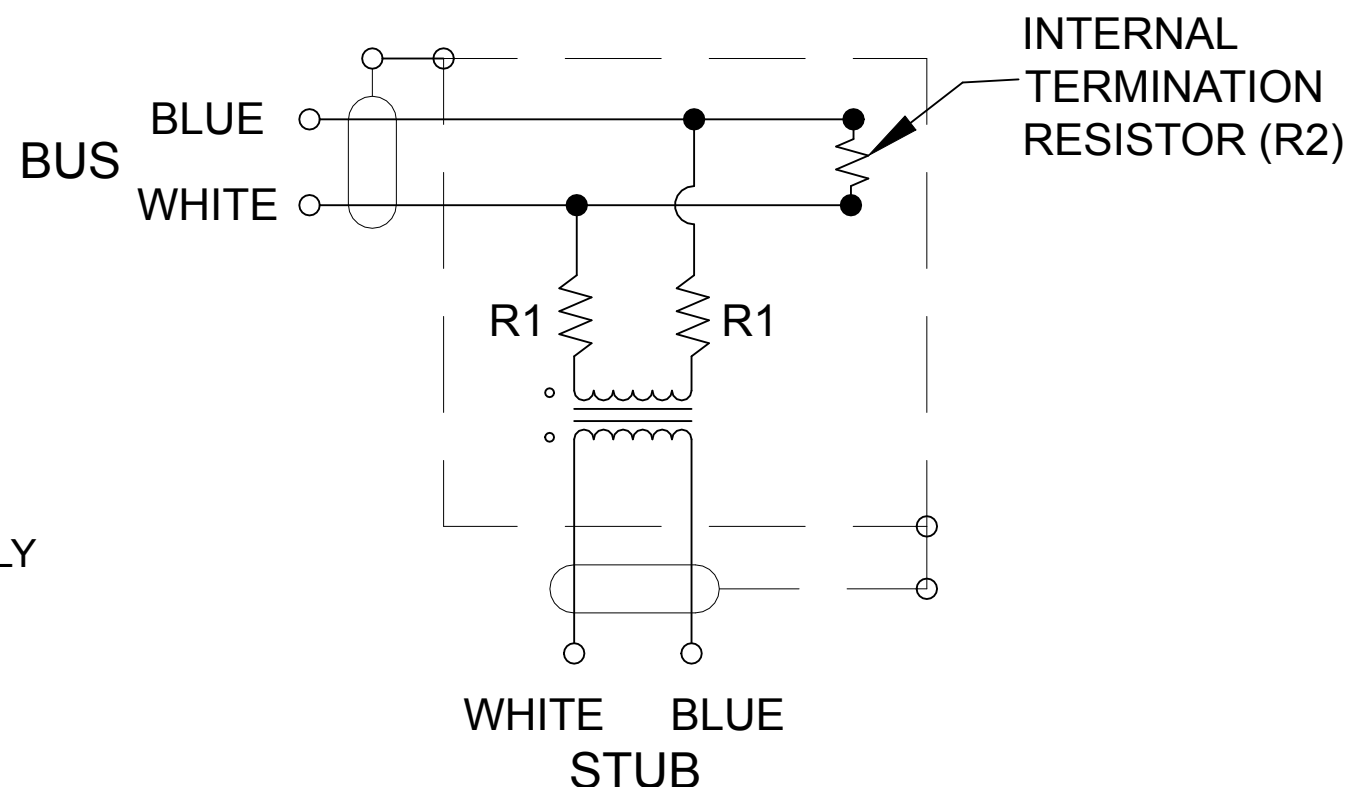

THIS DRAWING IS A CONTROLLED DOCUMENT.		DWN RANJITHA B 19OCT2021	TE Connectivity														
DIMENSIONS: INCHES		CHK P. TALLY 19OCT2021															
TOLERANCES UNLESS OTHERWISE SPECIFIED:		APVD L. RODRIGUEZ 19OCT2021	NAME DATABUS COUPLER SINGLE STUB IN-LINE W/CABLE STRAIN RELIEF, REVERSE														
<table border="1"> <tr><td>0 PLC</td><td>± -</td></tr> <tr><td>1 PLC</td><td>± -</td></tr> <tr><td>2 PLC</td><td>± -</td></tr> <tr><td>3 PLC</td><td>± -</td></tr> <tr><td>4 PLC</td><td>± -</td></tr> <tr><td>ANGLES</td><td>± -</td></tr> </table>		0 PLC	± -	1 PLC	± -	2 PLC	± -	3 PLC	± -	4 PLC	± -	ANGLES	± -	PRODUCT SPEC -	-		
0 PLC	± -																
1 PLC	± -																
2 PLC	± -																
3 PLC	± -																
4 PLC	± -																
ANGLES	± -																
MATERIAL -		FINISH -	APPLICATION SPEC -	SIZE A3	CAGE CODE 06090	DRAWING NO C-D-500-0458-1-XXX-ZZZ-TS	RESTRICTED TO -										
CUSTOMER DRAWING			WEIGHT 0.000000	SCALE DNS	SHEET 2 OF 2	REV A1											