

NOTES:

1. MARKED WITH TE PART NUMBER, CAGE CODE AND DATE CODE.

PART NUMBER EXAMPLE: D369 - B 3 3 - N P 4 - 119P

BASIC PART NUMBER: D369 - B 3 3
 SHELL STYLE (B = PANEL MOUNT RECEPTACLE 90°)
 SHELL SIZE: 3
 CONTACT QUANTITY (3=3 x #22, 6=6 x #22, 9=9 x #22)

MOD CODE (SEALED): N P 4
 CONTACT CONFIGURATION (0-3 = INLINE CONNECTOR, SEE SHEET 3) 9
 (4= 90° GOLD PLATED PCB TAIL)
 (5= 90° GOLD PLATED, TIN DIPPED PCB TAIL)
 CONTACT TYPE (P=PIN, S=SKT)
 SHELL KEYING

2. PERFORMANCE:

TEMPERATURE RANGE	-55°C TO +175°C
DIELECTRIC WITHSTAND VOLTAGE (AT SEA LEVEL)	1500VRMS <2ma LEAKAGE
DURABILITY	500 MATING CYCLES MIN.
INSULATION RESISTANCE	≥5000 MΩ INITIAL
ALTITUDE	RTCA DO160 - CATEGORY A4 (15,000ft)
HUMIDITY	RTCA DO160 - CATEGORY A

3. MATERIALS:

COMPONENT	MATERIAL (FINISH: CLEAN IN ALL CASES)
SEALS	SILICONE / FLUOROSILICONE BLEND RUBBER
BODY / INSERT COMPONENTS	THERMOPLASTIC
CONTACTS	COPPER ALLOY, SEE NOTE 1 FOR FINISH

4. THESE CONNECTORS ARE ROHS COMPLIANT

5. MAXIMUM WEIGHTS:

3 WAY - 7.1g (PIN INSERT), 7.1g (SOCKET INSERT).
 6 WAY - 7.9g (PIN INSERT), 7.9g (SOCKET INSERT).
 9 WAY - 8.7g (PIN INSERT), 8.7g (SOCKET INSERT).

6. SHELL KEYING:

SHELL KEYING (ALL SIZES)	
ORIENTATION	COLOUR
N	BLACK
A	DARK RED
B	DARK BLUE
C	DARK GREEN
D	YELLOW

7. DIMENSIONS:

SHELL SIZE	DIM 'A' MAX.	DIM 'B' MAX.
3	13.5	26.8
6	16.0	29.4
9	18.6	32.0

8. RECOMMENDED PANEL THICKNESS = 1.60mm (FOR REFERENCE ONLY). REFER TO INSTRUCTION SHEET 408-32194 FOR PANEL CUTOUT DIMENSIONS.

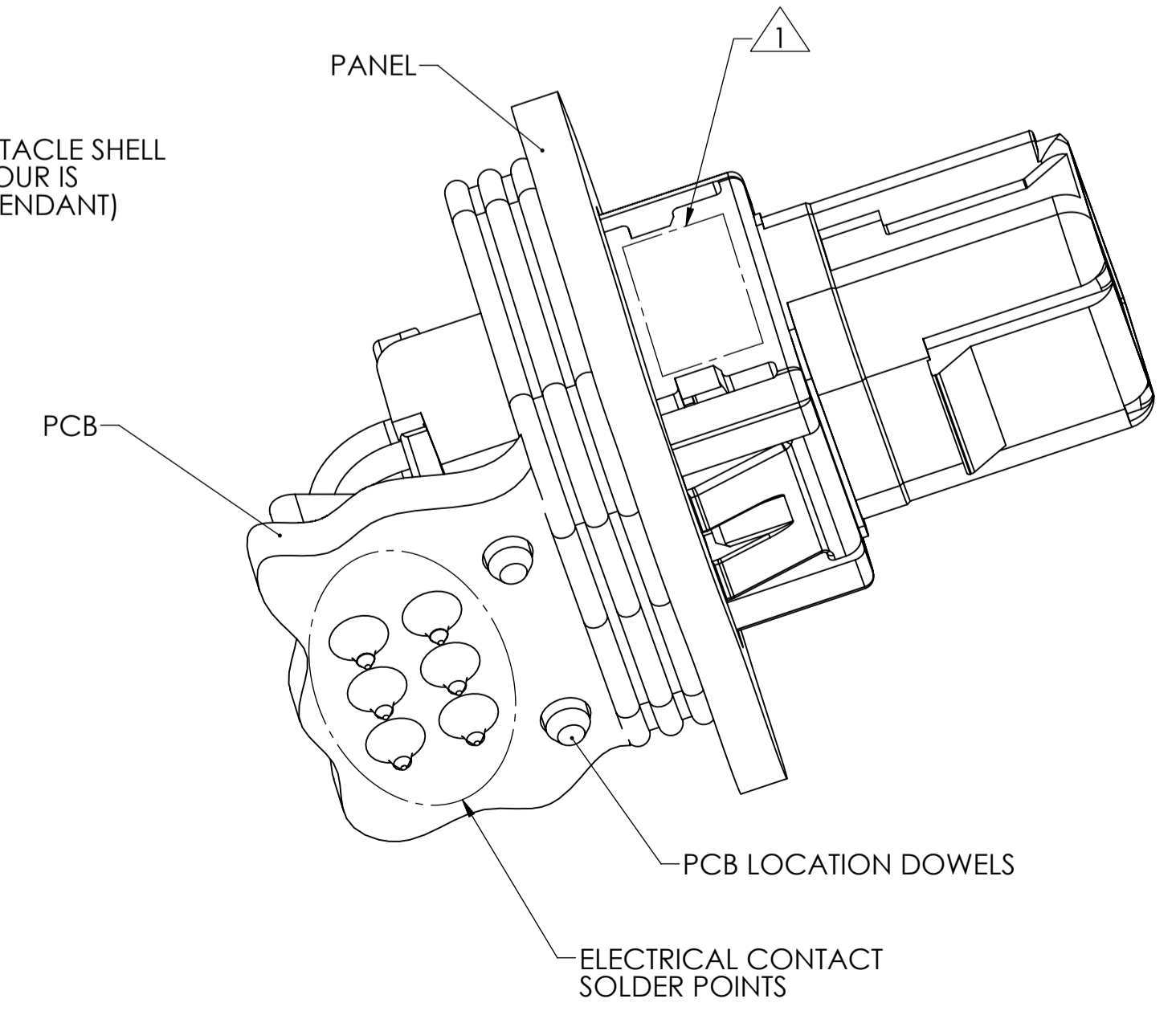
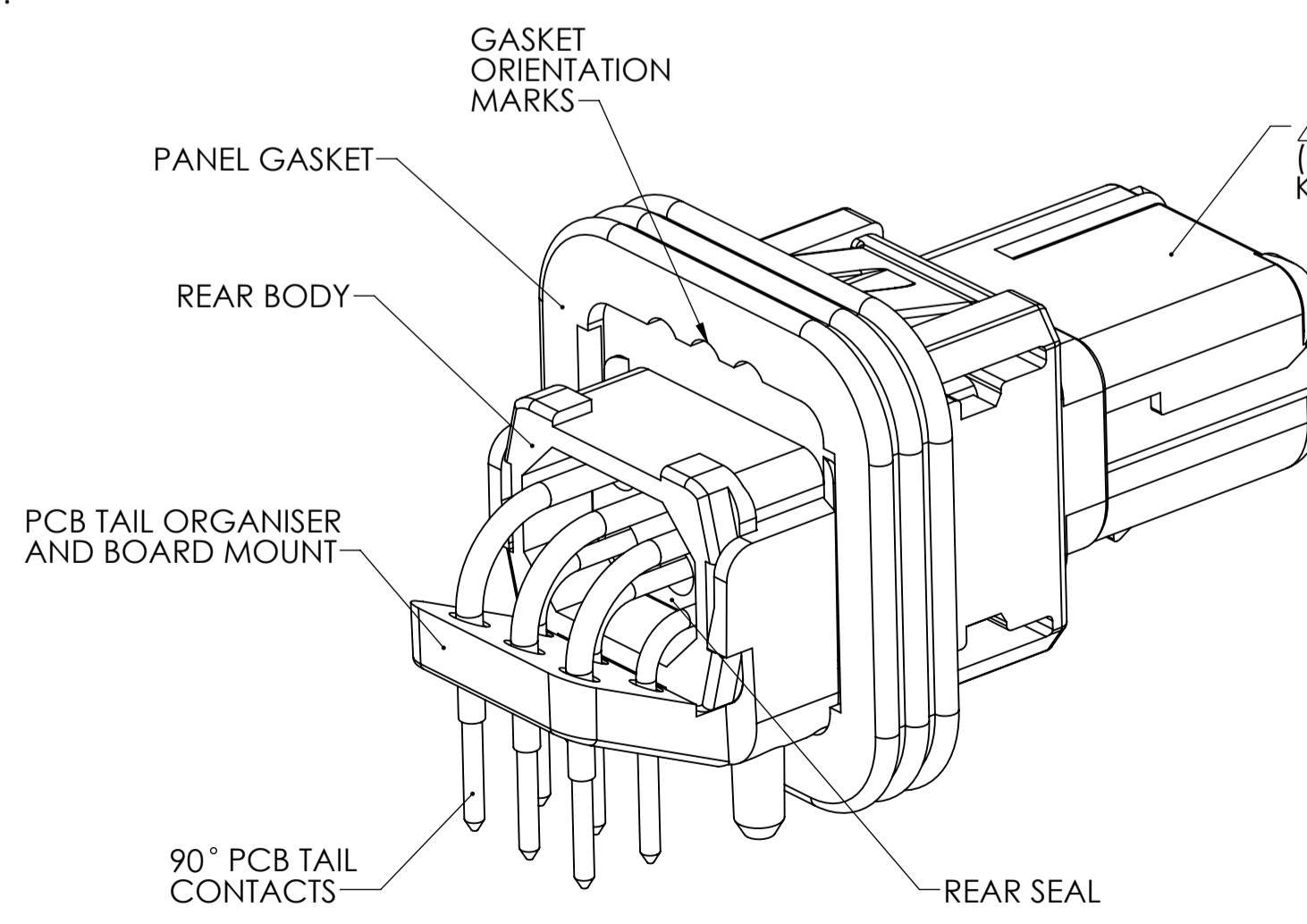
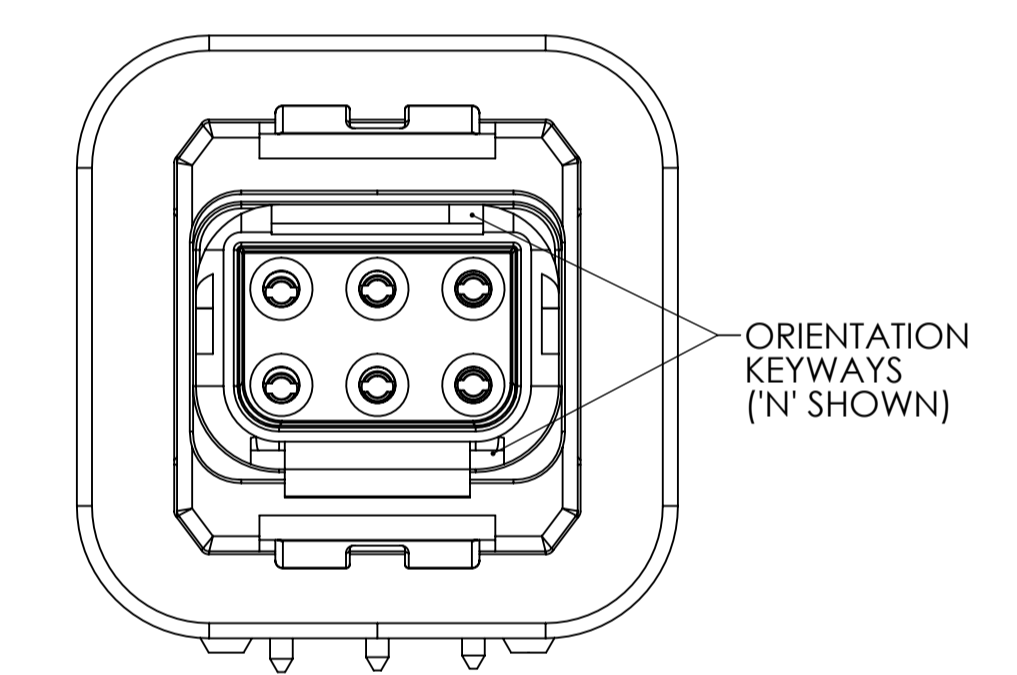
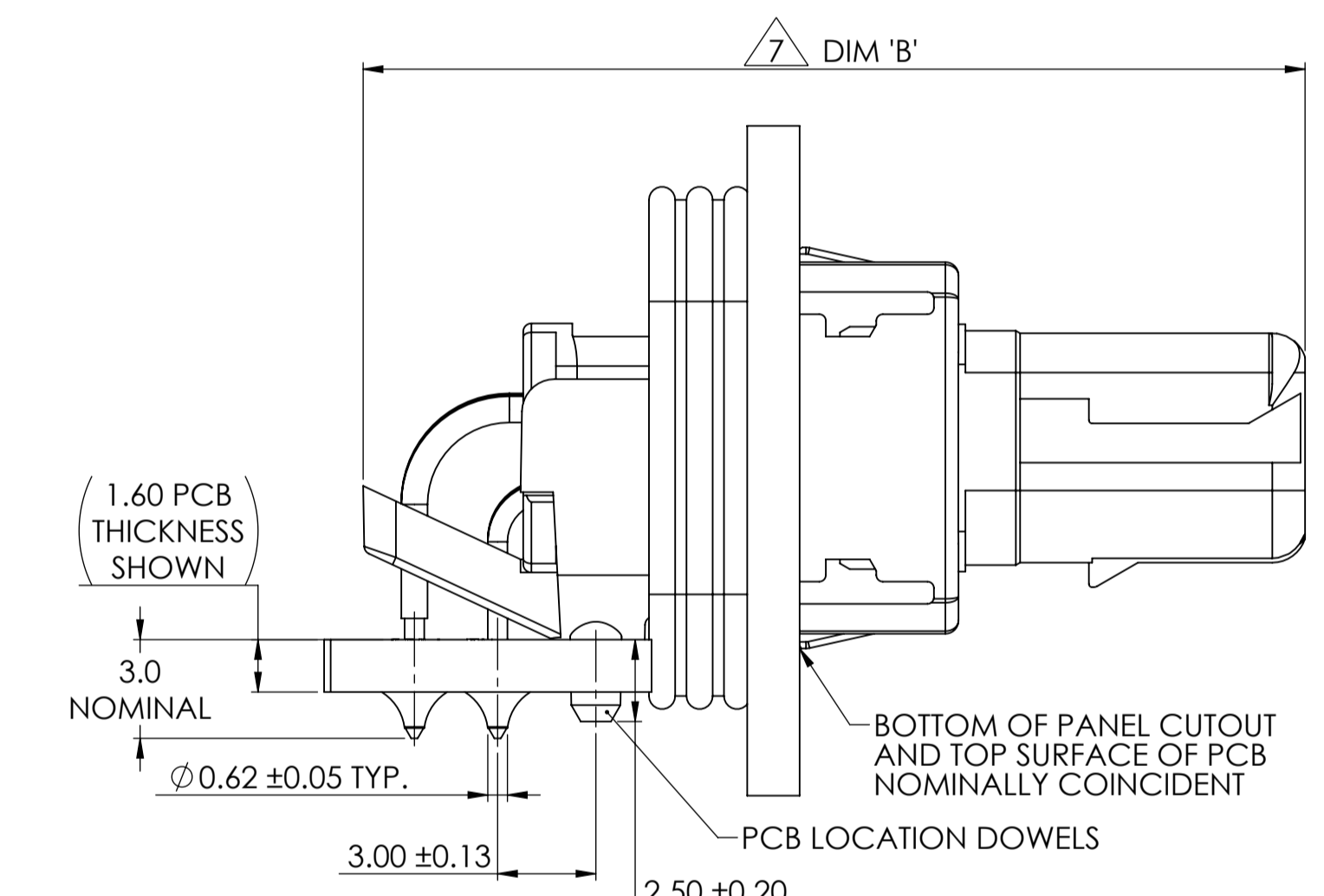
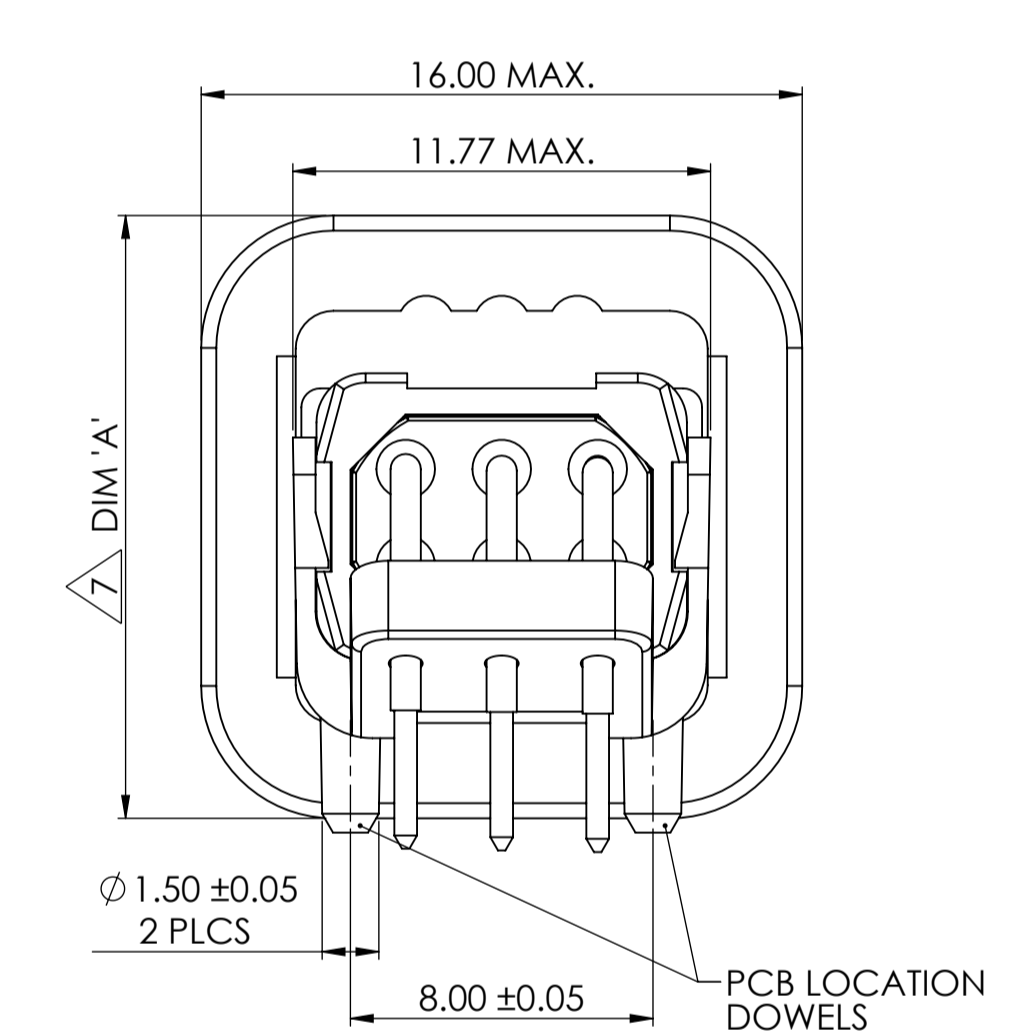
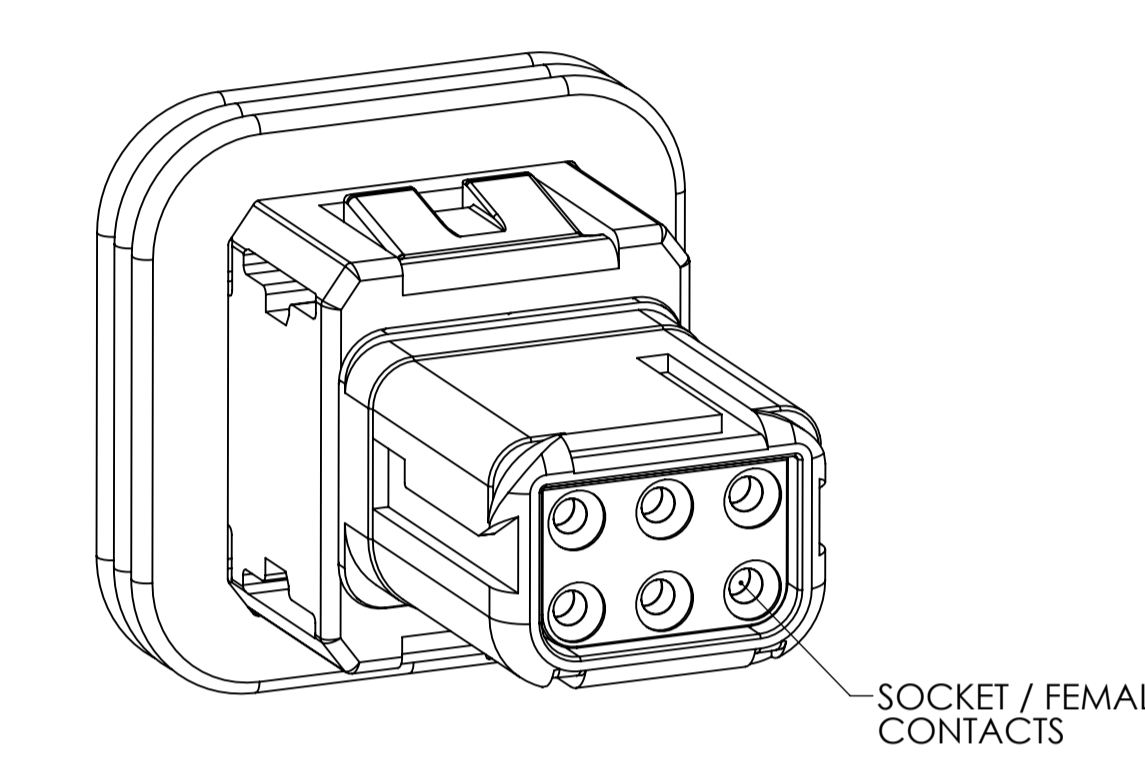
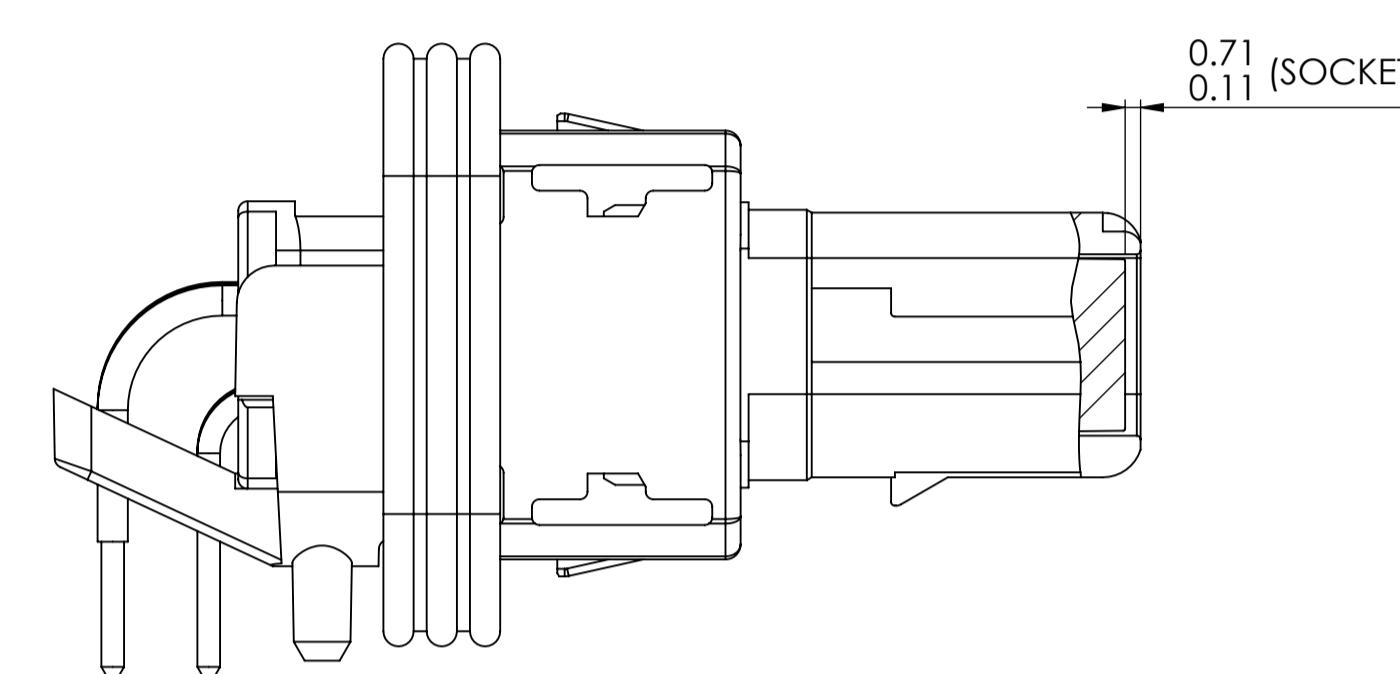
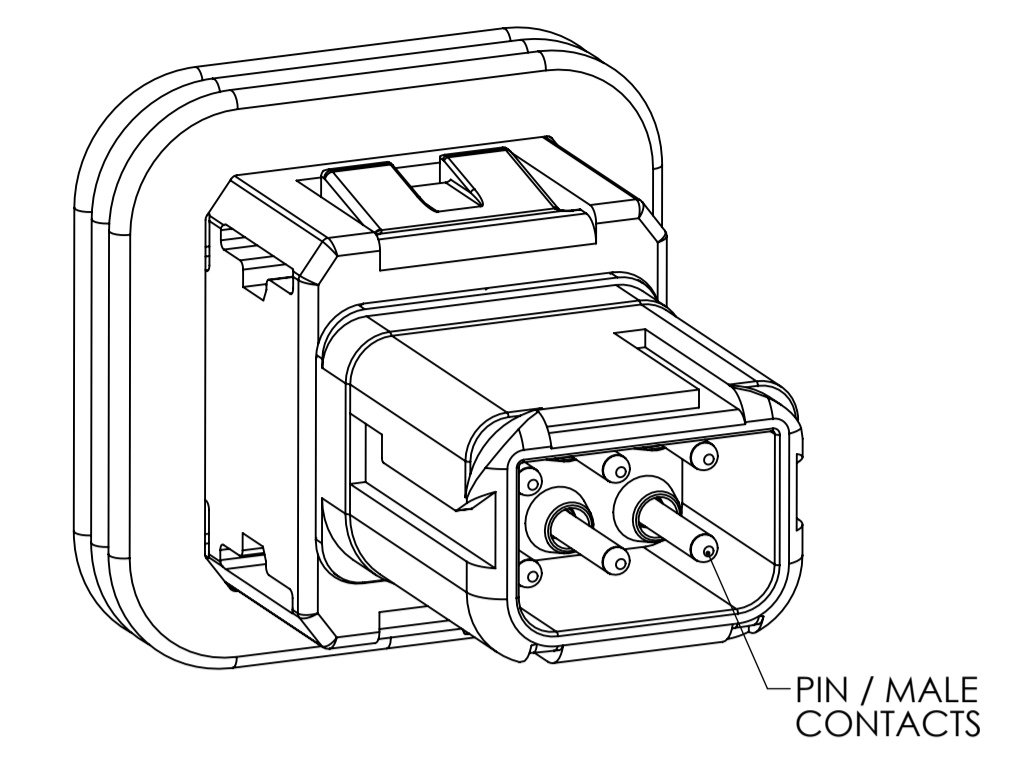
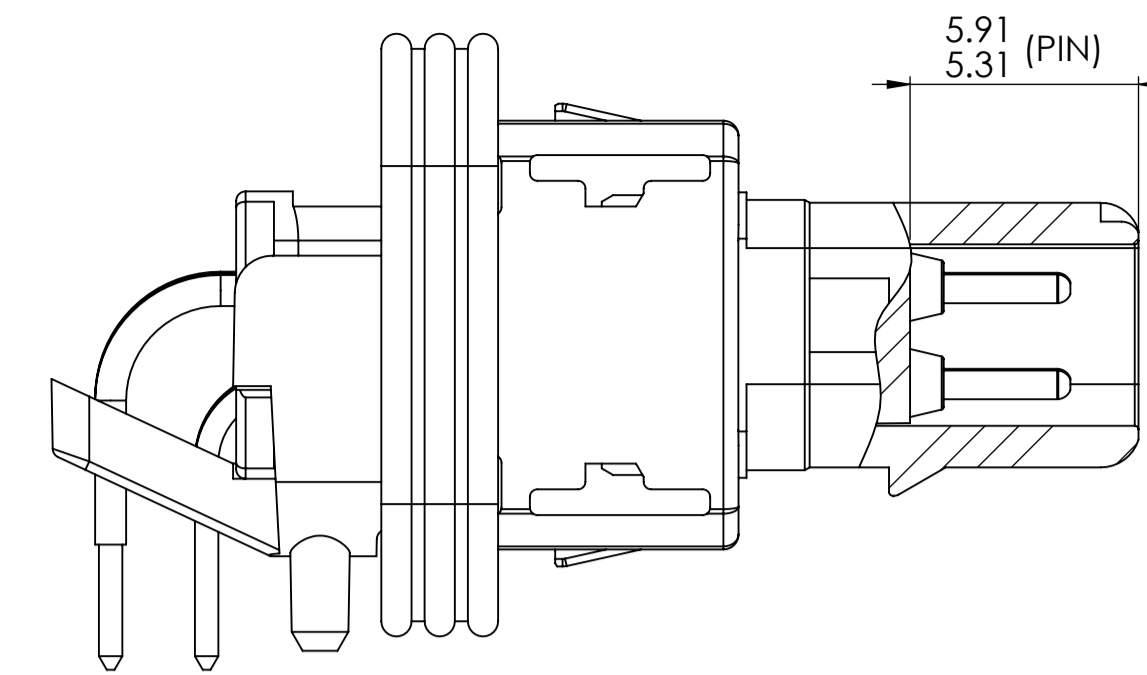

D369-B66-NP4 (PIN) AND D369-B66-NS4 (SOCKET) SHOWN FOR ILLUSTRATIVE PURPOSES

THIS INFORMATION IS CONFIDENTIAL AND PROPRIETARY TO TYCO ELECTRONICS CORPORATION AND ITS WORLDWIDE SUBSIDIARIES AND AFFILIATES (TE). IT MAY NOT BE DISCLOSED TO ANYONE, OTHER THAN TE PERSONNEL, WITHOUT AUTHORIZATION FROM TE (WWW.TECO.TI).

AE	DUK-75579	JOB	JP	NDL	CEO	05/06/2023
ISSUE	CHANGE NOTE	DRAWN	CHECKED	APP. ENG.	APP. MARKETING	DATE

IF IN DOUBT, ASK

BS8888 THIRD ANGLE PROJECTION	MATERIAL: SEE TABLE	FINISH: SEE TABLE	 DEUTSCH TE CONNECTIVITY UK LTD., ST. LEONARDS-ON-SEA, TN38 9RF, UK
UNLESS OTHERWISE STATED: DIMENSIONS: mm [INCHES]	TITLE: D369 PANEL MOUNT PCB RECEPTACLE - 119P MOD TYPE: CUSTOMER DRAWING		
IF IN DOUBT, ASK	SIZE: A1	SCALE: 5:1	DRAWING NUMBER: DENV-119P
			SHEET: 1 OF 3 ISSUE: AE

PCB HOLE LAYOUT DETAIL

3 WAY CONNECTOR

HOLE TYPE	CO-ORDINATES (mm)				HOLE POSITION TOLERANCE	
	PIN		SOCKET			
	X AXIS	Y AXIS	X AXIS	Y AXIS		
PCB LOCATION HOLES	+3.00 REF	+4.00 REF	+3.00 REF	+4.00 REF	∅0.10	
	+3.00 REF	-4.00 REF	+3.00 REF	-4.00 REF		
CONTACT TAIL HOLES	LOCATION	-	-	-	HOLE DIAMETERS AND TOLERANCES AND HOLE POSITION TOLERANCES TO SUIT CUSTOMER PCB DESIGN GUIDELINES	
	1	0	-2.54	0		+2.54
	2	0	0	0		0
	3	0	+2.54	0		-2.54

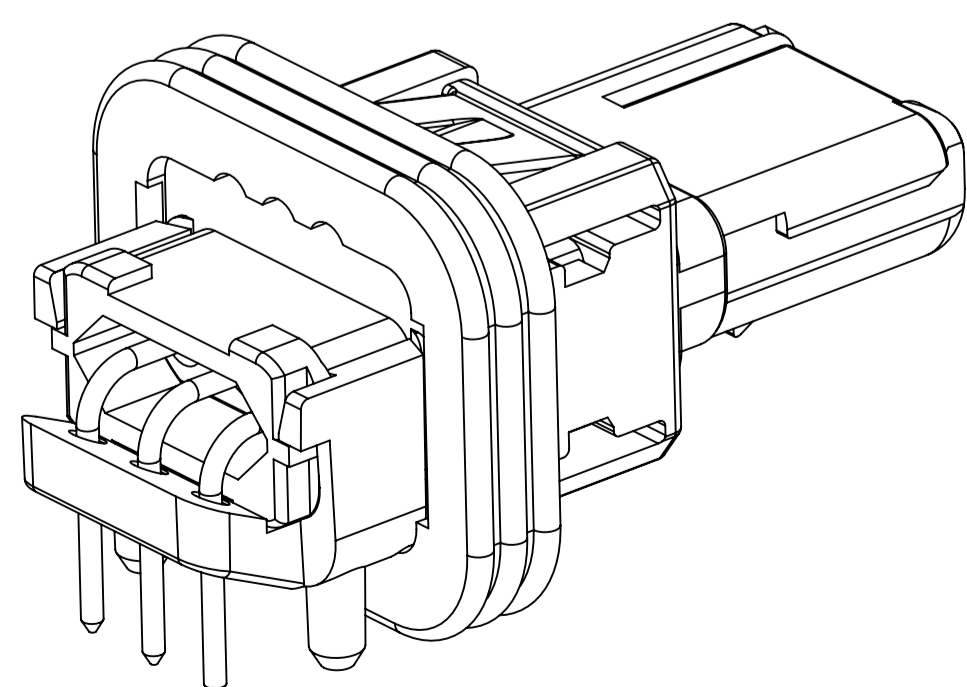
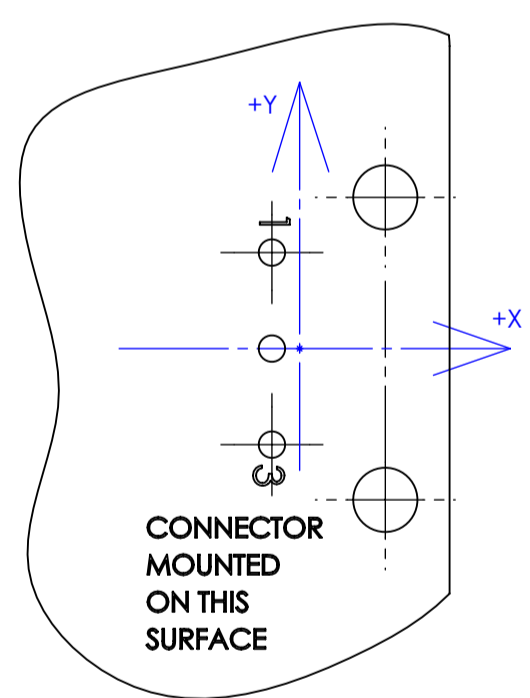
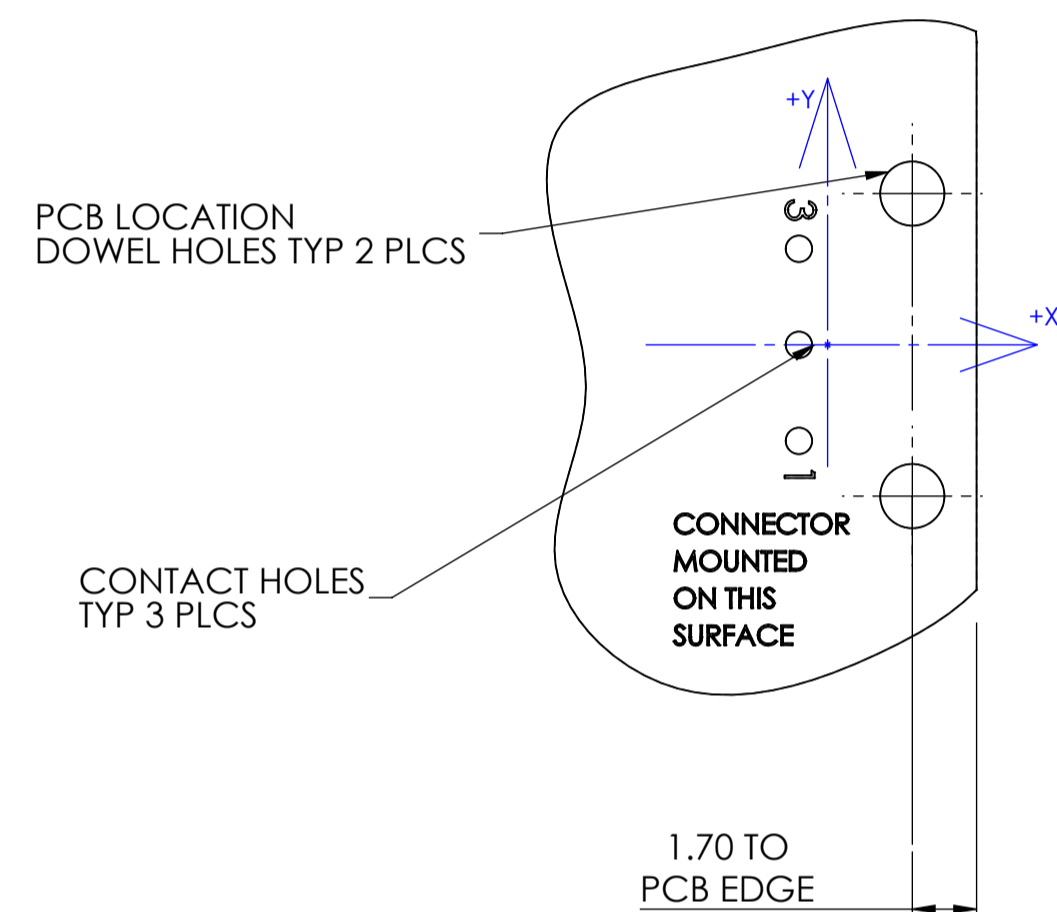

6 WAY CONNECTOR

HOLE TYPE	CO-ORDINATES (mm)				HOLE POSITION TOLERANCE	
	PIN		SOCKET			
	X	Y	X	Y		
PCB LOCATION HOLES	+3.00 REF	+4.00 REF	+3.00 REF	+4.00 REF	∅0.10	
	+3.00 REF	-4.00 REF	+3.00 REF	-4.00 REF		
CONTACT TAIL HOLES	LOCATION	-	-	-	HOLE DIAMETERS AND TOLERANCES AND HOLE POSITION TOLERANCES TO SUIT CUSTOMER PCB DESIGN GUIDELINES	
	1	-2.54	-2.54	-2.54		+2.54
	2	-2.54	0	-2.54		0
	3	-2.54	+2.54	-2.54		-2.54
	4	0	+2.54	0		0
	5	0	0	0		0
	6	0	-2.54	0		+2.54

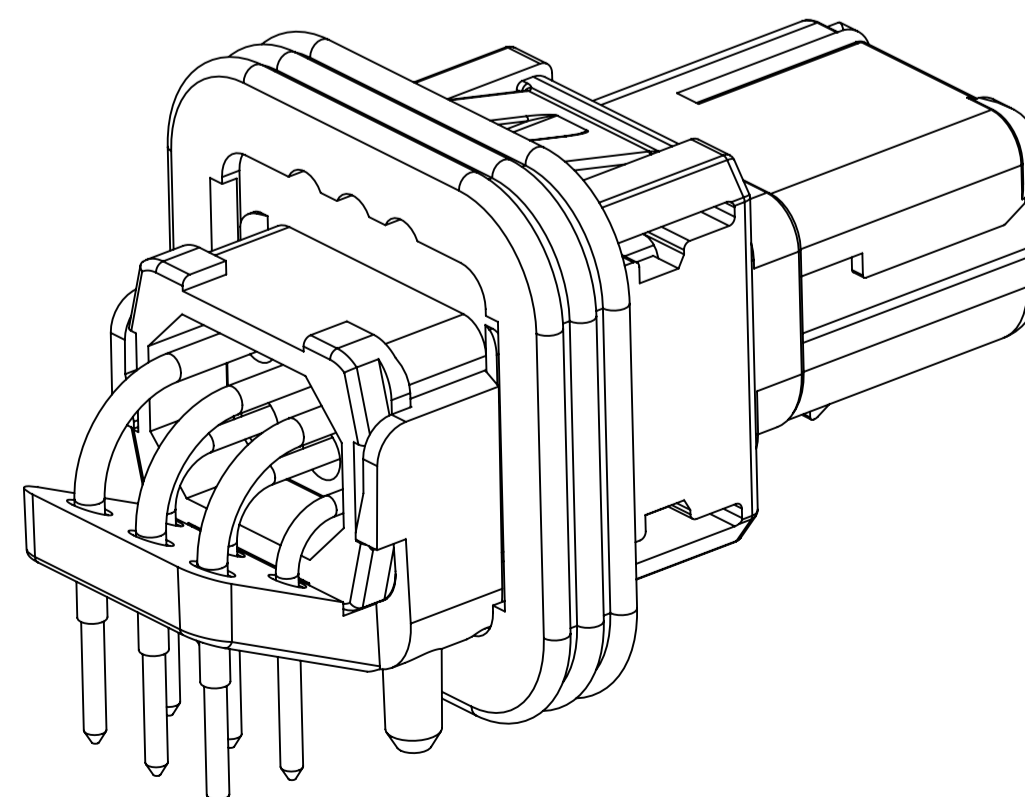
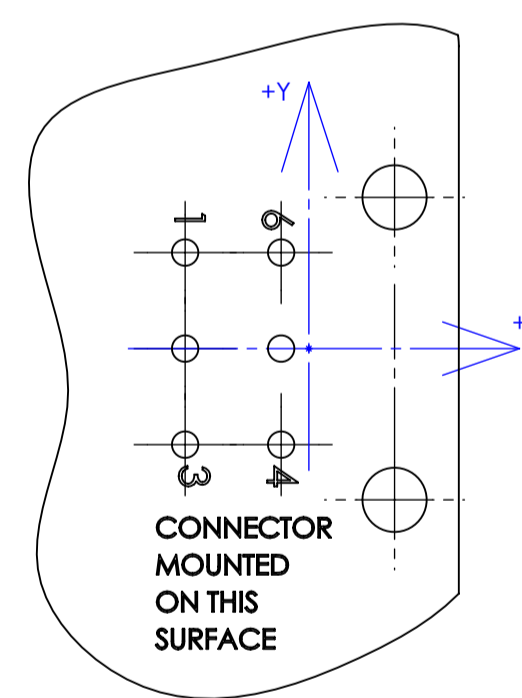
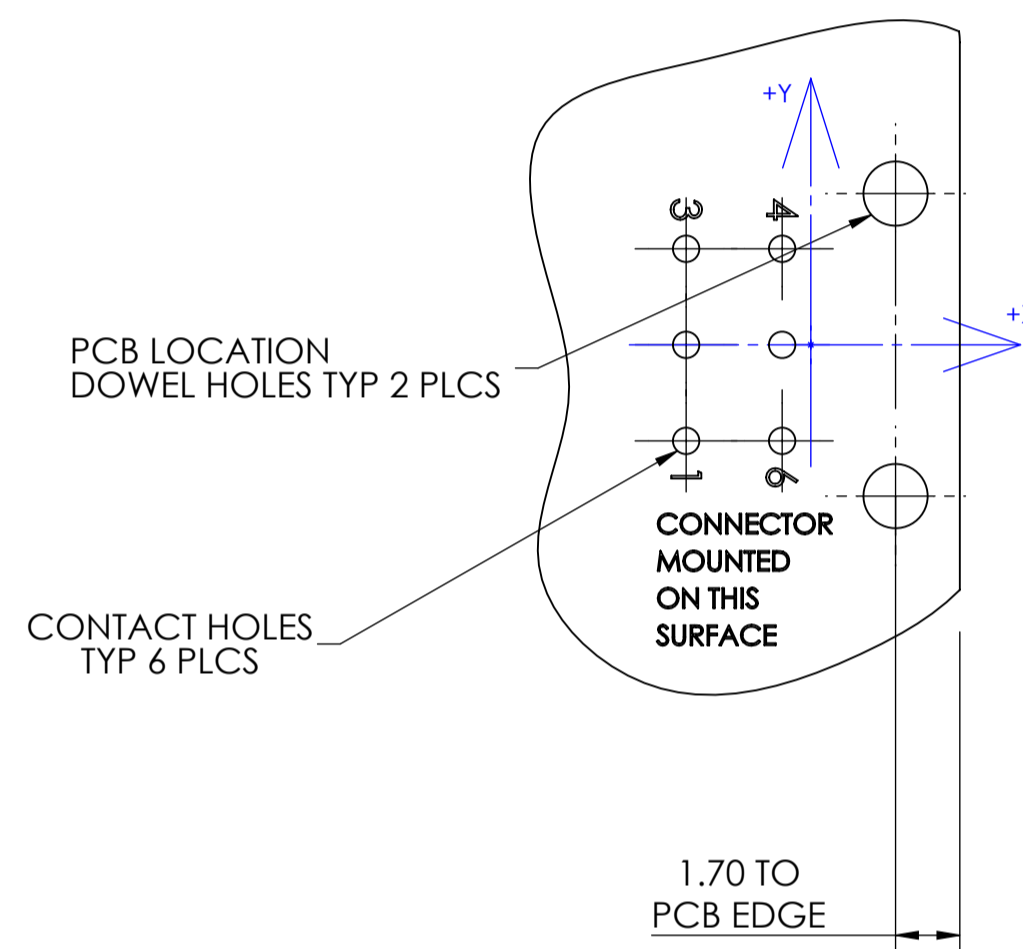

9 WAY CONNECTOR

HOLE TYPE	CO-ORDINATES (mm)				HOLE POSITION TOLERANCE	
	PIN		SOCKET			
	X	Y	X	Y		
PCB LOCATION HOLES	+3.00 REF	+4.00 REF	+3.00 REF	+4.00 REF	∅0.10	
	+3.00 REF	-4.00 REF	+3.00 REF	-4.00 REF		
CONTACT TAIL HOLES	LOCATION	-	-	-	HOLE DIAMETERS AND TOLERANCES AND HOLE POSITION TOLERANCES TO SUIT CUSTOMER PCB DESIGN GUIDELINES	
	1	-5.08	-2.54	-5.08		+2.54
	2	-5.08	0	-5.08		0
	3	-5.08	+2.54	-5.08		-2.54
	4	-2.54	+2.54	-2.54		-2.54
	5	-2.54	0	-2.54		0
	6	-2.54	-2.54	-2.54		+2.54
	7	0	-2.54	0		+2.54
	8	0	0	0		0
	9	0	+2.54	0		-2.54

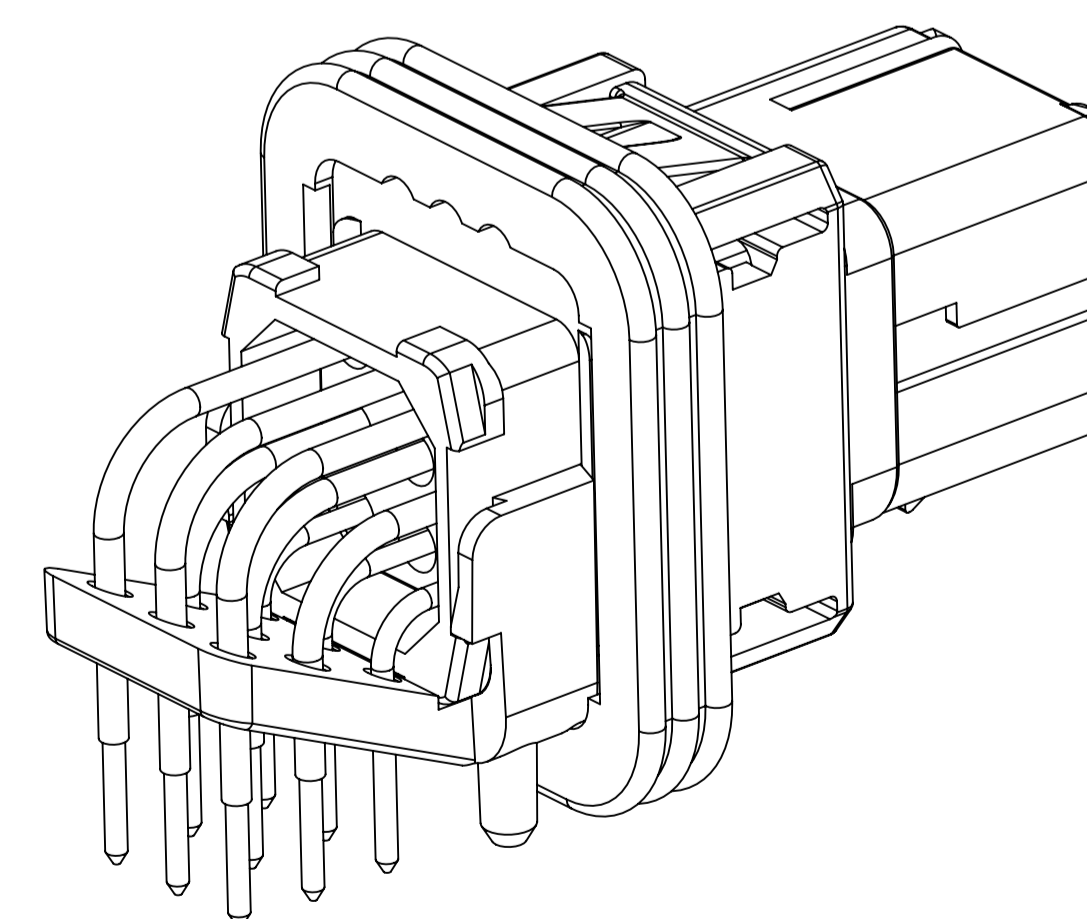
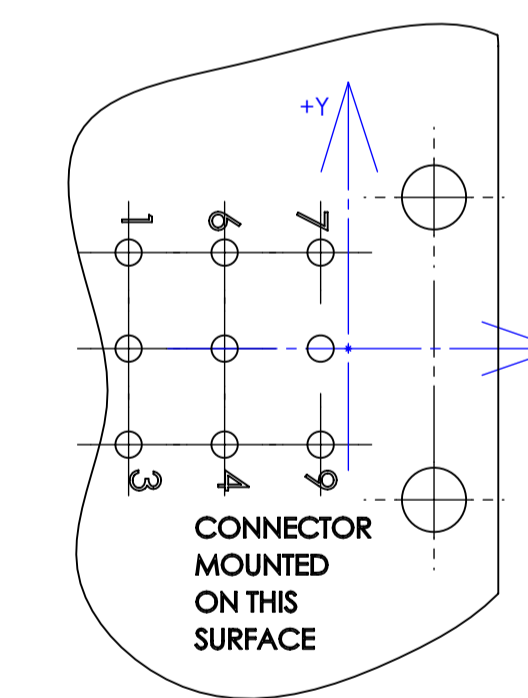
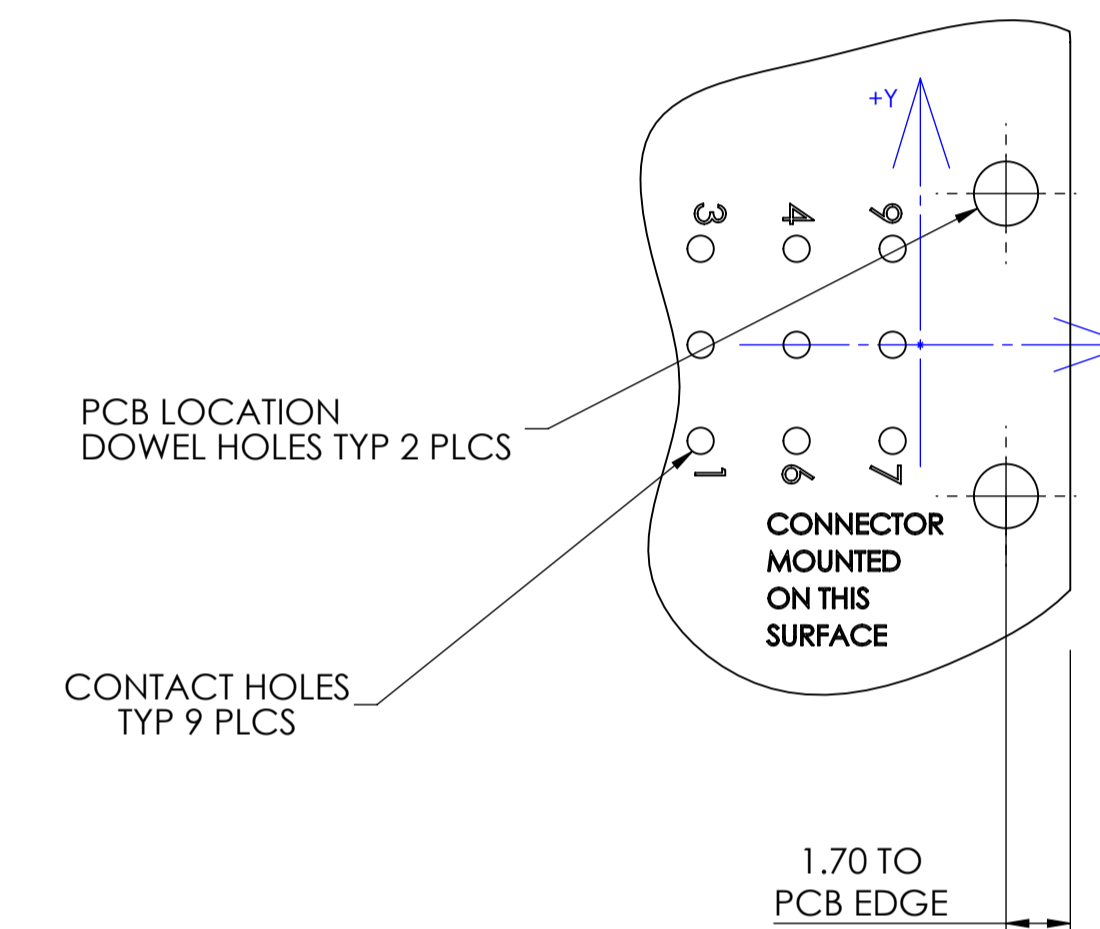

BS8888	MATERIAL: SEE TABLE	FINISH: SEE TABLE	 DEUTSCH
THIRD ANGLE PROJECTION	TYPE: CUSTOMER DRAWING		
UNLESS OTHERWISE STATED: DIMENSIONS: mm [INCHES]	TITLE: D369 PANEL MOUNT PCB RECEPTACLE - 119P MOD		
IF IN DOUBT, ASK	SIZE: A1	SCALE: 5:1	DRAWING NUMBER: DENV-119P
			SHEET: 2 OF 3
			ISSUE: AE

THIS INFORMATION IS CONFIDENTIAL AND PROPRIETARY TO TYCO ELECTRONICS CORPORATION AND ITS WORLDWIDE SUBSIDIARIES AND AFFILIATES (TE). IT MAY NOT BE DISCLOSED TO ANYONE, OTHER THAN TE PERSONNEL, WITHOUT AUTHORIZATION FROM TE (www.teccotti).

INLINE CONNECTOR, CRIMP CONTACTS VARIANT

NOTES

9 INSERTION/EXTRACTION TOOL (M81969/14-01 OR EQUIVALENT) SUPPLIED SEPARATELY

CONTACT CONFIGURATION	CONTACT DESCRIPTION	CONTACT P/N (OR EQUIVALENT)		CRIMP POSITIONER		CRIMP TOOL	WIRE ACCOMODATION	CURRENT RATING
		PIN	SOCKET	PIN	SOCKET			
0		NO CONTACTS SUPPLIED						
1	CRIMP, COPPER WIRE	38941-22	38946-22	M22520/2-09	M22520/2-06	M22520/2-01	22-28 AWG	5A (22 AWG)
2	CRIMP, ALUMINIUM WIRE	200-1042-22	200-1142-22	KAL 2		ALNP 22-A	22 AWG	5A
3	CRIMP, COPPER WIRE (ENLARGED WIRE)	182-0860-22	182-0862-22	M22520/2-09	M22520/2-06	M22520/2-01	20-24 AWG	5A (20 AWG)

D369-B66-NP0 (PIN) AND D369-B66-NS0 (SOCKET) SHOWN FOR ILLUSTRATIVE PURPOSES

10 DIMENSIONS:

SHELL SIZE	DIM MAX.
3	5.36
6	7.90
9	10.44

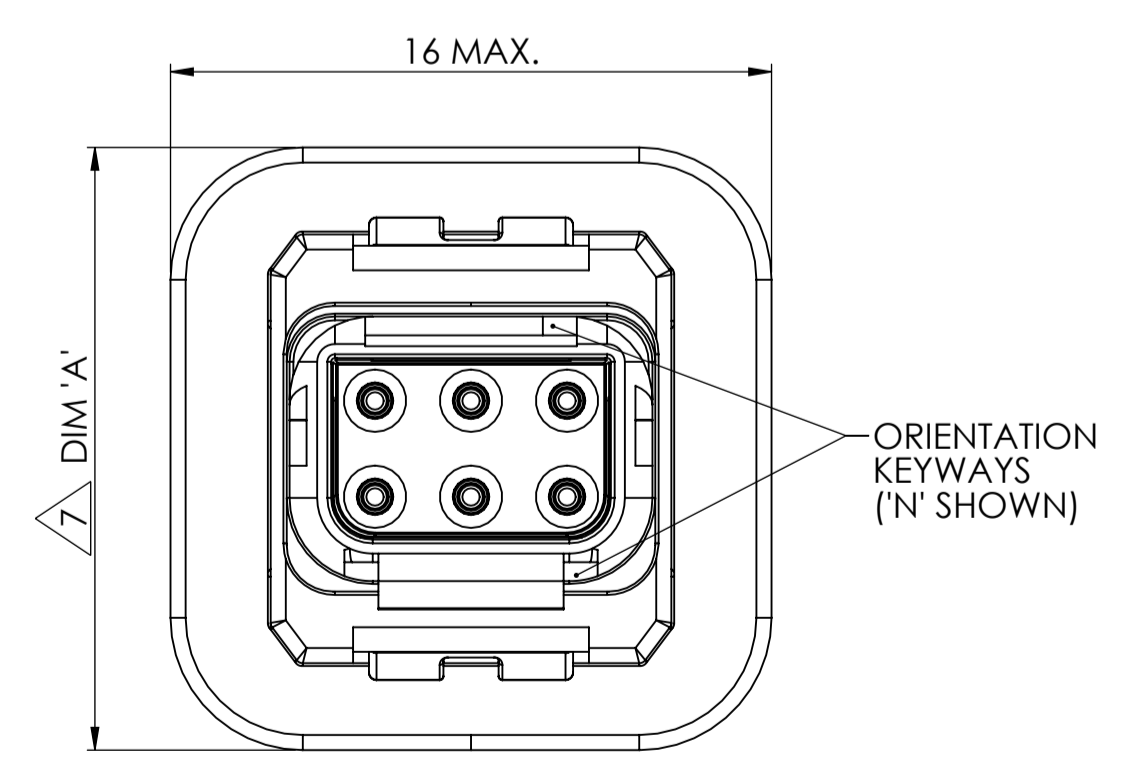
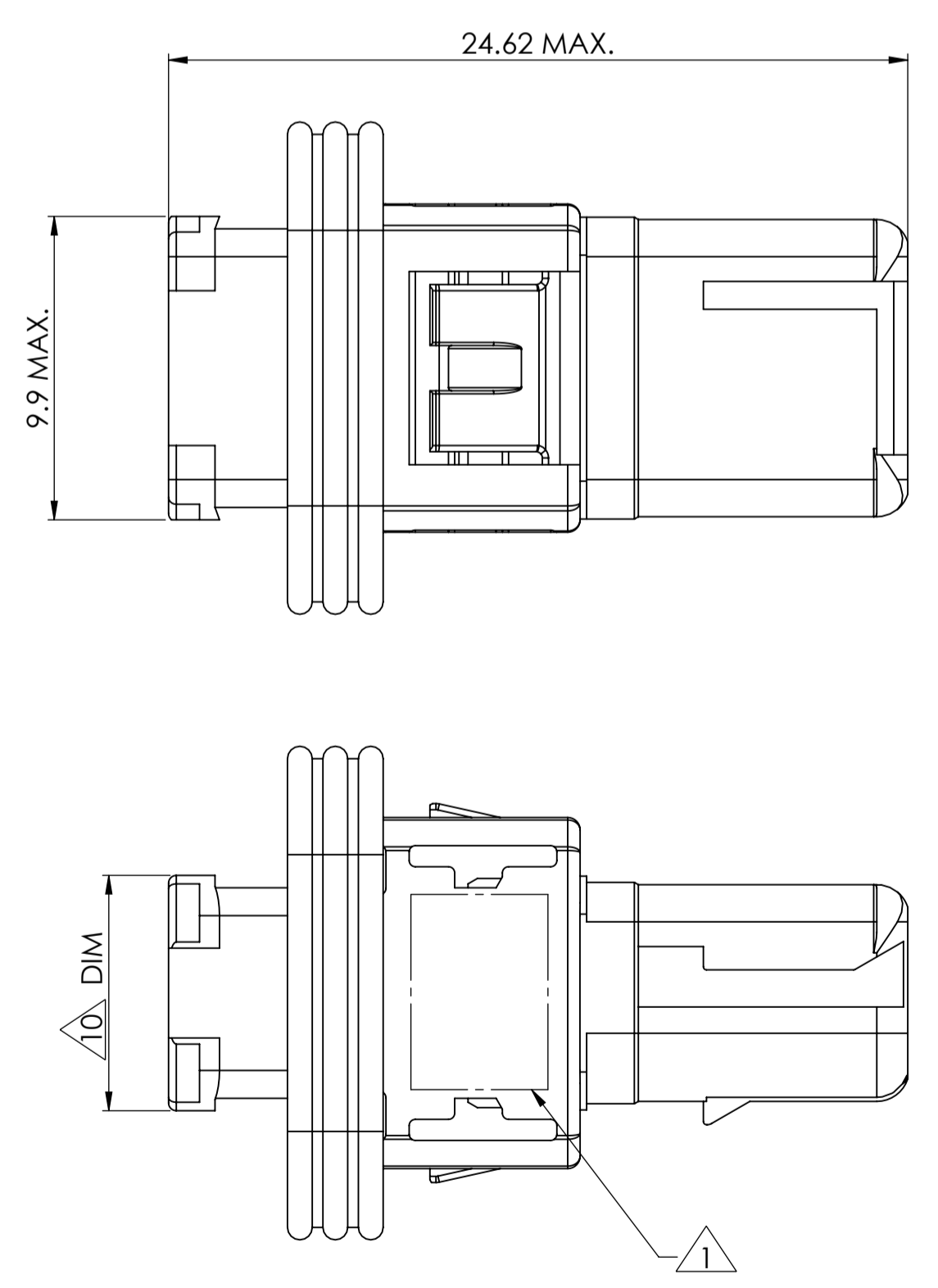
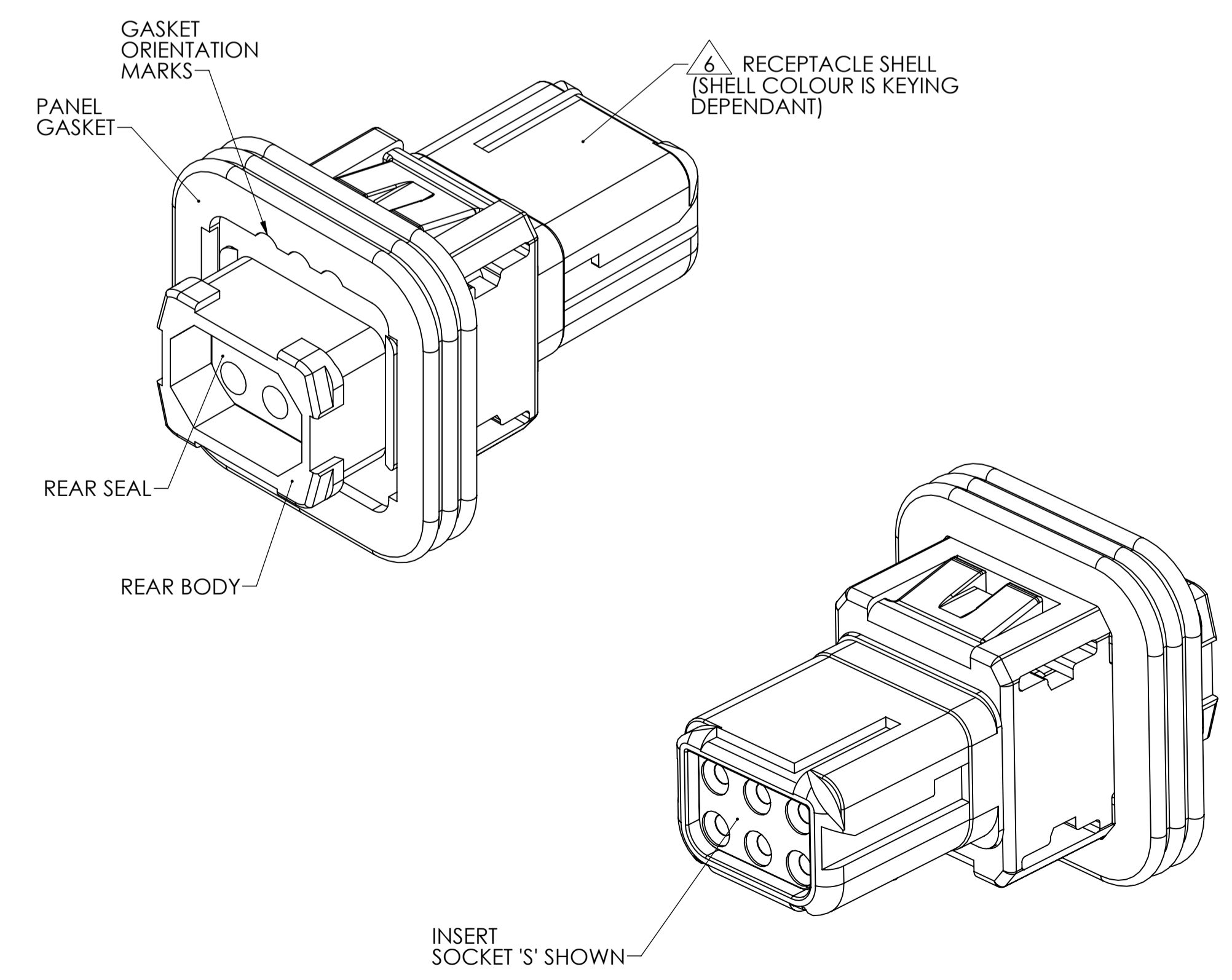
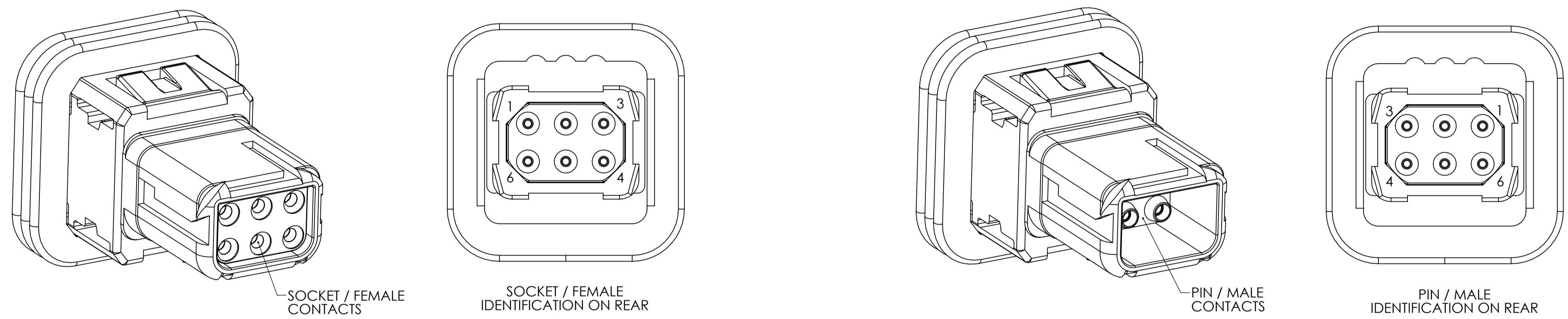

IF IN DOUBT, ASK

BS8888 THIRD ANGLE PROJECTION	MATERIAL: SEE TABLE	FINISH: SEE TABLE	 DEUTSCH TE CONNECTIVITY UK LTD. ST. LEONARDS-ON-SEA, TN38 9RF, UK
UNLESS OTHERWISE STATED: DIMENSIONS: mm [INCHES]	TITLE: D369 PANEL MOUNT PCB RECEPTACLE - 119P MOD		
IF IN DOUBT, ASK	SIZE: A1	SCALE: 5:1	DRAWING NUMBER: DENV-119P
			SHEET: 3 OF 3
			ISSUE: AE

THIS INFORMATION IS CONFIDENTIAL AND PROPRIETARY TO TYCO ELECTRONICS CORPORATION AND ITS WORLDWIDE SUBSIDIARIES AND AFFILIATES (TE). IT MAY NOT BE DISCLOSED TO ANYONE, OTHER THAN TE PERSONNEL, WITHOUT AUTHORIZATION FROM TE (www.teccotti).