

7 6 5 4 3 2 1

REV H DRC23-80P

REVISIONS			
SYM	DESCRIPTION	DATE	APPROVED
E	REDRAWN & REVISED PER E.O. P16859	12-28-00	R.D.R.
F	REVISED PER E.O. P17100	1-23-01	R.D.R.
G	REVISED PER E.O. P18740	11-12-04	R.D.R.
H	REVISED PER E.O. P21465	9/19/12	DW

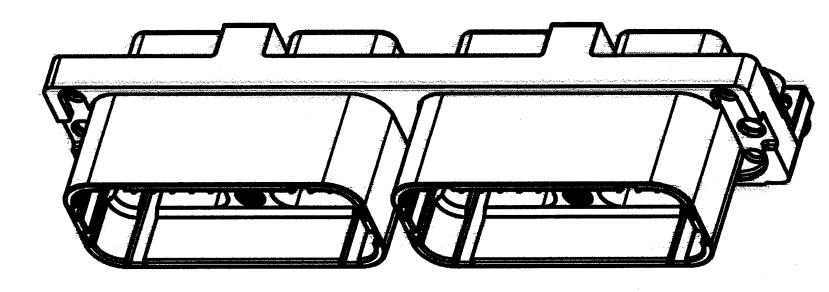
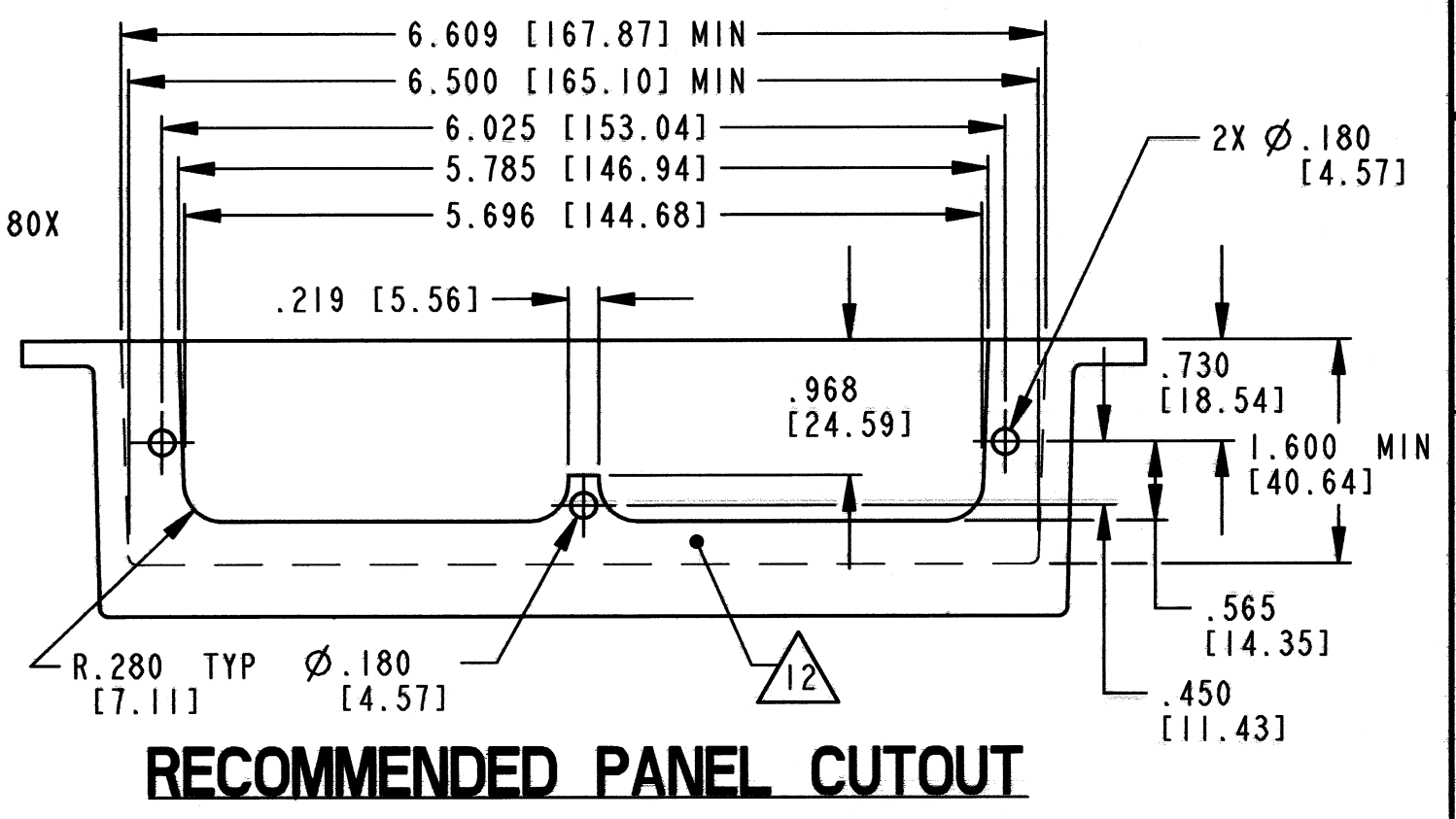
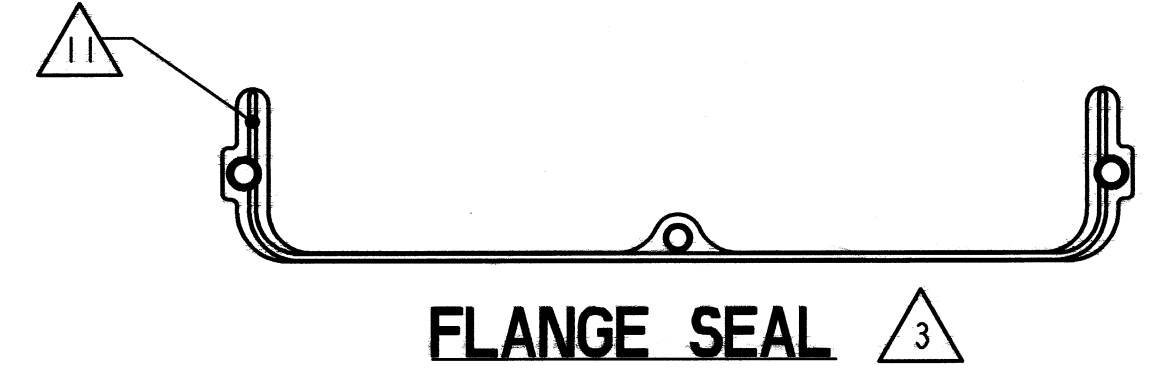
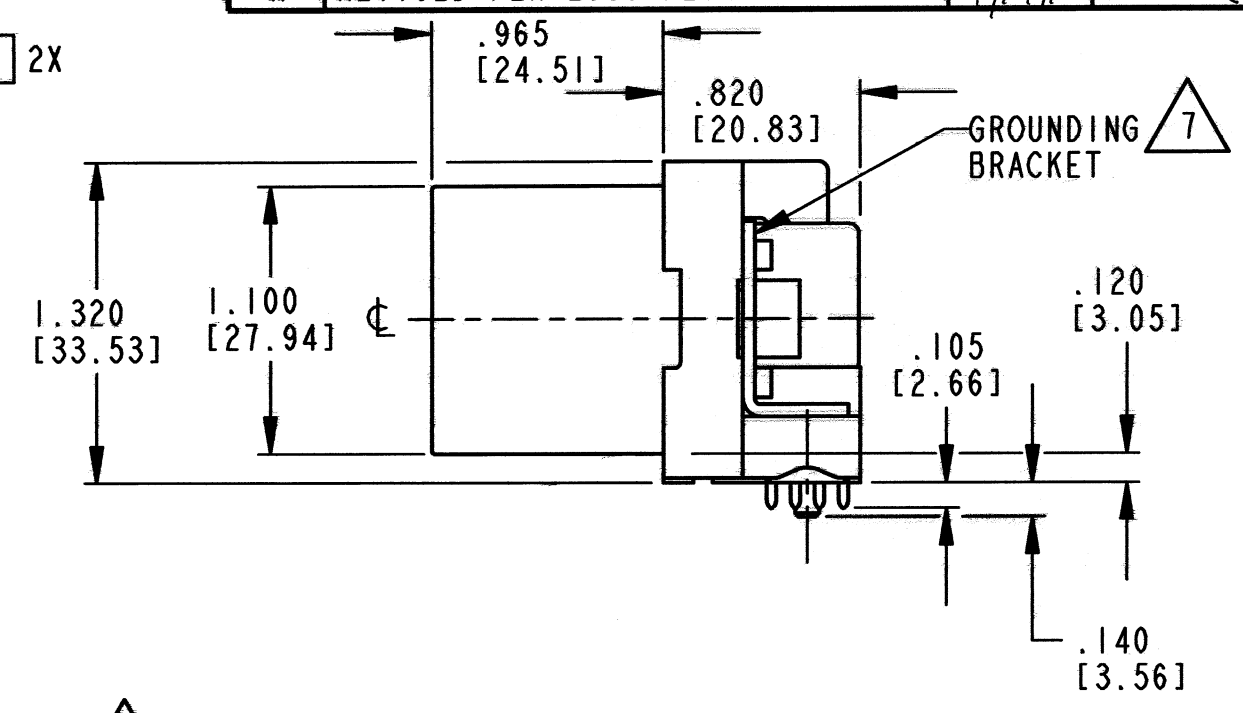
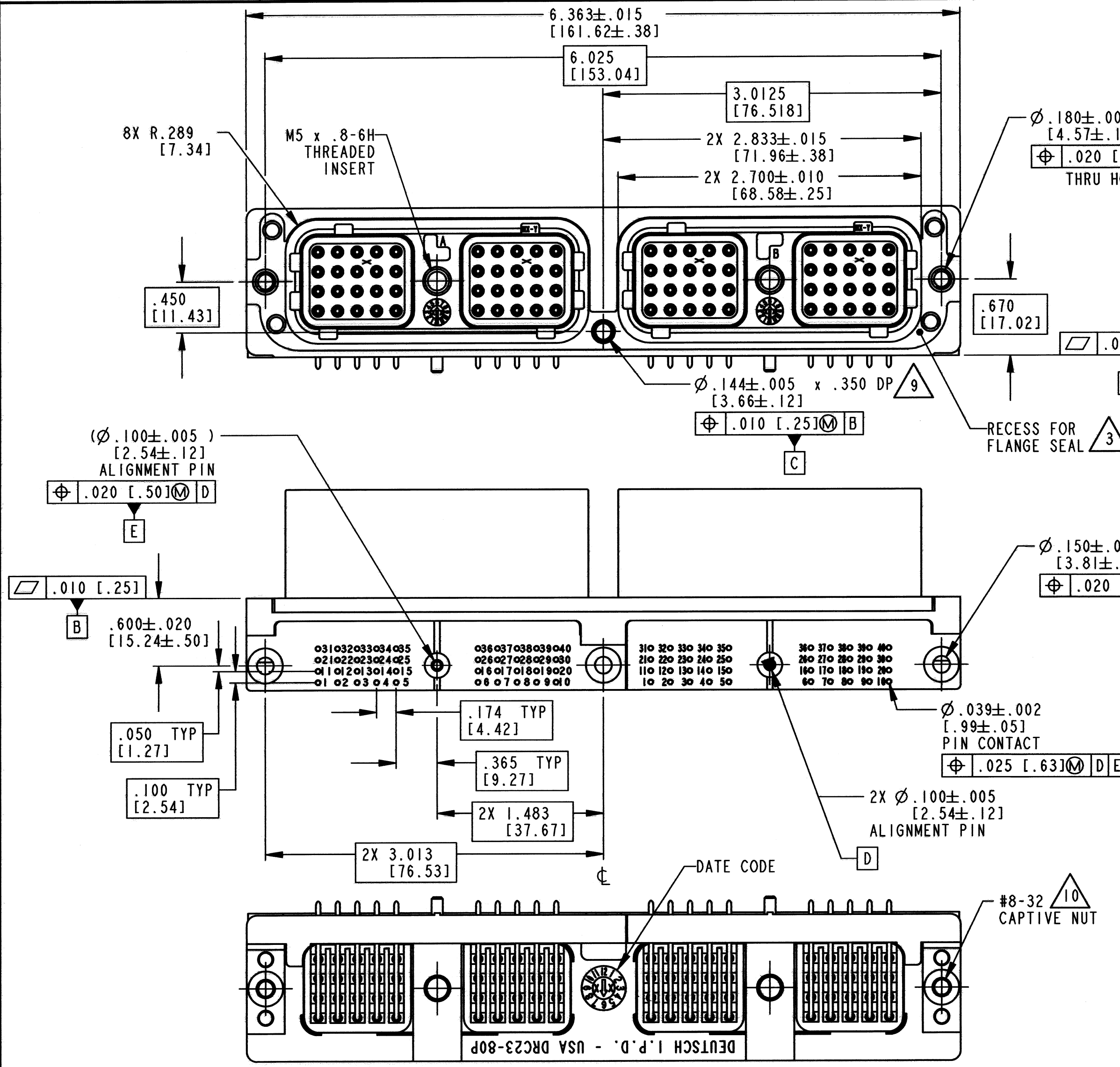

- 8. THIS RECEPTACLE MATES WITH DRC26-40SA-\*\*\*\* AND DRC26-40SB-\*\*\*\* PLUG (\*\*\*\*=ALL MODIFICATIONS).
- 7. GROUNDING BRACKET PLATING: NICKEL.
- 6. CONTACT PLATING - MATING SIDE: GOLD; PCB SIDE: TIN.
- 5. MATERIAL - PLASTIC (BLACK); INSERT: STEEL; GROUNDING BRACKET: COPPER; CAPTIVE NUT: BRASS; SEALS: RUBBER.
- 4. RECEPTACLE IS SUPPLIED WITH 2 DUST CAPS (NOT SHOWN).
- 3. FLANGE SEAL (P/N 0513-017-8006) IS SOLD SEPARATELY.
- 2. DIMENSION TOLERANCE: ±.025 [0.64]; PANEL CUTOUT: ±.010 [0.25].
- 1. DIMENSIONS ARE IN INCHES [mm].

- 12. SURFACE FINISH: 32 RMS OR BETTER; .005 [0.12].
- 11. FULLY SEAT THE FLANGE SEAL IN THE RECESS WITH THE RAISED SEAL FACING OUTWARD.
- 10. RECOMMENDED SCREW: 8-32 MACHINE SCREW. TORQUE: 15-20 IN-LB [1.69-2.26 NM].
- 9. RECOMMENDED SCREW: 7-18 [M4.06 x 1.41] THREAD-FORMING SCREW. TORQUE: 10-15 IN-LB [1.13-1.69 NM].

NOTES: UNLESS OTHERWISE SPECIFIED

SIGNATURE & DATE	
DR	J. APOSTOL 26SEP2000
CHK	[Signature] 9/19/12
PE	[Signature] 9/19/12
APPD	[Signature] 9/19/12
SCALE	NONE
WT	

RECEPTACLE  
80 #20 SIZE CONTACTS  
KEY ARRANGEMENTS  
-A- & -B-  
DRC SERIES  
ENVELOPE

EP	MATL. CODE
3850 INDUSTRIAL AVE. HEMET, CA 92545	
DEUTSCH INDUSTRIAL	
C DRC23-80P	
DWG SIZE	CODE 11139
SHEET 1 OF 1	

7 6 5 4 3 2 1