

LEFT SECTION

REVISIONS					
P	LTR	DESCRIPTION	DATE	DWN	APVD
A		INITIAL RELEASE	14APR2020	SL	LH
B		TYPO CORRECTION	23NOV2022	HM	LH
C		FASTENERS CHANGED TO SS MATERIAL	28FEB2025	BJ	LH

TCPN	DESCRIPTION
EN7339-000	WLG-60(B1)

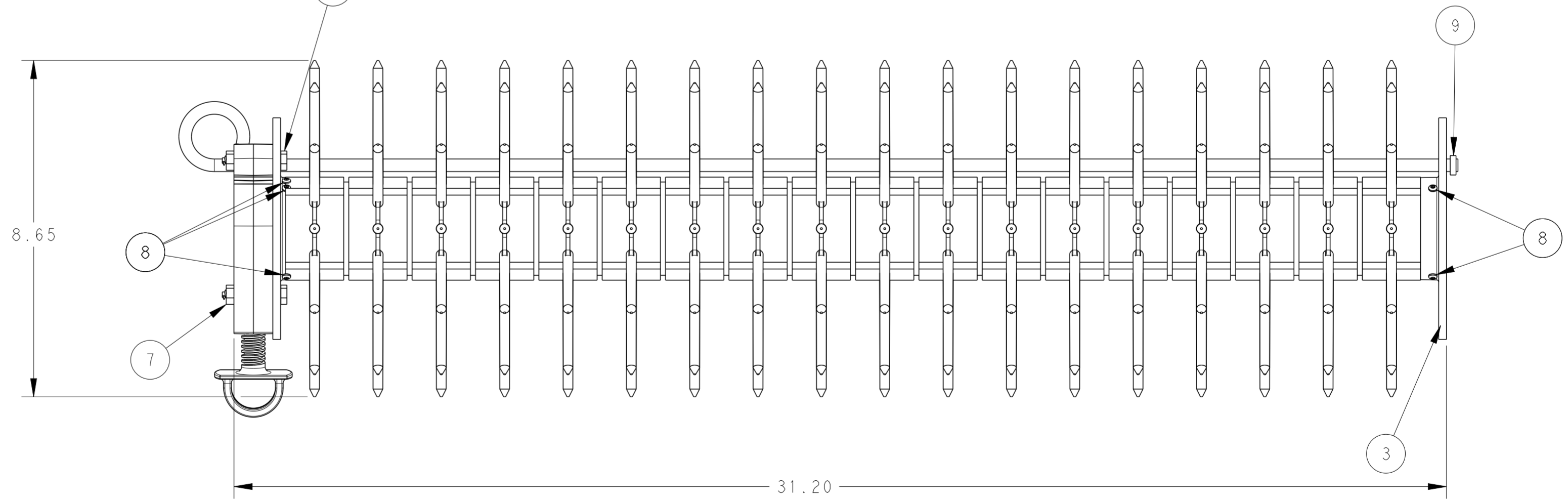
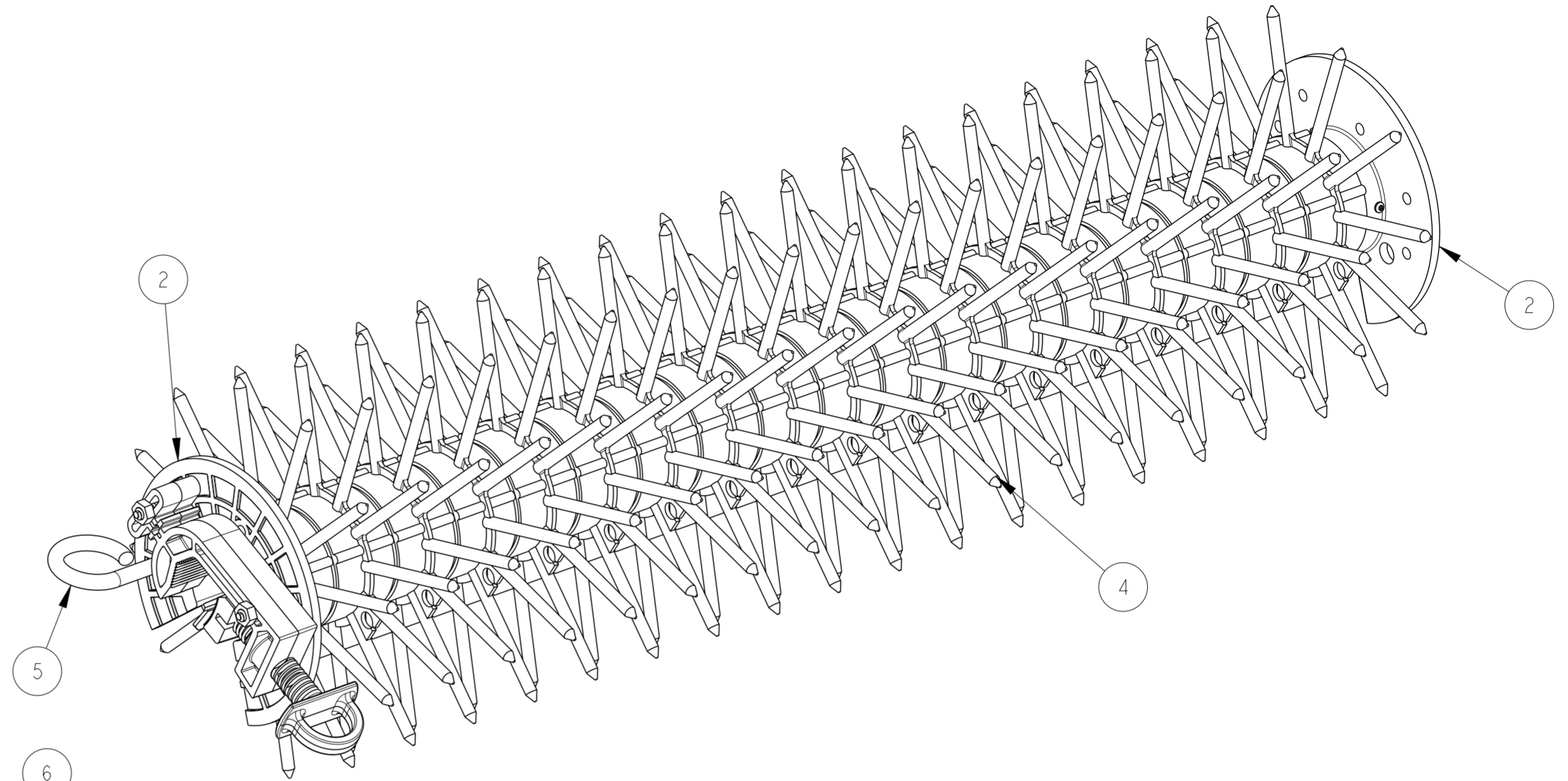
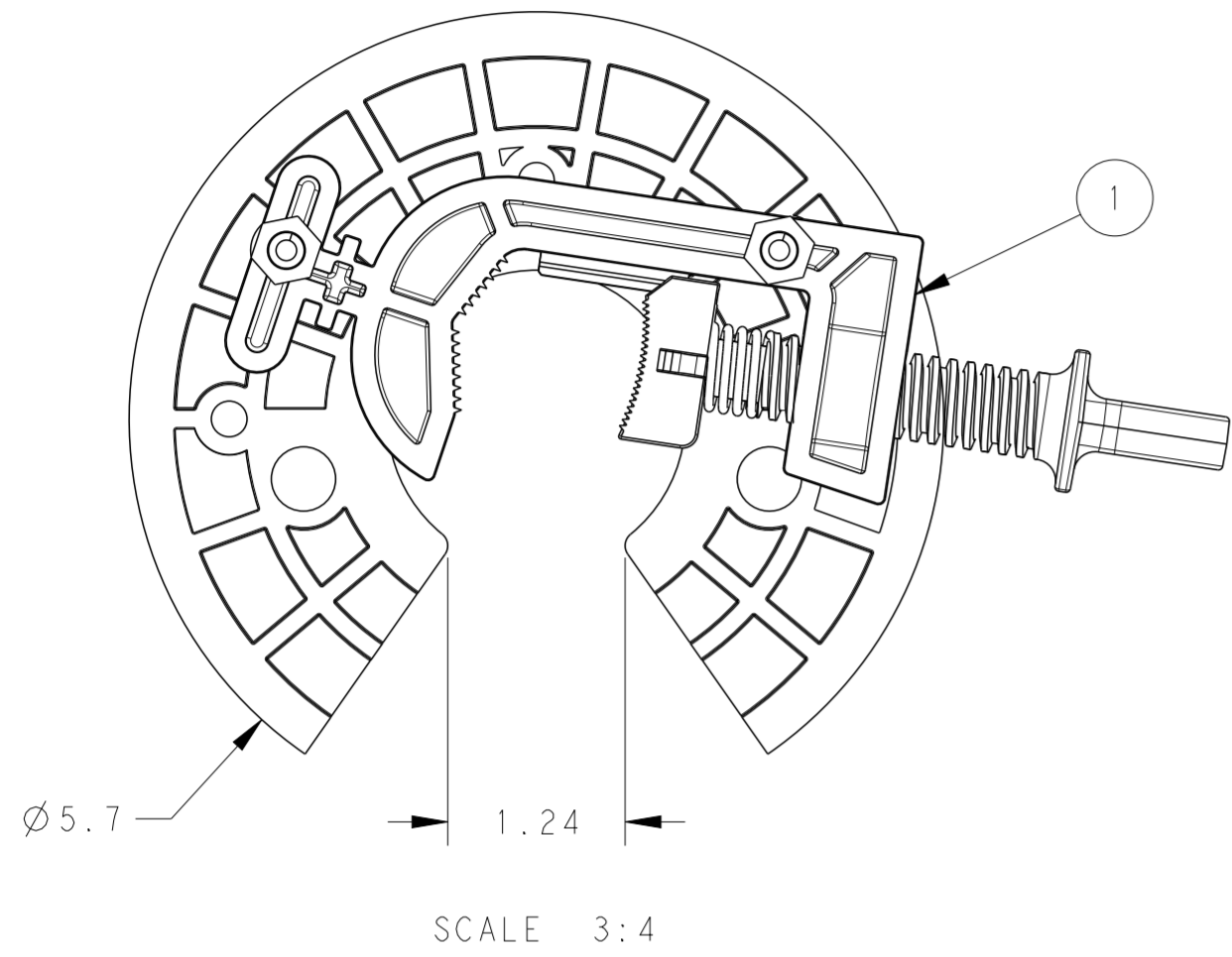

ITEM	DESCRIPTION	QTY
1	WLG-CLAMP	1
2	WLG-ENDPLATE	2
3	WLG-TUBE	1
4	WLG-STAR	18
5	WLG-ROD	1
6	SS BOLT	2
7	SS NUT	2
8	SS SCREWS	8
9	WASHER	1

THIS DRAWING IS A CONTROLLED DOCUMENT.		DWN	14APR2020	STE TE Connectivity													
DIMENSIONS: in		CHK	14APR2020														
TOLERANCES UNLESS OTHERWISE SPECIFIED:		APVD	14APR2020														
<table border="1"> <tr><td>0 PLC</td><td>±.01</td></tr> <tr><td>1 PLC</td><td>±.02</td></tr> <tr><td>2 PLC</td><td>±.03</td></tr> <tr><td>3 PLC</td><td>±.005</td></tr> <tr><td>4 PLC</td><td>±.0005</td></tr> <tr><td>ANGLES</td><td>±</td></tr> <tr><td>FINISH</td><td></td></tr> </table>		0 PLC	±.01		1 PLC	±.02	2 PLC	±.03	3 PLC	±.005	4 PLC	±.0005	ANGLES	±	FINISH		PRODUCT SPEC
0 PLC	±.01																
1 PLC	±.02																
2 PLC	±.03																
3 PLC	±.005																
4 PLC	±.0005																
ANGLES	±																
FINISH																	
MATERIAL		APPLICATION SPEC	-	NAME	WLG-60 ASSEMBLY												
		WEIGHT	-	SIZE	A200779												
		CUSTOMER DRAWING		CAGE CODE	C-E00000740												
		SCALE	2:5	DRAWING NO													
		SHEET	1 OF 2	RESTRICTED TO	-												
		REV	C														

P	LTR	DESCRIPTION	DATE	DWN	APVD
-		SEE SHEET 1	-	-	-

RIGHT SECTION

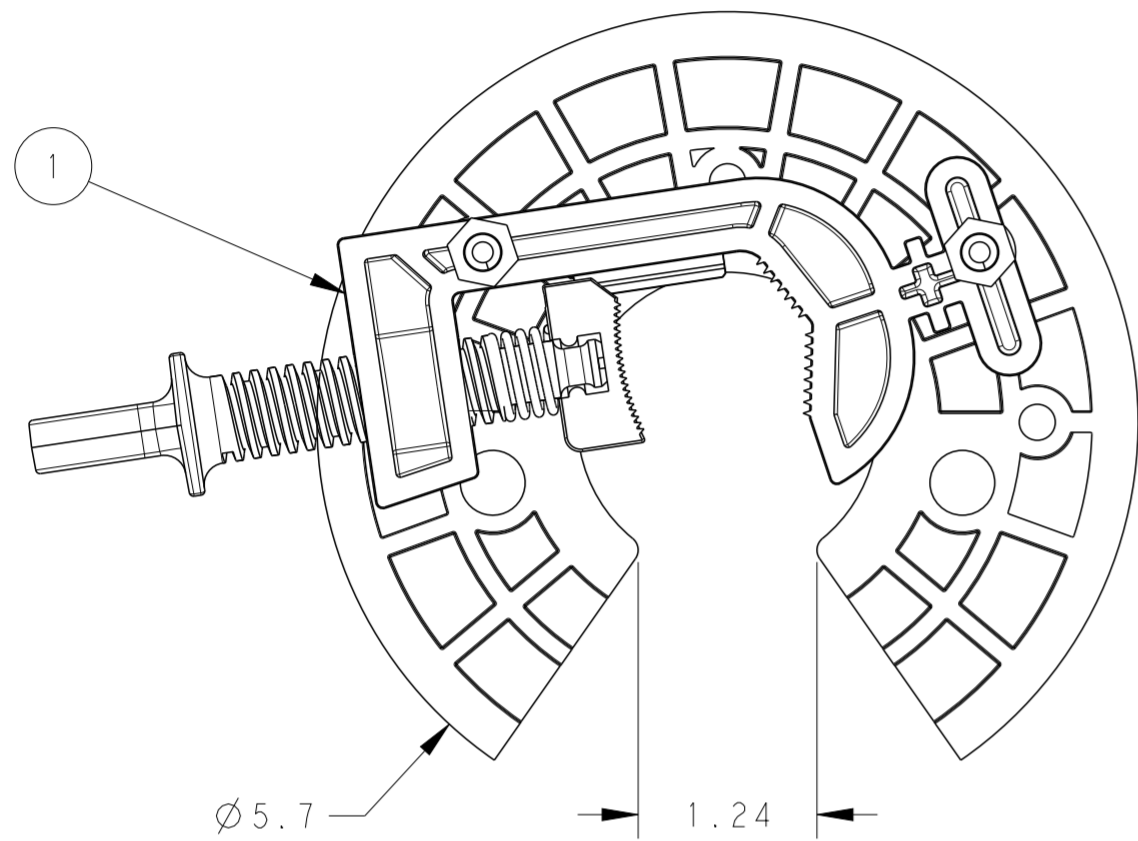

SCALE 3:4

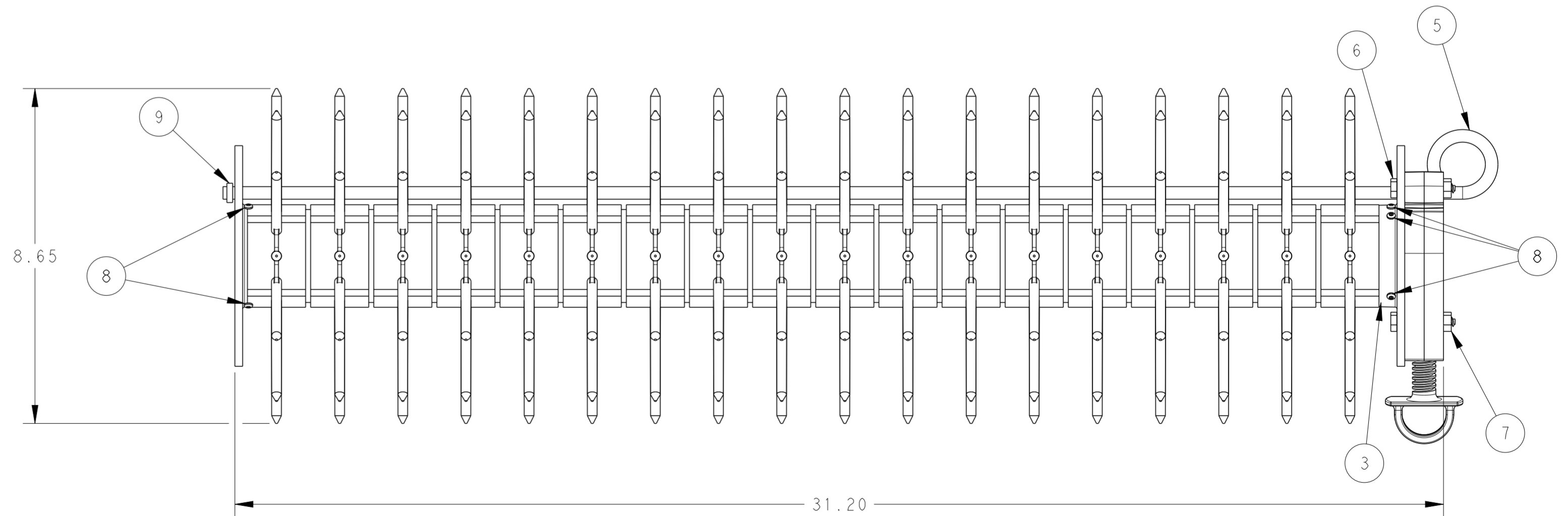
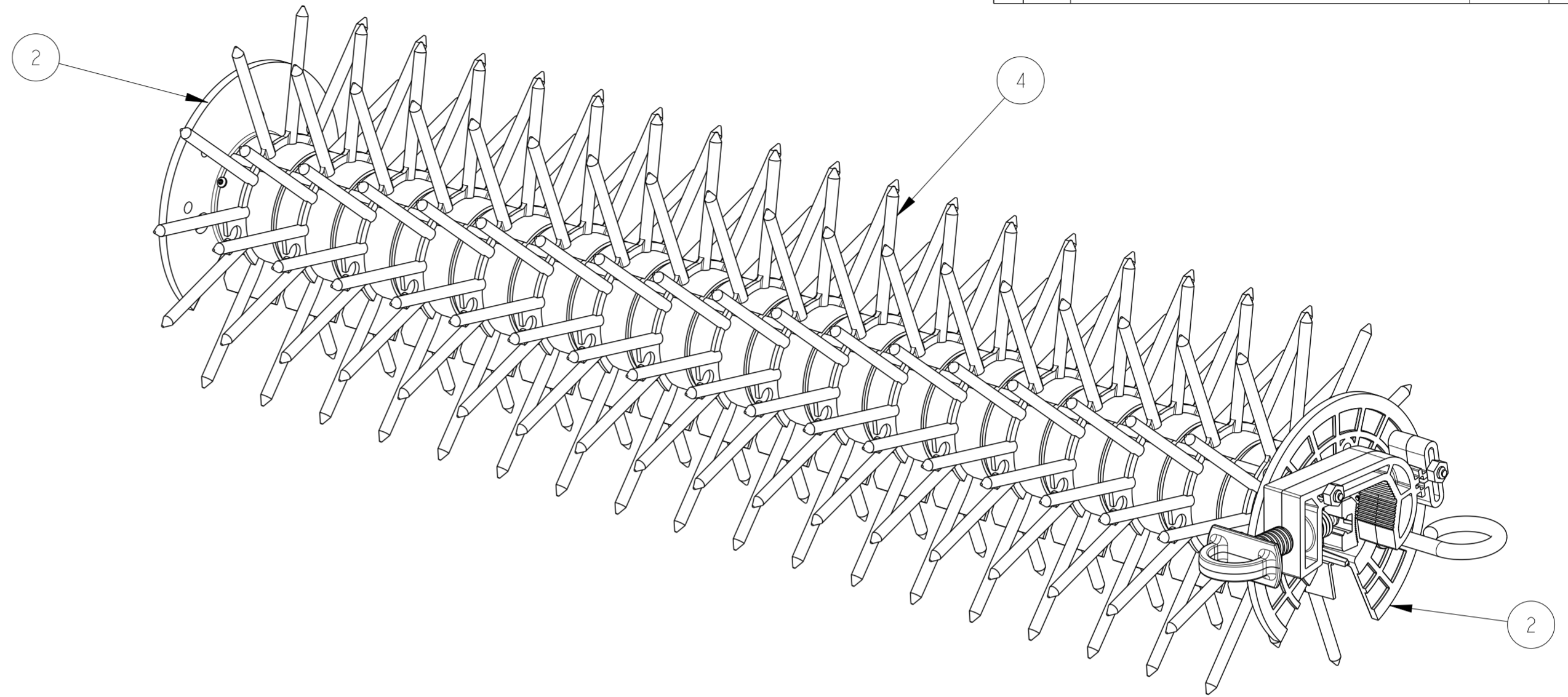

ITEM	DESCRIPTION	QTY
1	WLG-CLAMP	1
2	WLG-ENDPLATE	2
3	WLG-TUBE	1
4	WLG-STAR	18
5	WLG-ROD	1
6	SS BOLT	2
7	SS NUT	2
8	SS SCREWS	8
9	WASHER	1

THIS DRAWING IS A CONTROLLED DOCUMENT.		DWN SI 14APR2020	 TE Connectivity
DIMENSIONS: in		CHK LH 14APR2020	
TOLERANCES UNLESS OTHERWISE SPECIFIED: 0 PLC ±.1 1 PLC ±.05 2 PLC ±.02 3 PLC ±.005 4 PLC ±.0005 ANGLES ±.1 FINISH -		APVD LH 14APR2020	
MATERIAL		PRODUCT SPEC -	
		APPLICATION SPEC -	NAME WLG-60 ASSEMBLY
		WEIGHT -	SIZE A200779
		CUSTOMER DRAWING	DRAWING NO C-E00000740
		SCALE 3:10	RESTRICTED TO -
		SHEET 2 OF 2	REV C