

P	LTR	DESCRIPTION	DATE	DWN	APVD
A		INITIAL RELEASE	12OCT2020	SL	LH
A2		REV.PER ECN-24-273738	03MAY2024	SP	LH

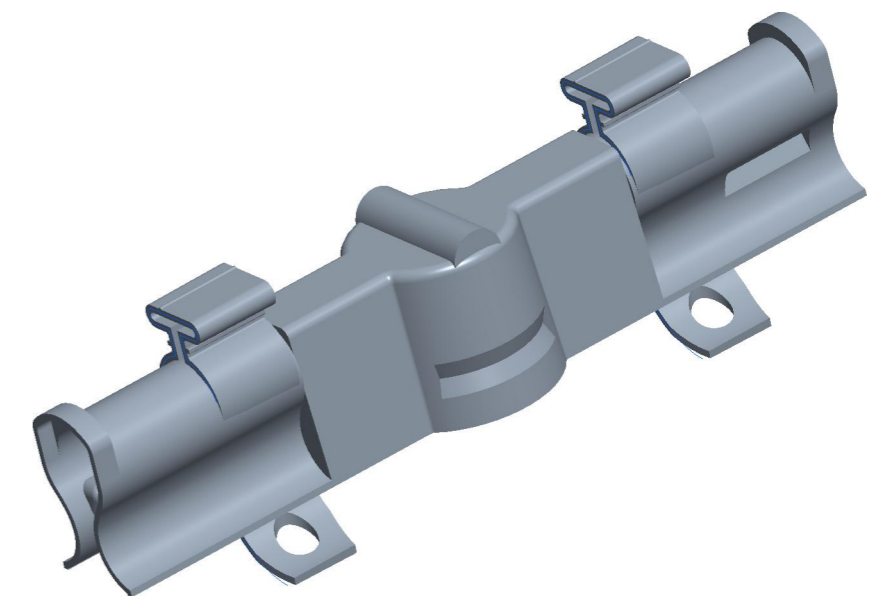

SCALE 1:4

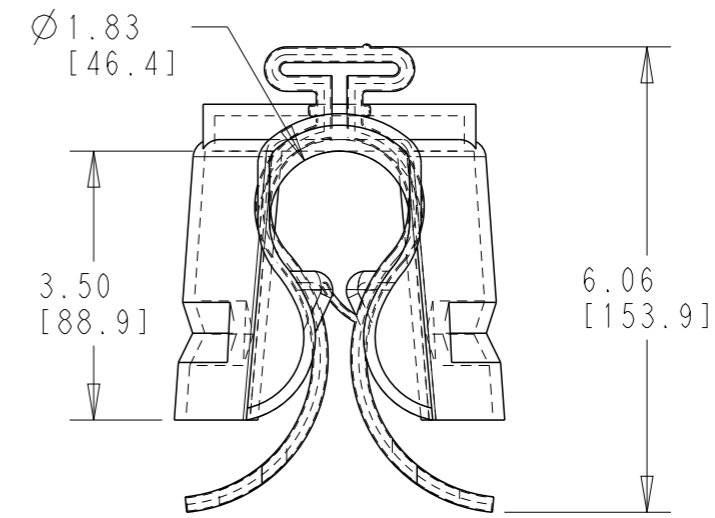
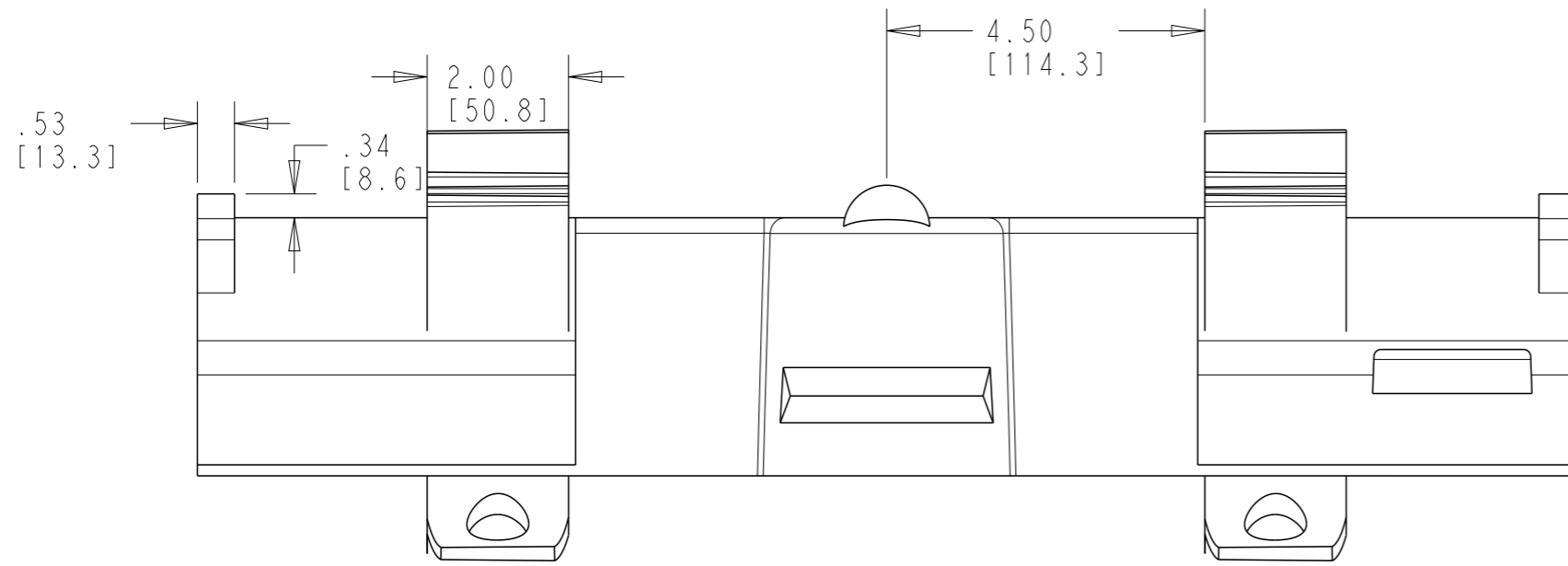
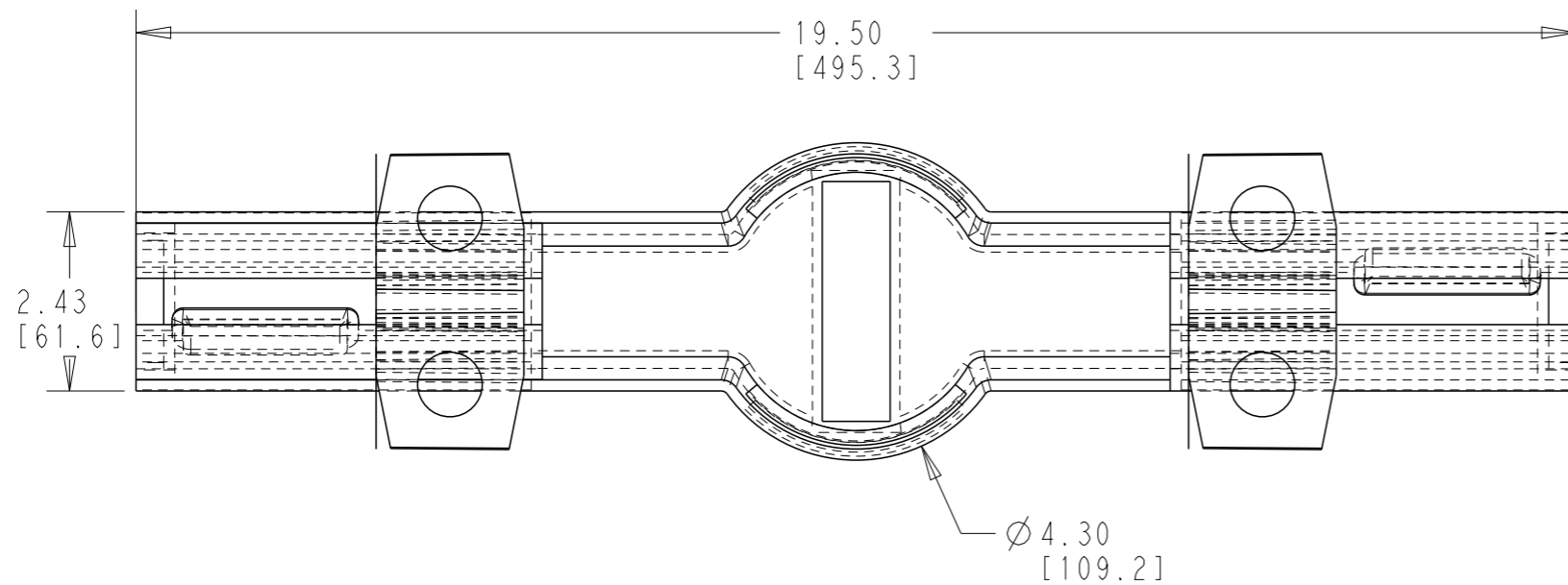

NOTES:

- PARTS TO BE KITTED 6 PIECES PER BOX.
- PART SHALL BE KITTED WITH PII-70140.
- EACH BOX SHALL BE LABELLED WITH DESCRIPTION, LOT NUMBER, PART NUMBER MANUFACTURING DATE AND QUANTITY.

THIS DRAWING IS A CONTROLLED DOCUMENT.		DWN	SL	12OCT2020						
DIMENSIONS: in [mm]		CHK	LH	12OCT2020				NAME BCIC-GT-PIN		
		APVD	LH	12OCT2020				PRODUCT SPEC -		
TOLERANCES UNLESS OTHERWISE SPECIFIED:		APPLICATION SPEC -						SIZE A3		
0 PLC ±- 1 PLC ±.1 2 PLC ±.01 3 PLC ±.001 4 PLC ±.0001 ANGLES ±-		WEIGHT			CAGE CODE	DRAWING NO	RESTRICTED TO			
MATERIAL TE GRAY		CUSTOMER DRAWING			00779	©-E00001652	-			
FINISH		SCALE			2:5	SHEET	1 OF 1			
		REV			A2					