

REVISIONS					
P	LTR	DESCRIPTION	DATE	DWN	APVD
A		PRELIMINARY DRAWING	22SEP2022	MS	WDE

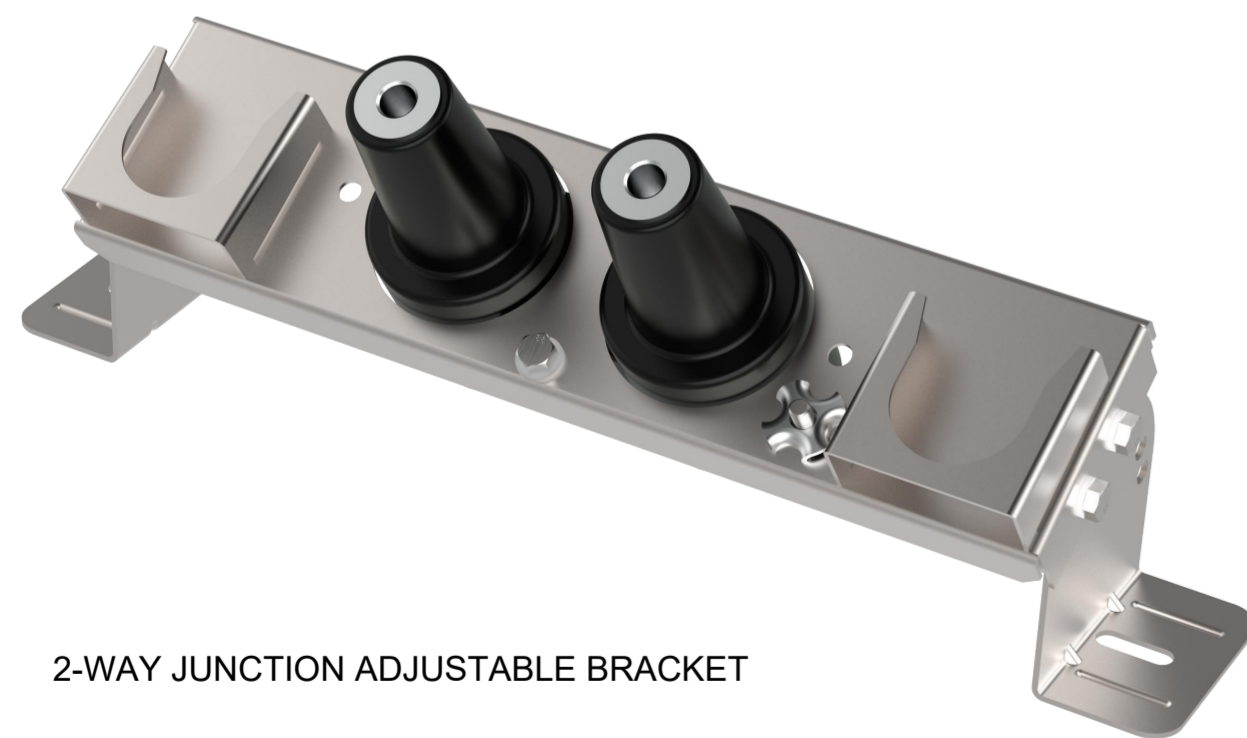

2-WAY JUNCTION ADJUSTABLE BRACKET

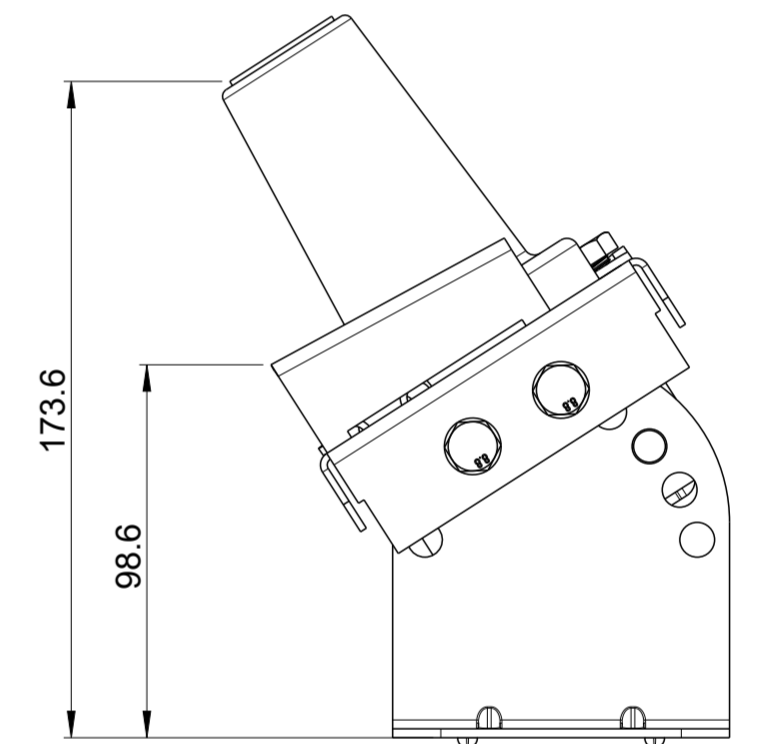
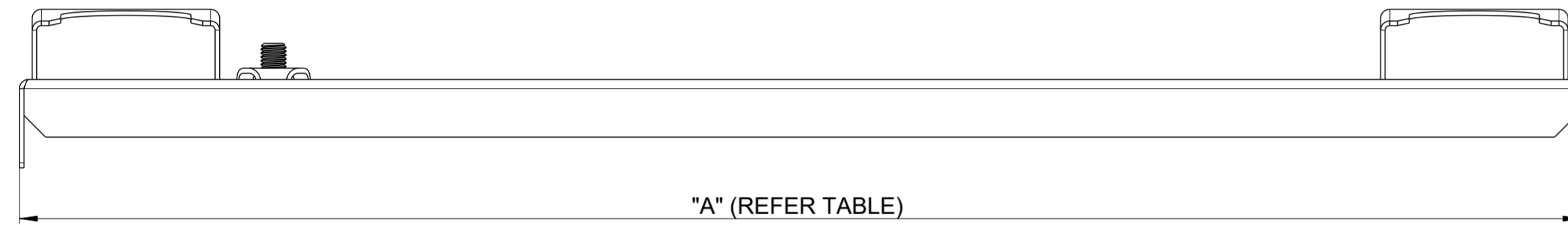
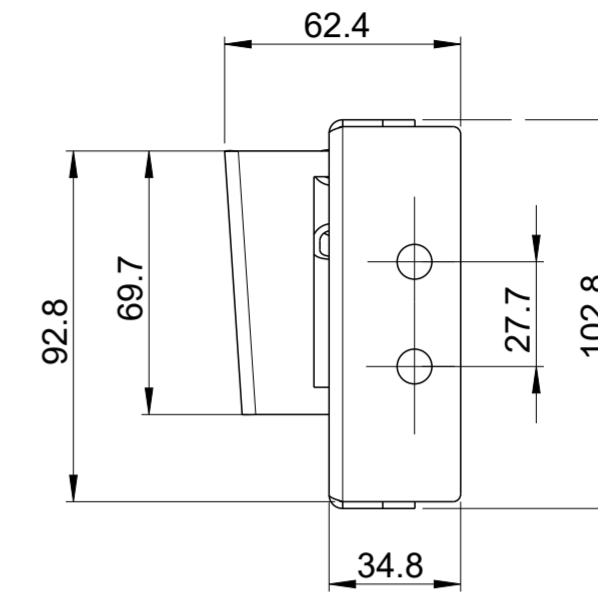
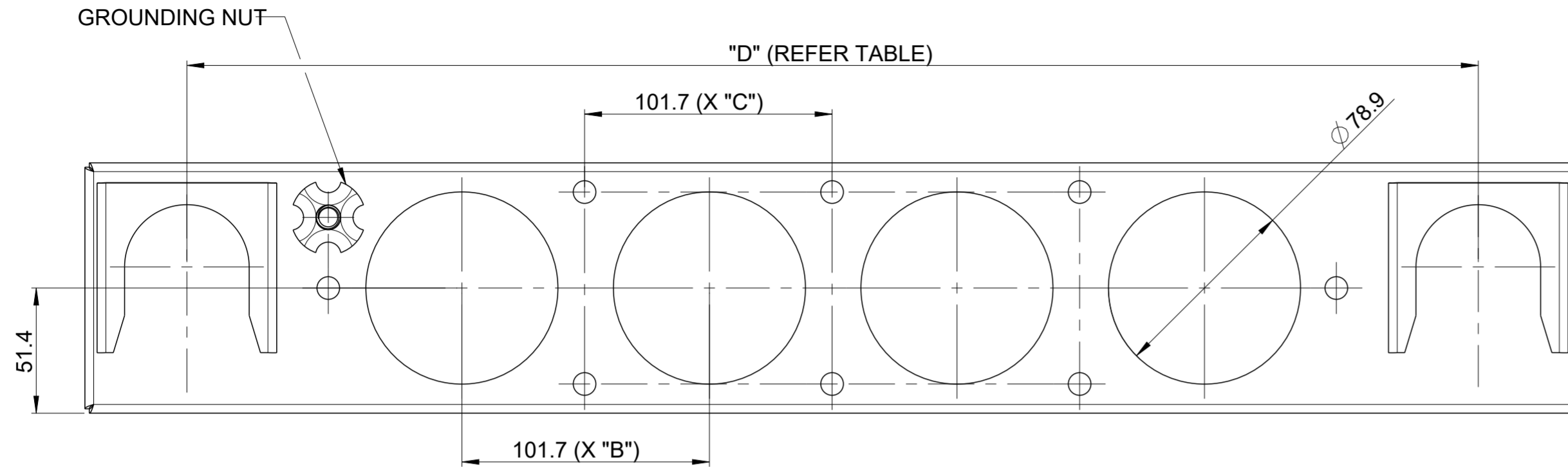

3-WAY JUNCTION ADJUSTABLE BRACKET

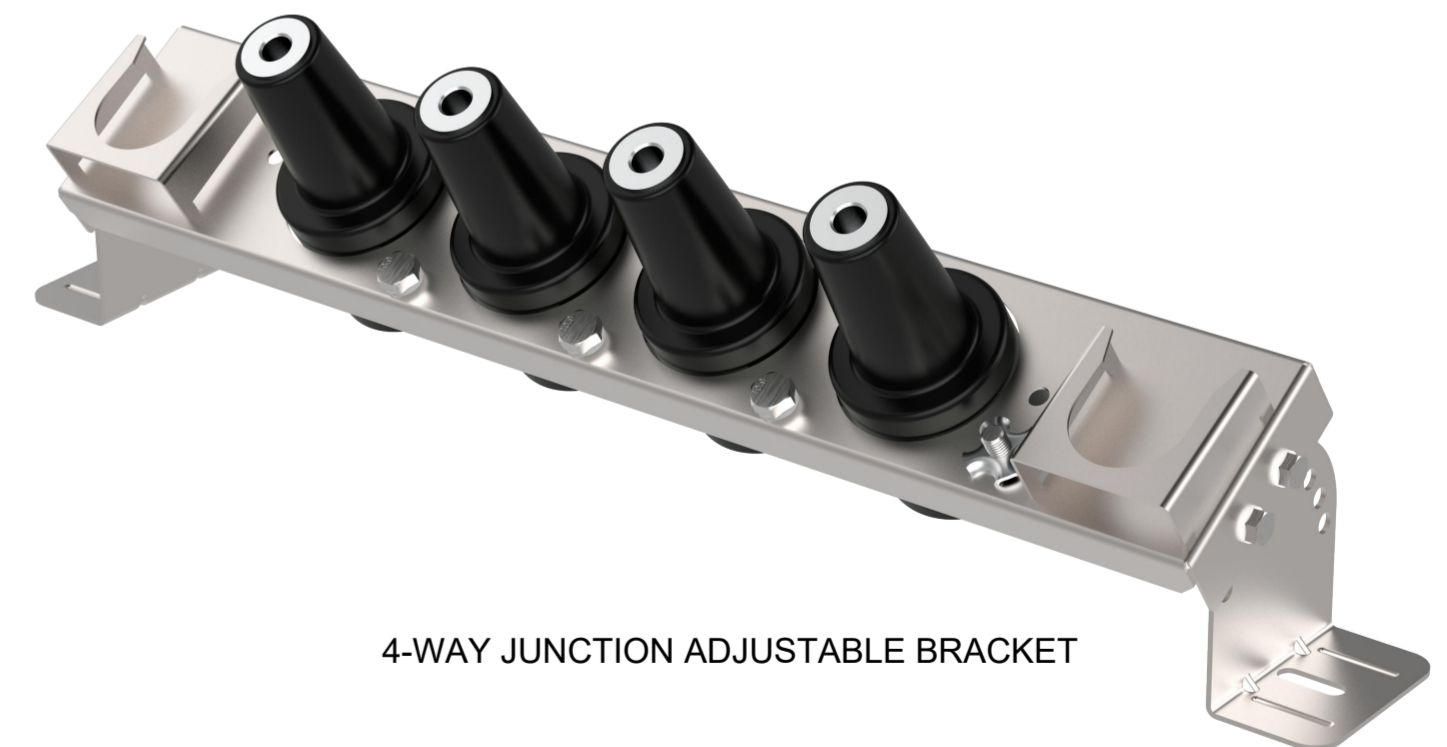

4-WAY JUNCTION ADJUSTABLE BRACKET

PART NUMBER	DESCRIPTION	POSITION	DIMENSION "A"	DIMENSION "D"	X "B"	X "C"
ED0501-000	ELB-15/28-600-J2-AL-ADJ	2	410.5	327.9	1	0
ED0502-000	ELB-15/28-600-J3-AL-ADJ	3	512.6	428.8	2	1
ED0503-000	ELB-15/28-600-J4-AL-ADJ	4	614.4	530.6	3	2

THIS DRAWING IS A CONTROLLED DOCUMENT.

DIMENSIONS:	TOLERANCES UNLESS OTHERWISE SPECIFIED	DWN	22SEP2022	 TE Connectivity
mm		CHK	22SEP2022	
		APVD	22SEP2022	
		PRODUCT SPEC		
MATERIAL	FINISH	WEIGHT		NAME
STAINLESS STEEL	finish_spec_2			ELB-15/28KV-600-J2-A-BKT
		CUSTOMER DRAWING		2, 3 AND 4 WAY JUNCTION BRACKET
		SCALE	5:1	SIZE
		SHEET	1 OF 1	A2
		REV	A	CAGE CODE
				00779
				DRAWING NO
				E00002078
				RESTRICTED TO
				-