

# MSD INC. — ENGINEERING DATA SHEET

RELAY TYPE: FCA-415-BY4 COMPUTER PART No.: 9244576

TEST PROCEDURE

CUSTOMER/SPECIFICATION: CATALOG ITEM | REV NONE

MSDP-79A

### TEST REQUIREMENTS

COIL RES.: 290 +/- 10% ohms OPERATE TIME: 15 mS Max RELEASE TIME: 15 mS Max

CONTACT MAKE BOUNCE: 1 mS Max N.O. BREAK BOUNCE: 0.1 mS MAX

CONTACT STABILIZATION TIME: N/A RATED COIL VOLTAGE: 28 Vdc

CONTACT RES.: MFG TEST: 8 Milliohms @ 10 mA FINAL TEST: 10 Milliohms @ 10 mA

CONTACT VOLTAGE DROP: FINAL TEST: 100 mV Max @ 10 A - 6 V dc

HI-POT: 1250 V rms ALL POINTS, EXCEPT 1000 V rms COIL TO CASE

INSULATION RESISTANCE: 100 Megohms Min @ 500 V dc

VIBRATION: N/A

SEAL TEST: 1X10<sup>-8</sup> Max LEAK RATE COIL TRANSIENT SUPPRESSION: 42 Vdc MAX

OTHER: \_\_\_\_\_

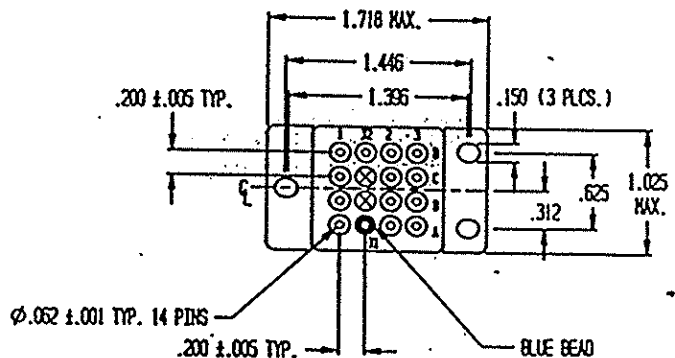
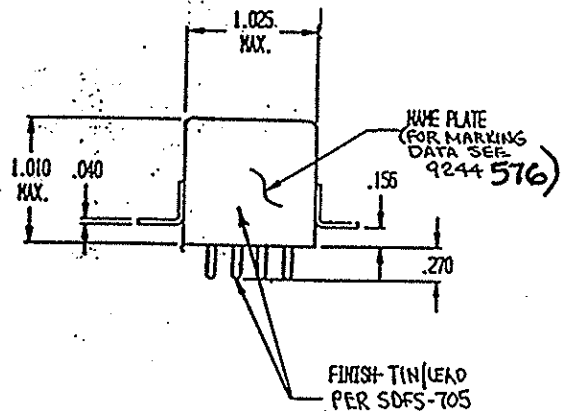

Prepared By: Date		Approved By: Date	
LES WYNNE 3-3-97			
Rev	ECN No.	Date	

### SPECIAL INSTRUCTIONS