

Mounting Dimensions

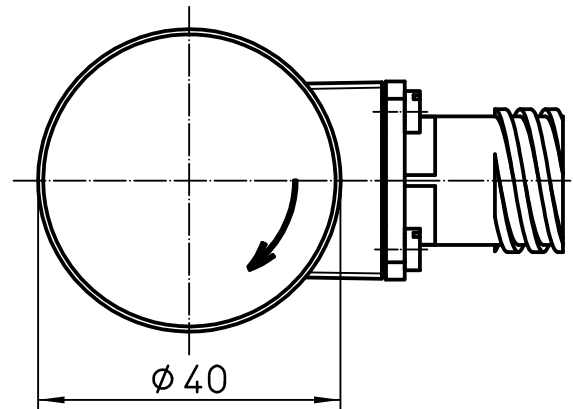

Wiring Diagram

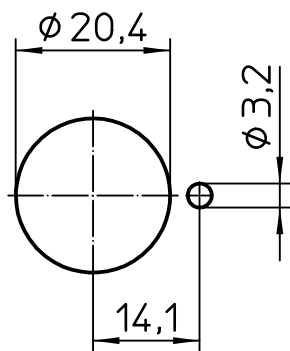
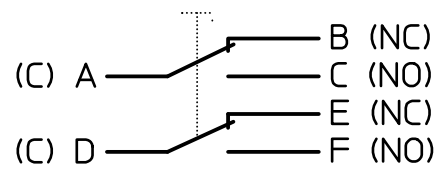

	Date	Name	mm	Scale	 Elektrotechnik - GmbH & Co KG D - 72218 Wildberg	Drawing No:
Drawn	28.01.2009	Stock	General Tolerances DIN ISO 2768 cL	1:1		G13-01-1801
Check	19.10.2015	Stock				NSN.:

Description of Function

The switch G13-01-1801 is a manually operated switch with a locking mechanism and two switching positions. The change-over from switching position 1 (as shown on drawing) into switching position 2 occurs whenever the actuation knob has been firmly pressed down. The switch remains locked in switching position 2. Twisting the actuation knob into the direction of the arrow will cause release of the locking mechanism and the switch will snap back into switching position 1.

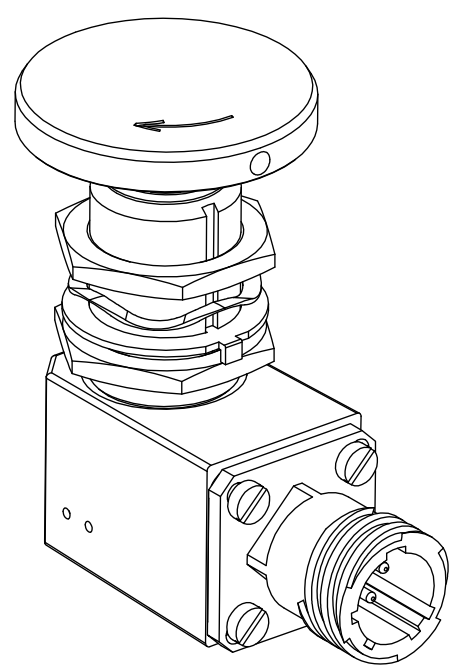

Characteristics

Pretravel	2,5 mm max.
Locks at (Position 2)	5 mm
Totaltravel	6 mm
Operating force to locking mechanism	app. 60 N
Temperature range	-55 °C to +85 °C
Sealing IEC 60529	IP 67 (0,2 bar; 5 min)
Vibration iaw MIL-STD-202; Method 204; Test condition B(10-2000 Hz)	15 g
Shock iaw MIL-STD-202; Method 213; Test condition I(6 ms; Sawtooth)	100 g
Insulation resistance iaw MIL-STD-202; Method 302; Test condition B(500 V; 60 s)	100 MOhm min.
Dielectric withstanding voltage iaw MIL-STD-202; Method 301	1050 V
Voltage	28 VDC
Current	7 Amps
Electrical rating, resistive load	28 VDC; 7 Amps
Electrical rating, inductive load	28 VDC; 4 Amps
Endurance iaw MIL-S-8805; §4.8.26 (28 VDC; 5 Amps)	10.000 Cycles
Endurance, mechanical	10.000 Cycles min.
Weight	0,17 kg
Switch insert MS 24547-1 iaw MIL-S-8805 to +82 °C	
max. Torque on the knob	5 Nm

	Date	Name	mm	Scale	 Elektrotechnik - GmbH & Co KG D - 72218 Wildberg	Drawing No:
Drawn	28.01.2009	Stock	←	1:1		G13-01-1801
Check	19.10.2015	Stock	General Tolerances DIN ISO 2768 cL			NSN.: