

# SPECIFICATION CONTROL DRAWING

REV: <b>1</b>	DATE: FEB 18, 2005
------------------	-----------------------

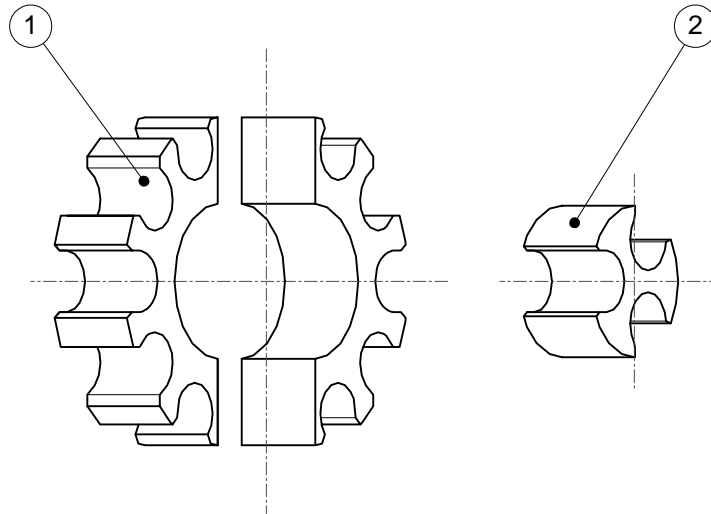

### KIT DESCRIPTION

ITEM	DESCRIPTION	MATERIAL
1	STAR - SPLIT	ALUMINIUM ALLOY
2	STAR - PLAIN	ALUMINIUM ALLOY

### ORDER INFORMATION

BASIC ORDER NUMBER	TOTAL FERRULE QUANTITY	SPLIT STAR FERRULE QUANTITY	PLAIN STAR FERRULE QUANTITY
A6	7	6	1*
A10	11	10	1*
	12		2
	13		3
	15		5
A12	13	12	1*
	14		2
	15		3
	17		5
	18		6

\* AS THERE IS NO SINGLE FERRULE PLAIN STAR, THE SPLIT STAR IS DESIGNED TO ACCEPT A SINGLE HET FERRULE

		<p style="text-align: center;"><b>Raychem</b> 300 Constitution Drive Menlo Park, CA 94025, USA</p>		TITLE: <b>HEXASHIELD SPLIT STARS ASSEMBLY</b>	
UNLESS OTHERWISE SPECIFIED DIMENSIONS ARE IN MILLIMETERS. INCH DIMENSIONS ARE SHOWN IN BRACKETS		Tyco Electronics reserves the right to amend this drawing at any time. Users should evaluate the suitability of the product for their application.		DOCUMENT NO. <b>HEX02-AY-AYY-2/YY</b>	
DRAWN: IRT	DATE: DEC 2003	DCR # D050051	FILE: 87005/02-2	SCALE: NONE	SHEET: 1 OF 2

# SPECIFICATION CONTROL DRAWING

REV: <b>1</b>	DATE: FEB 18, 2005
------------------	-----------------------

## PART NUMBERING

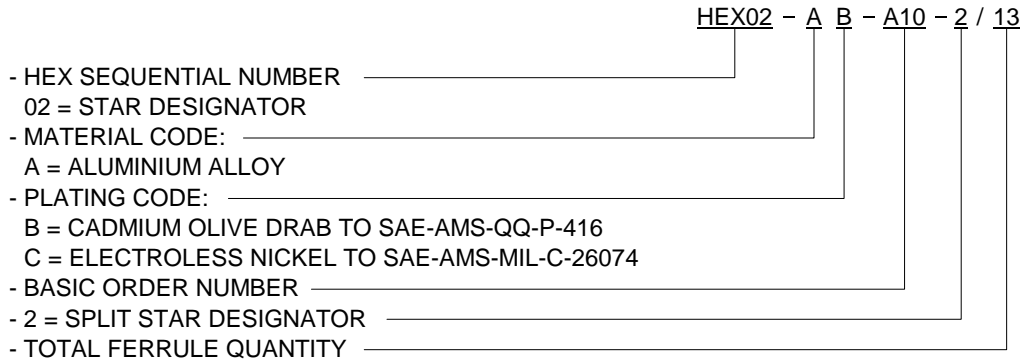

## APPLICATION

- These Star assemblies are optional to the Standard Stars normally supplied with the HEX range of adaptors and can replace the existing star or be ordered separately. The basic Order Number relates directly to the original HEX adaptor Order Number, and MUST be adhered to at all times.
- The Stars are used in conjunction with Ferrules HET-A-0XX, which are purchased separately. Refer to HET-A-0XX S.C.D. for relevant selection details.
- As this design offers more terminations than the standard HexaShield assemblies, installation should be carefully checked for suitability.
- If in doubt contact Tyco Electronics for further information and advice.

## INSTALLATION

- See Installation Procedure RPIP-696-04 for straight body adaptors.
- See installation Procedure RPIP-696-07 for 90° or 45° adaptors.

## PACKAGING

- All components are supplied bagged and labelled with relative Part and Batch Numbers.

		<b>Raychem</b> <small>300 Constitution Drive Menlo Park, CA 94025, USA</small>		TITLE: <h3 style="text-align: center; margin: 0;">HEXASHIELD SPLIT STARS ASSEMBLY</h3>	
UNLESS OTHERWISE SPECIFIED DIMENSIONS ARE IN MILLIMETERS. INCH DIMENSIONS ARE SHOWN IN BRACKETS		Tyco Electronics reserves the right to amend this drawing at any time. Users should evaluate the suitability of the product for their application.		DOCUMENT NO. <h3 style="text-align: center; margin: 0;">HEX02-AY-AYY-2/YY</h3>	
DRAWN: IRT	DATE: DEC 2003	DCR # D050051	FILE: 87005/02-2	SCALE: NONE	SHEET: 2 OF 2