

P	LTR	DESCRIPTION	DATE	DWN	APVD
	A	INITIAL RELEASE	21SEP2020	GK	MN

LABEL AND LINER DESIGN

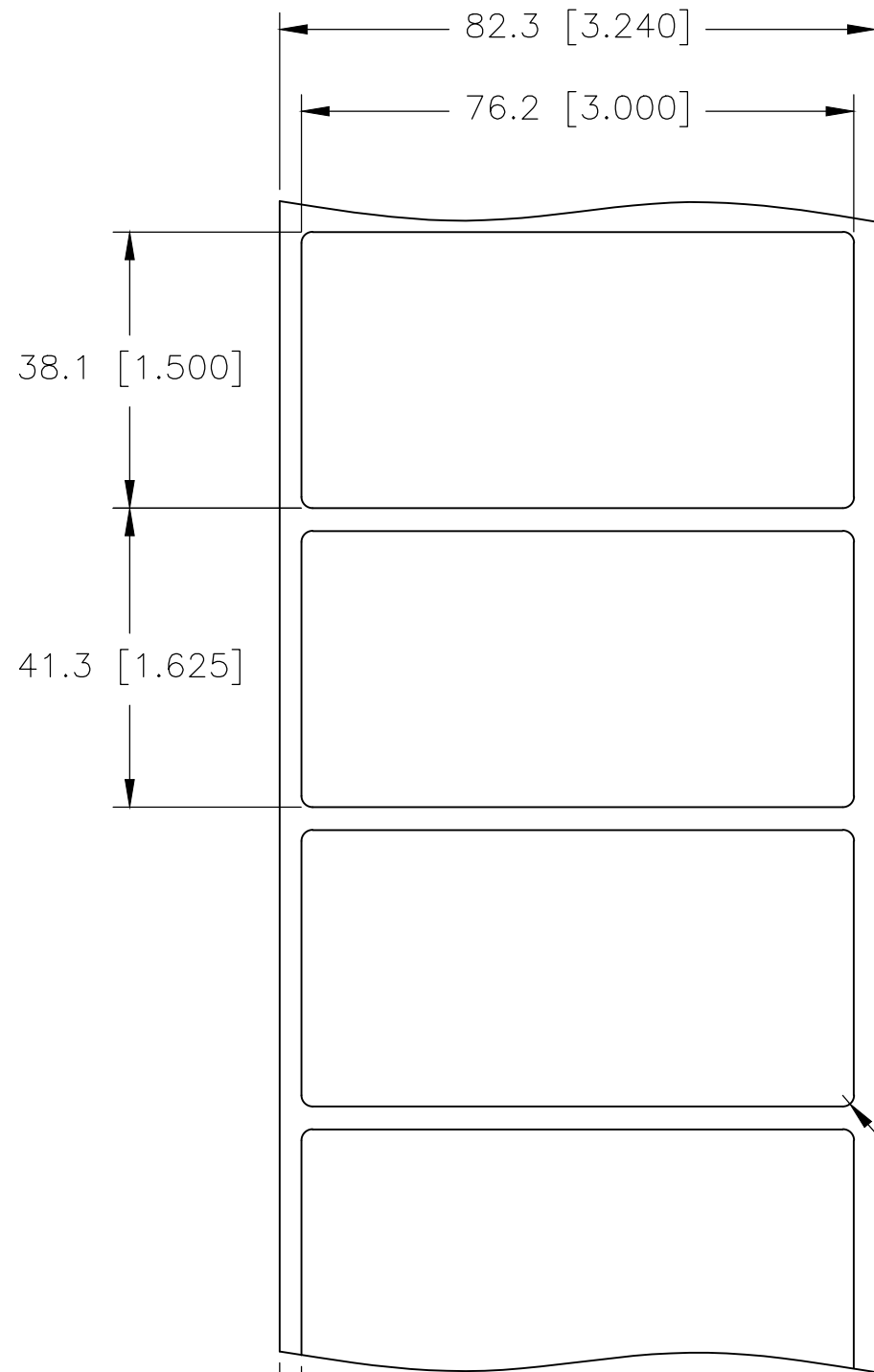

PRESENTATION

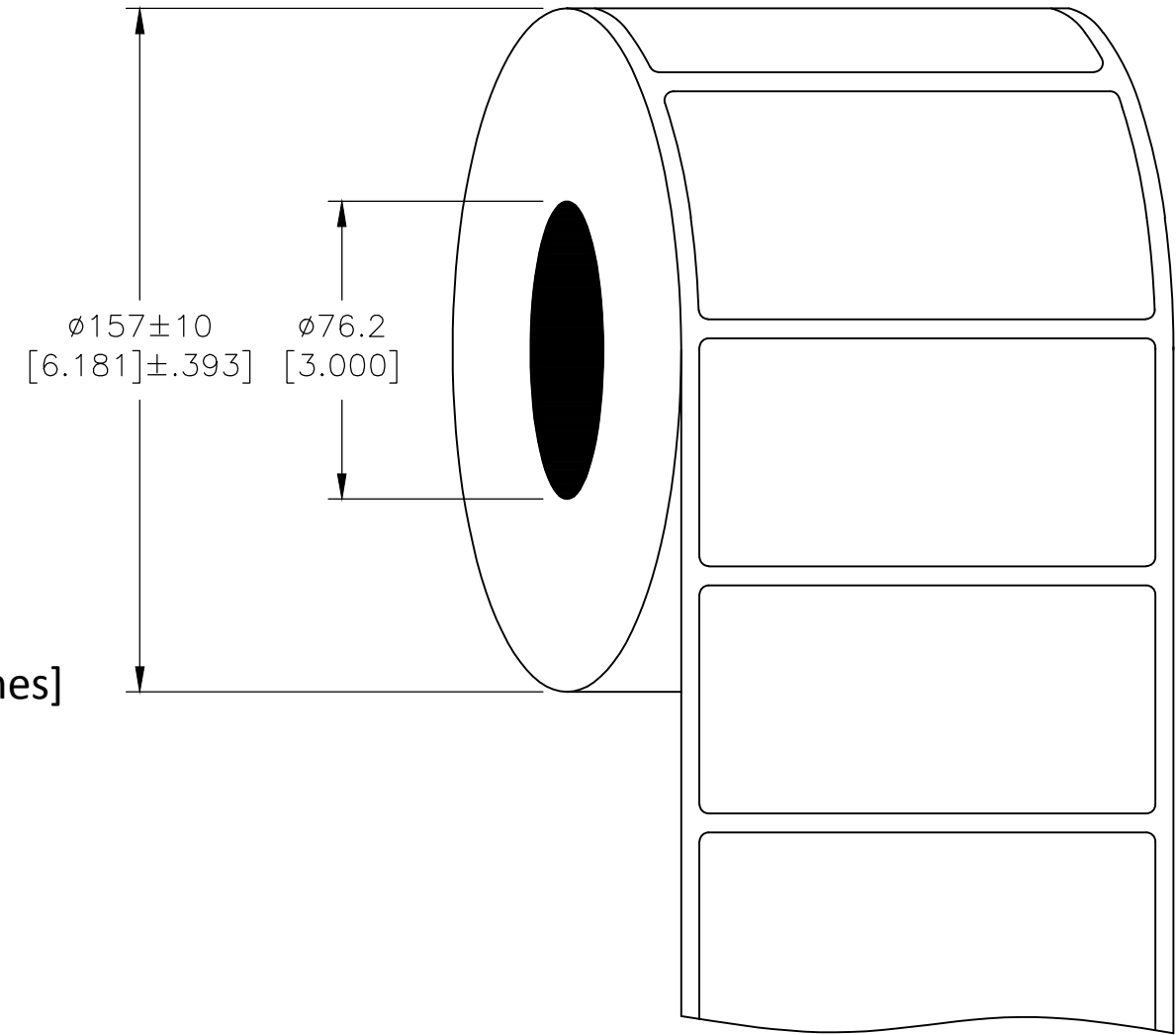

All dimensions in mm [Inches]

TE PN: A41129-000

**OUTSIDE WOUND
LABEL ACROSS: 1
PER ROLL QTY: 2500**

R1.5 [R.060]

MATERIAL	HIGH TACK METALIZED POLYESTER
ADHESIVE TYPE	PERMANENT ACRYLIC
LINER	GLASSINE PAPER

THIS DRAWING IS A CONTROLLED DOCUMENT.

TOLERANCES mm [INCH]	
LABEL HEIGHT:	±0.3 [.012]
LABEL WIDTH:	±0.3 [.012]
WEB WIDTH:	±0.8 [.031]
VERTICAL REPEAT:	±0.8 [.031]*
HORIZONTAL REPEAT:	±0.8 [.031]*
PRINT POSITIONING:	±0.8 [.031]*
LEFT MARGIN:	±0.4 [.016]
QUANTITY:	-0 % +2 %
*NON ACCUMULATING	

DIMENSIONS:	TOLERANCES UNLESS OTHERWISE SPECIFIED:
mm [INCHES]	
	0 PLC ± -
	1 PLC ± -
	2 PLC ± -
	3 PLC ± -
	4 PLC ± -
ANGLES	± -
FINISH	-

DWN	21SEP2020	TE Connectivity	NAME HM - HIGH TACK METALIZED POLYESTER LABELS			
CHK	21SEP2020					
APVD	21SEP2020					
APVD	21SEP2020					
PRODUCT SPEC	TTDS-075	SIZE	CAGE CODE	DRAWING NO	RESTRICTED TO	
APPLICATION SPEC	-	A3	C2290	C-HM-762381-2.5-8A	-	
WEIGHT	0.332g	CUSTOMER DRAWING		SCALE	SHEET	REV
				NTS	1 OF 1	A