

REVISIONS

P	LTR	DESCRIPTION	DATE	DWN	APVD
	4	RELEASED AS PER ECO-17-009529	03JUL2017	PV	MP

a) Part as supplied.

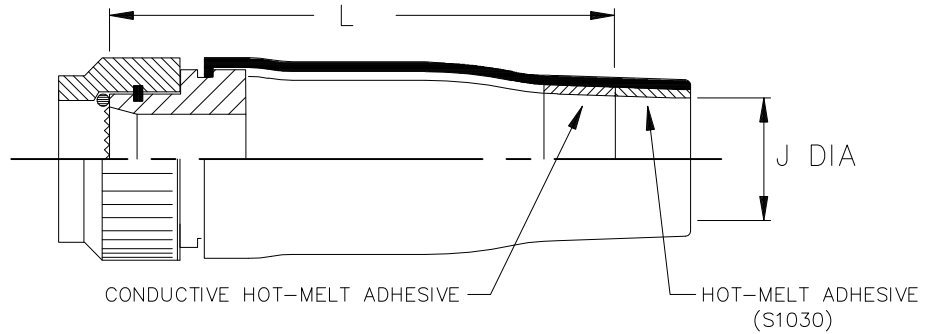

b) Part after unrestricted recovery.

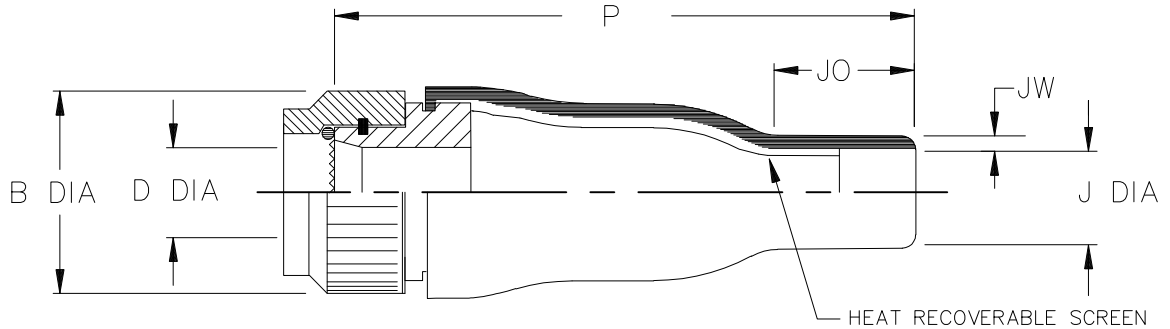

NOTES:

Raychem Connector Code: 79
 Connector Series: (PATT 608)
 Adaptor Series: 229M1**-01-W**-K-NS
 Nickel Aluminium Bronze to BS2874 CA104 or ASTM C 63200 or ASTM B150
 Unplated, Shotblast - Glass Bead
 Moulded Part Material: -100C (Black); Polyolefin/Silver Composites, Semi-flexible
 ZEROHAL™ Low fire hazard

Kits to include cleaning tissue, 1 piece 100 grit emery cloth & packing piece.
 Kit to be used in conjunction with installation guide for straight assemblies.

Dimensions in mm [inches for reference]

Part No.	Shell Size	B DIA MAX	D DIA MIN	J		P ±10% b	L REF a	JO REF b	JW ±30% b
				MIN a	MAX b				
KTKK0444A	08	19.4 [.76]	8 [.31]	9 [.35]	6.0 [.24]	70 [2.76]	64 [2.52]	17 [.67]	1.0 [.04]
KTKK0445A	10	21.4 [.84]	11 [.43]	11 [.43]	7.2 [.28]	82 [3.23]	76 [2.99]	20 [.79]	1.0 [.04]
KTKK0446A	12	24.4 [.96]	14 [.55]	17 [.67]	8.5 [.33]	95 [3.74]	86 [3.39]	25 [.98]	1.0 [.04]
KTKK0447A	14	29.3 [1.15]	17 [.67]	17 [.67]	8.5 [.33]	95 [3.74]	86 [3.39]	25 [.98]	1.0 [.04]
KTKK0448A	16	30.9 [1.22]	20 [.79]	21 [.83]	10.0 [.39]	120 [4.72]	108 [4.25]	30 [1.18]	1.2 [.05]
KTKK0449A	18	33.9 [1.33]	23 [.91]	21 [.83]	10.0 [.39]	120 [4.72]	108 [4.25]	30 [1.18]	1.2 [.05]
KTKK0450A	20	38.6 [1.52]	26 [1.02]	29 [1.14]	15.8 [.62]	145 [5.71]	130 [5.12]	30 [1.18]	1.5 [.06]
KTKK0451A	22	38.6 [1.52]	26 [1.02]	29 [1.14]	15.8 [.62]	145 [5.71]	130 [5.12]	30 [1.18]	1.5 [.06]
KTKK0452A	24	42.6 [1.68]	32 [1.26]	37 [1.46]	16.8 [.66]	116 [4.57]	102 [4.02]	38 [1.50]	2.4 [.09]

RELEASED FOR PUBLICATION

ALL RIGHTS RESERVED.

COPYRIGHT 2016 By TE Connectivity

THIS DRAWING IS UNPUBLISHED.

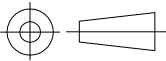
DIMENSIONS: mm [INCHES]	DWN P. VU	100CT2016	MATERIAL	SEE NOTES	FINISH	SEE NOTES
	CHK N. NAGAR	100CT2016	 TE Connectivity			
TOLERANCES UNLESS OTHERWISE SPECIFIED:	APVD M. POPE	100CT2016				
0 PLC ± -	PRODUCT SPEC	NAME				ADAPTOR ASSEMBLY
1 PLC ± -	—	APPLICATION SPEC				—
2 PLC ± -	—	SIZE	CAGE CODE	DRAWING NO	RESTRICTED TO	
3 PLC ± -	—	A4	00779	C-KTKK0444A-0452A	—	
4 PLC ± -	—	WEIGHT				—
ANGLES ± -	CUSTOMER DRAWING				SCALE	DNS
				SHEET	1 OF 1	REV 4