

REVISIONS

P	LTR	DESCRIPTION	DATE	DWN	APVD
	4	RELEASED AS PER ECO-17-009529	03JUL2017	KH	MP

a) Part as supplied.

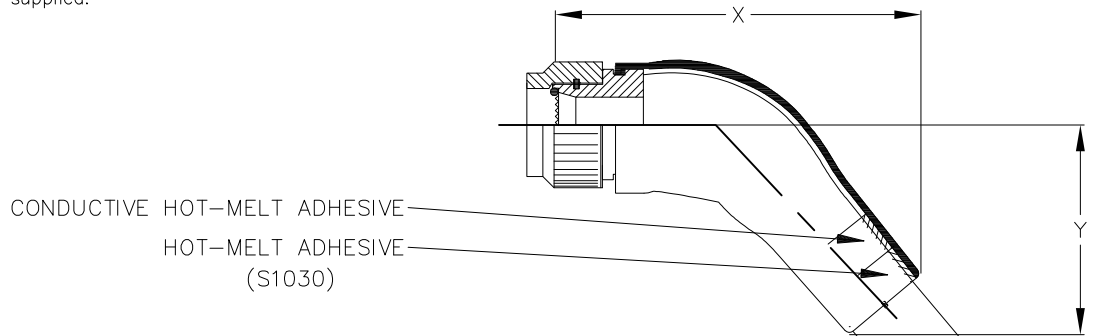

b) Part after unrestricted recovery.

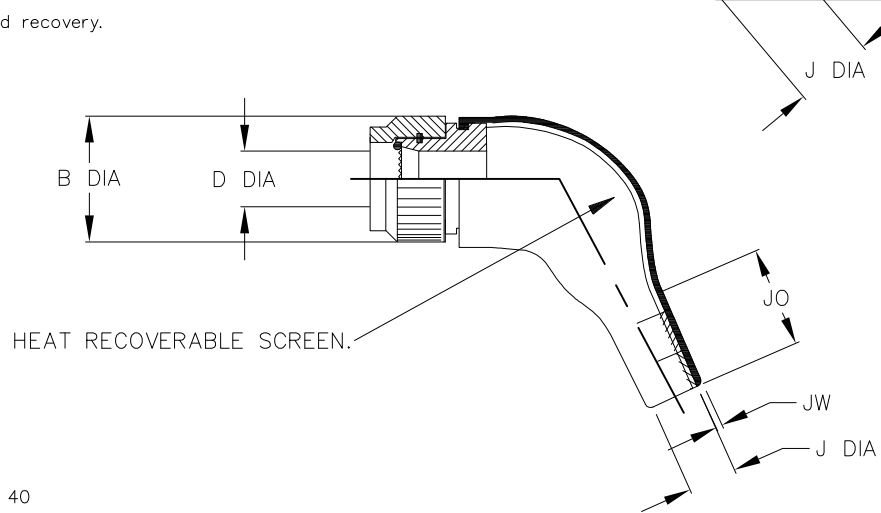

NOTES:

Raychem Connector Code: 40
 Connector Series: MIL-C-38999 SERIES 3 & 4
 Adaptor Series: 208M7**-01-W**-K-NS
 Nickel Aluminium Bronze to BS2874CA104 OR ASTM C 63200 OR ASTM B150
 Unplated, Shotblast - Glass Bead

Moulded Part Material: -100C (Black); Polyolefin/Silver Composites, semi-flexible
 ZEROHAL™ Low fire hazard

Kits to include cleaning tissue, 1 piece 100 grit emery cloth & packing piece.
 Kit to be used in conjunction with installation guide for 90 & 45 deg. assemblies.

Dimensions in mm [inches for reference]

Part No.	Shell Size	B DIA MAX	D DIA MIN	J		JO REF b	JW ±30% b	X ±20% a	Y ±20% a
				MIN a	MAX b				
KTKK3130	A	19.2 [.76]	6.2 [.24]	7 [.28]	5 [.19]	15 [.59]	1.0 [.04]	57 [2.24]	23 [.91]
KTKK3131	B	21.7 [.85]	9.3 [.37]	9 [.35]	6 [.24]	17 [.67]	1.0 [.04]	64 [2.52]	29 [1.14]
KTKK3132	C	25.5 [1.00]	12.8 [.50]	11 [.43]	7.2 [.28]	18 [.71]	1.0 [.04]	70 [2.76]	29 [1.14]
KTKK3133	D	29.3 [1.15]	14.1 [.56]	11 [.43]	7.2 [.28]	18 [.71]	1.0 [.04]	70 [2.76]	29 [1.14]
KTKK3134	E	31.9 [1.26]	18.8 [.74]	17 [.67]	8.5 [.33]	20 [.79]	1.0 [.04]	81 [3.19]	36 [1.41]
KTKK3135	F	35.7 [1.41]	18.8 [.74]	17 [.67]	8.5 [.33]	20 [.79]	1.0 [.04]	81 [3.19]	36 [1.41]
KTKK3136	G	38.2 [1.50]	23.6 [.93]	21 [.83]	10.0 [.39]	28 [1.10]	1.5 [.06]	97 [3.82]	45 [1.77]
KTKK3137	H	42.0 [1.65]	23.6 [.93]	21 [.83]	10.0 [.39]	28 [1.10]	1.5 [.06]	97 [3.82]	45 [1.77]
KTKK3138	J	44.6 [1.76]	30.9 [1.22]	29 [1.14]	15.8 [.62]	31 [1.22]	1.5 [.06]	118 [4.65]	59 [2.32]

THIS DRAWING IS UNPUBLISHED.

ALL RIGHTS RESERVED.

COPYRIGHT 2016 By TE Connectivity

DIMENSIONS:
mm [INCHES]

DWN K. HOLAL 14OCT2016
 CHK N. NAGAR 14OCT2016

MATERIAL SEE NOTES

FINISH SEE NOTES

TOLERANCES UNLESS OTHERWISE SPECIFIED:

APVD M. POPE 14OCT2016
 PRODUCT SPEC

NAME ADAPTOR ASSEMBLY



TE Connectivity

APPLICATION SPEC

SIZE A4 CAGE CODE 00779 DRAWING NO C-KTKK3130-3138

RESTRICTED TO

WEIGHT

CUSTOMER DRAWING

SCALE DNS

SHEET 1 OF 1

REV 4

