

REVISIONS

P	LTR	DESCRIPTION	DATE	DWN	APVD
	A	GTP ECN-23-221574	12JUL2023	DC	JH

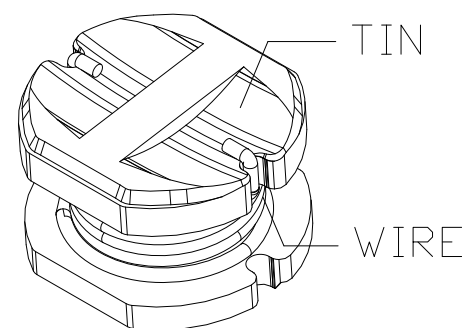
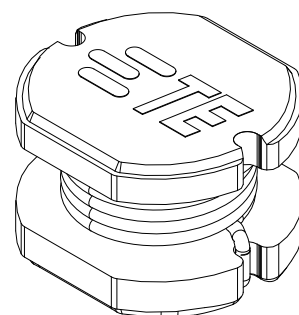
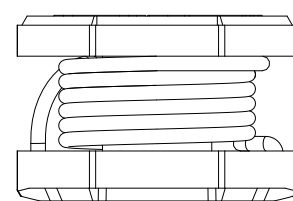
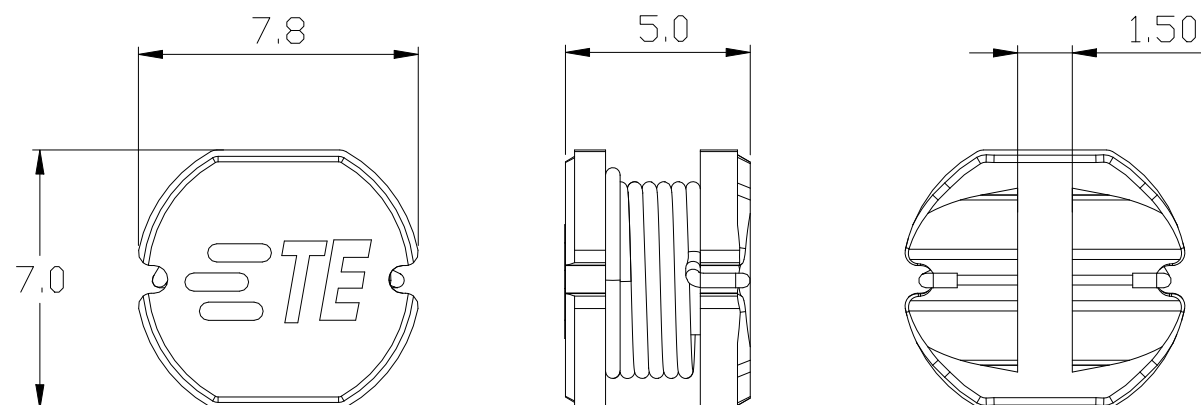

NOTE

1. FREQUENCY : 13.56MHZ
2. Ls:4.7uH ; Rs:0.250hm
3. SENSOR DISTANCE 35mm
4. SMD COMPATIBLE
5. OPERATING TEMPERATURE -40 TO +85
6. STORAGE TEMPERATURE -40 TO +85
7. MEET ROHS REQUIREMENT
8. CONSULT TE CONNECTIVITY DS_L000641
9. PACKAGE : REEL AND BOX

FOOTPRINT

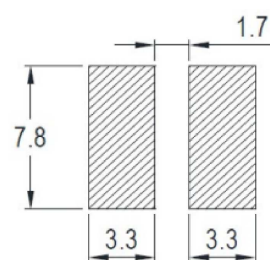

L000641-01

TE PN

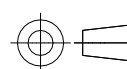
THIS DRAWING IS A CONTROLLED DOCUMENT.		DWN	DC	03JUL2023	 TE Connectivity					
DIMENSIONS: mm		CHK	SJ	03JUL2023				NAME		
		APVD	JH	03JUL2023				COIL ANT, SMT, 13.56MHZ NFC		
TOLERANCES UNLESS OTHERWISE SPECIFIED:		PRODUCT SPEC			-					
0 PLC ± -		APPLICATION SPEC			-					
1 PLC ± -		SIZE	A3	CAGE CODE	00779	DRAWING NO	C=L000641			
2 PLC ± 0.3		RESTRICTED TO			-					
3 PLC ± -		WEIGHT			-					
4 PLC ± -		CUSTOMER DRAWING			SCALE 1:1					
ANGLES ± -		SHEET			1 OF 2					
FINISH		REV			A					
-		-			-					

REVISIONS					
P	LTR	DESCRIPTION	DATE	DWN	APVD
-	-	SEE SHEET 1	-	-	-

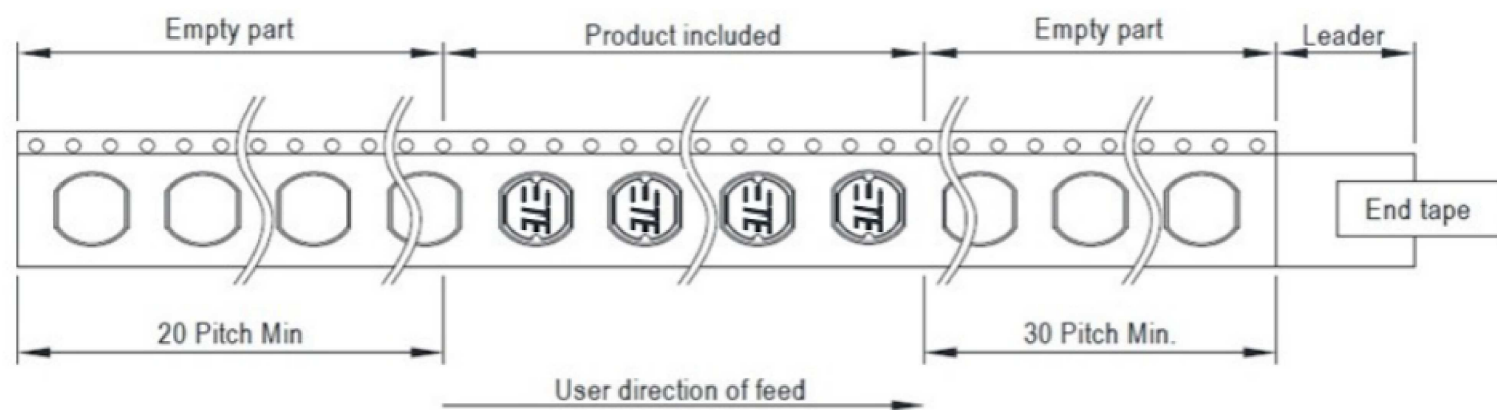

2 Inner boxes are per the out box. (4,000pcs.)

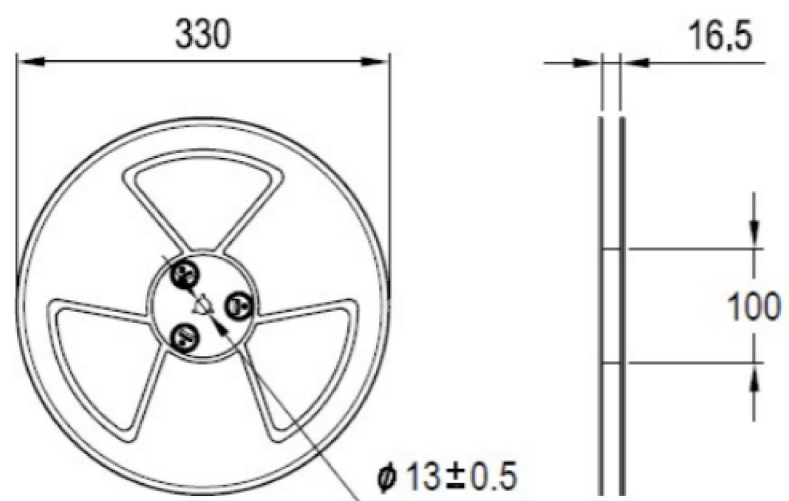

*Tape and reel packing with plastic bag.
 *1000 pcs/ Reel

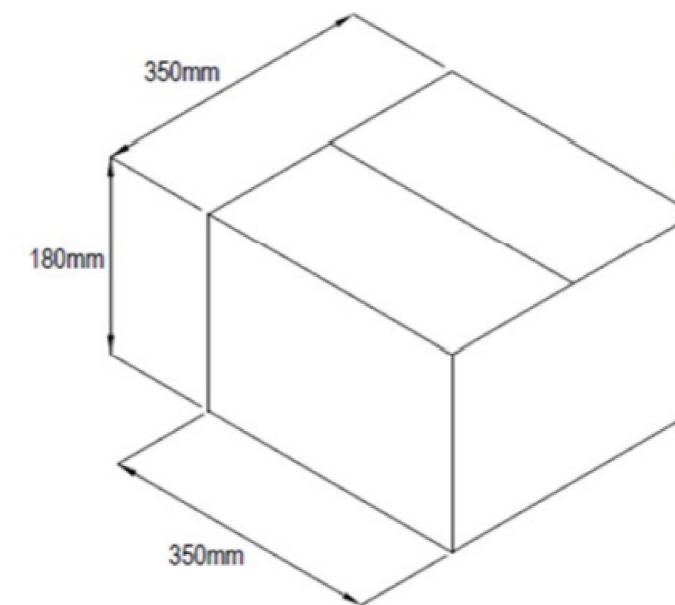
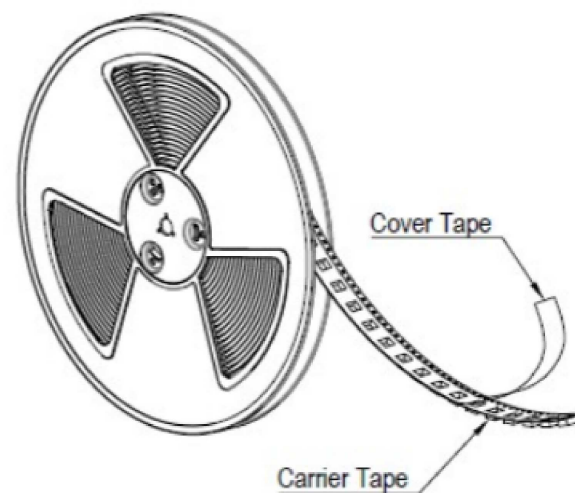

THIS DRAWING IS A CONTROLLED DOCUMENT.		DWN DC	03JUL2023	TE Connectivity	
		CHK SJ	03JUL2023		
		APVD JH	03JUL2023	NAME	
		PRODUCT SPEC		COIL ANT, SMT, 13.56MHZ NFC	
		APPLICATION SPEC		-	
		WEIGHT	-	SIZE	A3
		CUSTOMER DRAWING		CAGE CODE	00779
				DRAWING NO	C=L000641
				RESTRICTED TO	-
				SCALE	1:1
				SHEET	2 OF 2
				REV	A