

6

5

4

3

2

1

REVISIONS					
REV.	ECN#	ZONE	DESCRIPTION	CHANGED BY/DATE	APPROVED BY/DATE
AA	ECN-IAS-04857	ALL	INITIAL RELEASE	S.S. 20NOV15	R.H. 20NOV15

PARAMETER	PERFORMANCE
MODEL NUMBER	NMOHPCNSMAM518
FREQUENCY	0 - 6 GHz
WEIGHT	217g
IP RATING	OUT DOOR RATED
OPERATING TEMP	-30 °C TO +85 °C
CABLE TYPE	DUAL - SHIELDED LOW LOSS COAXIAL CABLE
CABLE LENGTH	5180
CONNECTOR	SMA - MALE INSTALLED
MOUNT TYPE	NMO
INSTALLATION HOLE SIZE	3/4"
HARDWARE	O-RING AND NMO RING ADAPTER INCLUDED

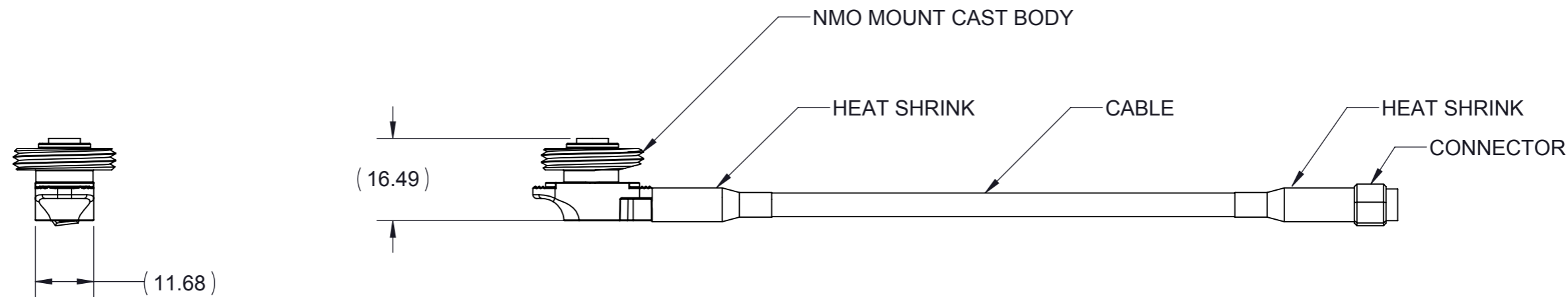

<b>MATERIAL:</b> N/A		THIRD ANGLE PROJECTION 
<b>FINISH:</b> N/A		
APPROVALS		DO NOT SCALE DRAWING
DRAWN BY	S. SAFVI	DATE
ELEC. ENG.	R. HARO	20NOV15
MECH. ENG.	S. SAFVI	20NOV15
MFG./OPS.	Y. CASTILLO	20NOV15

INTERPRET DIMENSIONING AND TOLERANCING IN ACCORDANCE WITH ASME Y14.5M-2009

**TOLERANCES UNLESS OTHERWISE SPECIFIED**

DIMENSIONS ARE IN MILLIMETERS

ANGLE: ±30'  
 0 PLACE DECIMAL: ±0.5  
 1 PLACE DECIMAL: ±0.25  
 2 PLACE DECIMAL: ±0.13

SURFACE ROUGHNESS 1.6/√

**Laird** SCHAUMBURG, IL 60173 USA

TITLE: **NMOHPCNSMAM518 MOUNTING & OUTLINE**

SIZE: **A3** DWG. NO.: **NMOHPCNSMAM518MO** REV: **AA**

SCALE: 1:2 PREVIOUS# SHEET 1 OF 1

UNLESS OTHERWISE NOTED, THIS DOCUMENT CONTAINS LAIRD TECHNOLOGIES CONFIDENTIAL INFORMATION. REPRODUCTION, USE, DISCLOSURE OR TRANSMITTAL OF ALL OR ANY PART OF THIS DOCUMENT IS PROHIBITED EXCEPT TO THE EXTENT APPROVED IN WRITING BY AN AUTHORIZED REPRESENTATIVE OF LAIRD TECHNOLOGIES. LAIRD TECHNOLOGIES RESERVES ALL RIGHTS UNDER PATENTS, TRADEMARKS, COPYRIGHTS AND TRADE SECRETS. COPYRIGHT, LAIRD TECHNOLOGIES 2014, ALL RIGHTS RESERVED.

6

5

4

3

2

1