

ANGLE 1

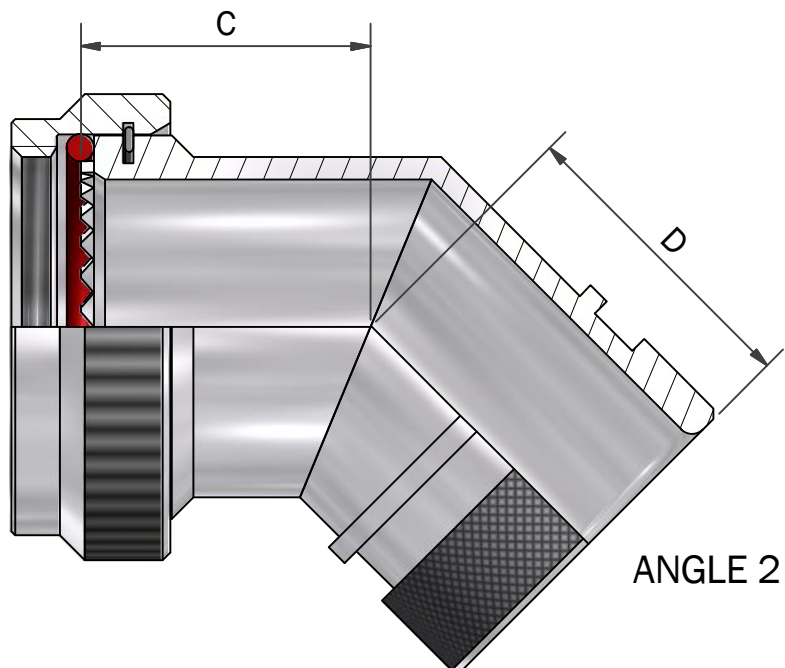

ANGLE 2

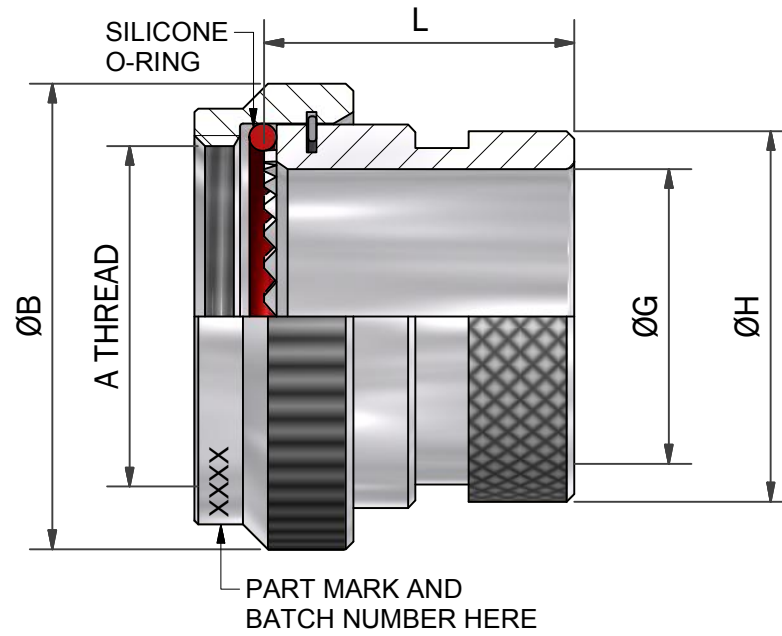
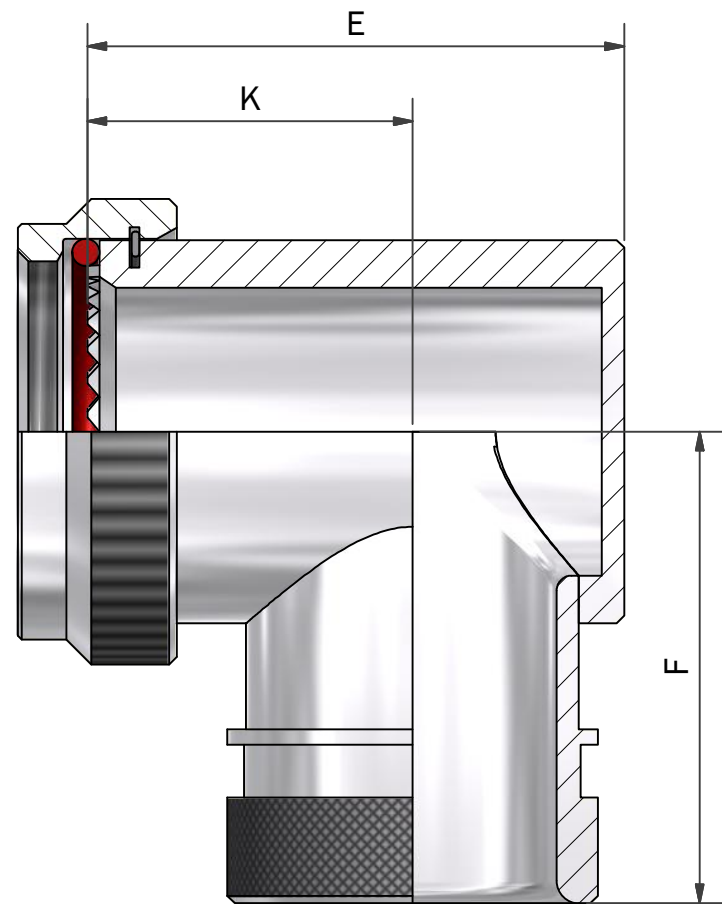

ANGLE 3



DRAWN	J.CLARK	DATE 23/02/2009	 3RD ANGLE PROJECTION NOT TO SCALE	 POLAMCO LTD WESTON LOCK LOWER BRISTOL ROAD BATH BA2 1EP	PAGE 1	UNLESS OTHERWISE SPECIFIED ALL DIMENSIONS IN MILLIMETRES
SALES APPR						
DESIGN APPR			THIS DRAWING IS COPYRIGHT AND THE PROPERTY OF POLAMCO LTD IT MUST NOT BE COPIED, USED FOR MANUFACTURE OR OTHERWISE DISCLOSED WITHOUT PRIOR WRITTEN CONSENT OF THE COMPANY.	ASSY USED ON: MIL-DTL-38999 SERIES II	MATERIAL ALUMINIUM ALLOY	NCAGE CODE U5792
QUAL APPR						
ISSUE 6	DCR 6245					
WEIGHT	GENERAL TOL LINEAR +/-0.1MM ANGULAR +/- 1°		PART NUMBER: 97F SERIES			

TABLE 1

SHELL SIZE	A THREAD	ØB MAX	ØG MIN	ØH MAX	C ±0,5	D MAX	E MAX	F MAX	K ±0,5	RECOMMENDED BOOT SIZE
08	7/16-28 UNEF	18,3	6,6	13,5	16,4	17,6	22,7	25,5	15,0	202 K 121
10	9/16-24 UNEF	21,5	10,1	15,4	17,2	18,4	26,2	27,3	17,0	202 K 121
12	11/16-24 UNEF	24,5	12,9	19,7	17,6	19,3	29,2	28,7	18,0	202 K 142
14	13/16-20 UNEF	27,8	16,1	21,3	18,5	19,6	32,2	30,2	20,0	202 K 142
16	15/16-20 UNEF	30,8	19,3	24,5	19,2	20,4	35,7	31,9	21,5	202 K 153
18	1 1/16-18 UNEF	34,1	21,7	26,5	19,6	20,8	39,7	33,5	23,0	202 K 153
20	1 3/16-18 UNEF	37,3	24,9	31,0	20,4	21,6	42,2	35,1	25,0	202 K 153
22	1 5/16-18 UNEF	40,5	28,1	34,4	20,8	22,5	45,2	36,7	26,0	202 K 163
24	1 7/16-18 UNEF	43,7	31,3	36,6	21,7	22,9	48,2	38,1	28,0	202 K 163

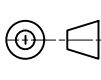
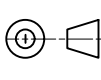

TABLE 2

CODE	FINISH
C	ELECTROLESS NICKEL
B	CADMIUM OLIVE DRAB OVER ELECTROLESS NICKEL
ZB	ZINC COBALT OLIVE DRAB OVER ELECTROLESS NICKEL
ZN	ZINC NICKEL BLACK PASSIVATE OVER ELECTROLESS NICKEL
G	BLACK ANODISE, SULPHURIC

LIST NOT EXHAUSTIVE, SEE PLATING TABLE FOR OTHER OPTIONS

97F1-16-1-C-L30

SERIES _____
 CONNECTOR INTERFACE _____
 ANGLE _____
 SHELL SIZE (TABLE 1) _____
 MATERIAL _____
 ALUMINIUM ALLOY
 FINISH (TABLE 2) _____
 LENGTH CODE IN mm (STRAIGHT ONLY) _____
 OMIT FOR STANDARD 20,50mm

DRAWN	J.CLARK	DATE 23/02/2009	 3RD ANGLE PROJECTION NOT TO SCALE	 POLAMCO LTD WESTON LOCK LOWER BRISTOL ROAD BATH BA2 1EP	PAGE 2	UNLESS OTHERWISE SPECIFIED ALL DIMENSIONS IN MILLIMETRES
SALES APPR						
DESIGN APPR			THIS DRAWING IS COPYRIGHT AND THE PROPERTY OF POLAMCO LTD IT MUST NOT BE COPIED, USED FOR MANUFACTURE OR OTHERWISE DISCLOSED WITHOUT PRIOR WRITTEN CONSENT OF THE COMPANY.	ASSY USED ON: MIL-DTL-38999 SERIES II	MATERIAL ALUMINIUM ALLOY	NCAGE CODE U5792
QUAL APPR						
ISSUE 6	DCR 6245					
WEIGHT	GENERAL TOL LINEAR +/-0.1MM ANGULAR +/- 1°		PART NUMBER: 97F SERIES			