

REVISIONS				
REV	DESCRIPTION	DATE	CHANGED BY	APPROVED BY
AB	ECR 8137	22/03/2021	D. WRIGLEY	R. STYLES

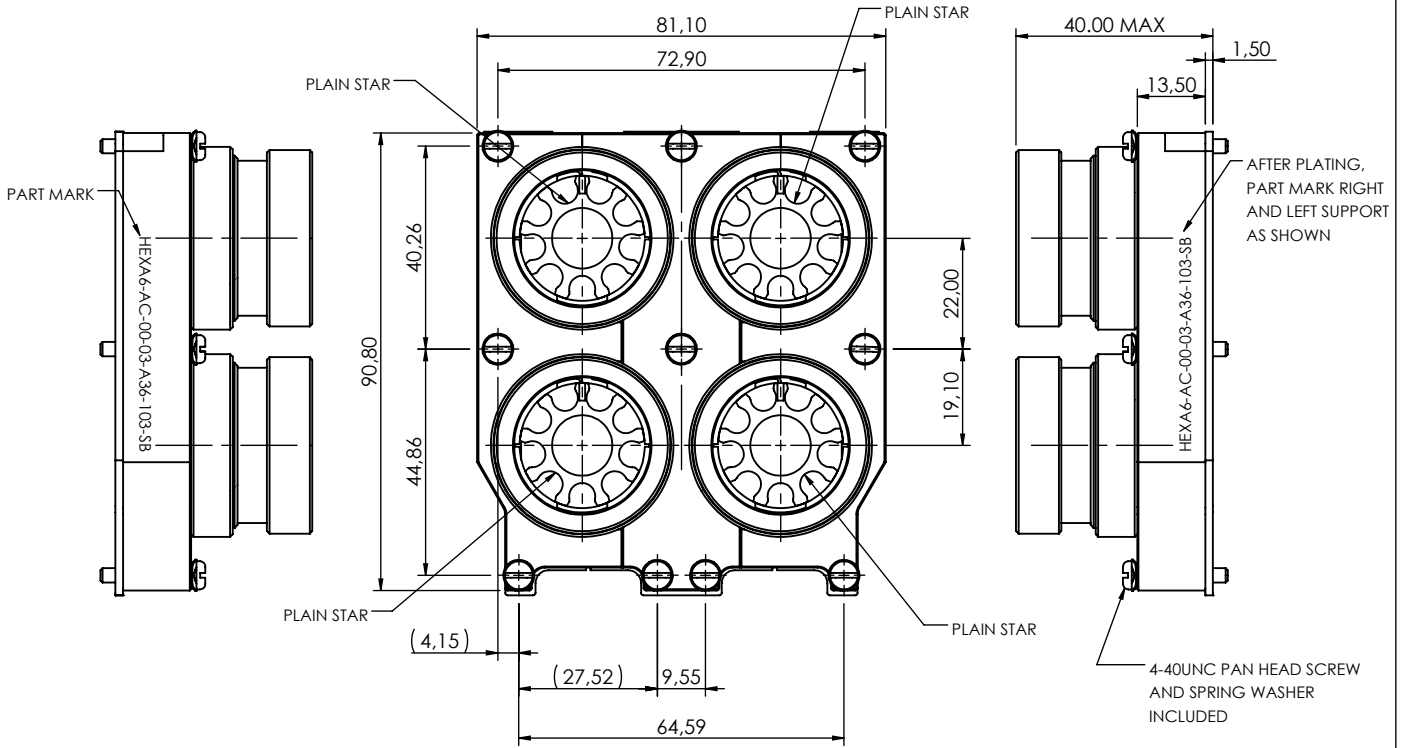
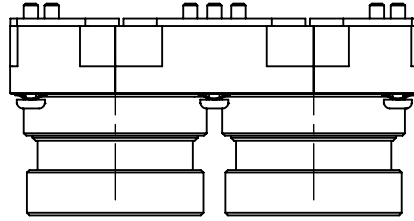
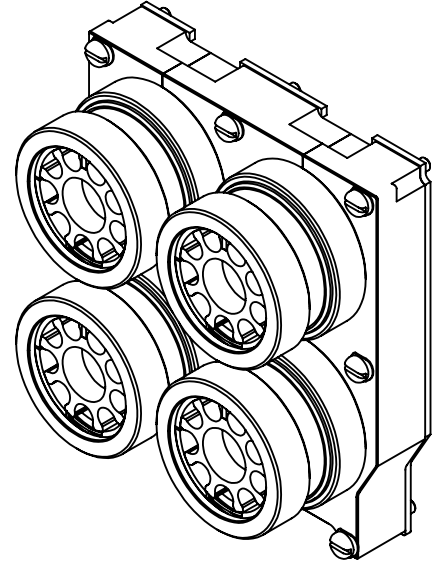

THIS DRAWING IS UNPUBLISHED. ALL RIGHTS RESERVED. © COPYRIGHT 20 BY

DIMENSIONS: MILLIMETERS	DWN: D. WRIGLEY 19/07/2018	MATERIAL: SEE SS0076	FINISH: SEE SS0076
	CHK: -	TE Connectivity	
TOLERANCES UNLESS OTHERWISE SPECIFIED: GENERAL TOL LINEAR ±0.25MM ANGULAR ±1°	APVD: M. PAUL 19/07/2018		
	PRODUCT SPEC: -	NAME: ARINC 600 SIZE 3 - 4 OUTLET ASSEMBLY	
	APPLICATION SPEC: -	SIZE: A4	CAGE CODE: U5792
	WEIGHT: SEE NOTE 2	DRAWING NO: C-P36931	RESTRICTED TO
	CUSTOMER DRAWING	SCALE: 1:1.5	SHEET: 1 OF 3 REV: AB

REVISIONS

REV	DESCRIPTION	DATE	CHANGED BY	APPROVED BY
AB	ECR 8137	22/03/2021	D. WRIGLEY	R. STYLES

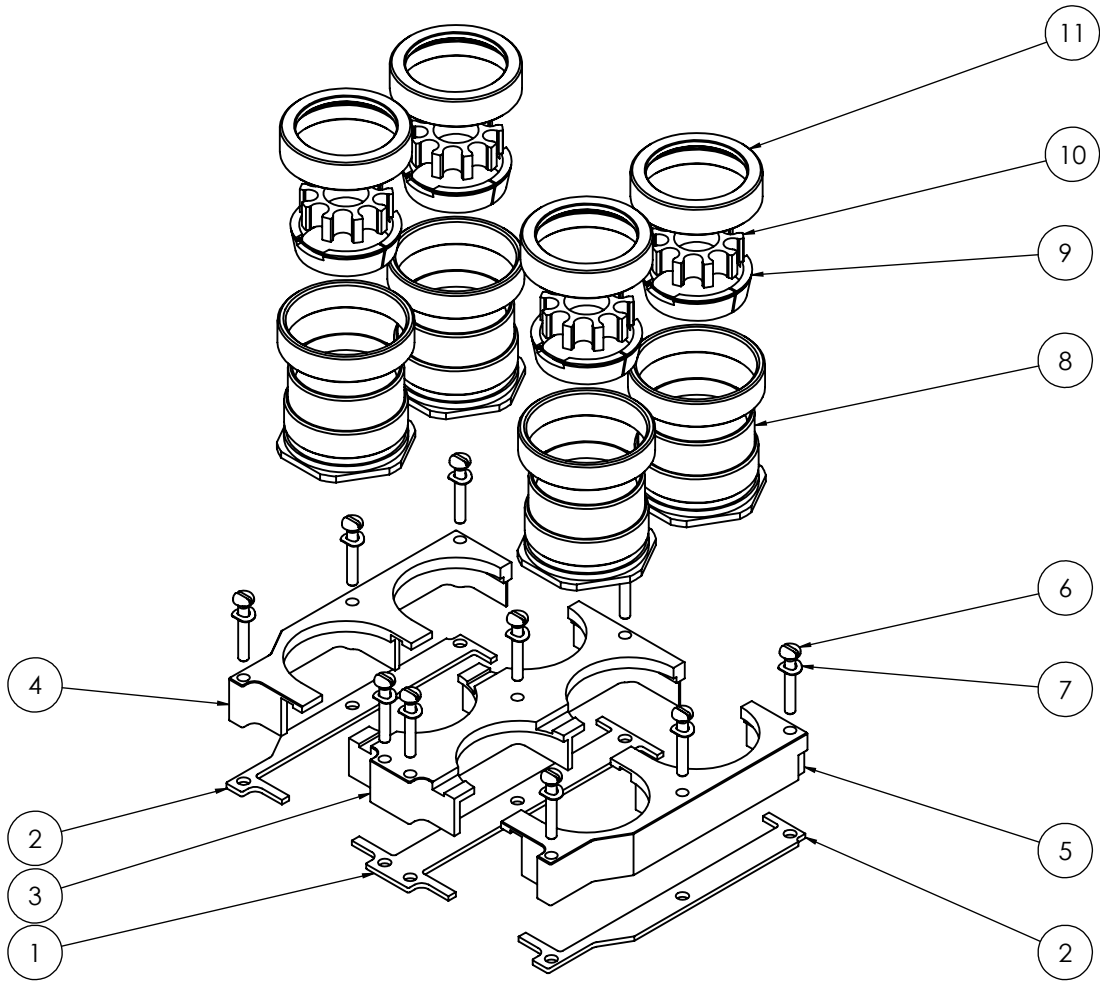

ITEM	QTY	DESCRIPTION	MATERIAL
1	1	RETAINER PLATE	ALUMINIUM ALLOY
2	2	RETAINER PLATE	ALUMINIUM ALLOY
3	1	CENTRE SUPPORT	ALUMINIUM ALLOY
4	1	LEFT HAND SUPPORT	ALUMINIUM ALLOY
5	1	RIGHT HAND SUPPORT	ALUMINIUM ALLOY
6	10	4-40UNC PAN HEAD SCREW 3/4" LONG	STAINLESS STEEL - PASSIVATED
7	10	SPRING WASHER	STAINLESS STEEL - PASSIVATED
8	4	OUTLET ASSEMBLY - M33	STAINLESS STEEL - PASSIVATED
9	4	CONIC RING ASSEMBLY	ALUMINIUM ALLOY
10	4	PLAIN STAR	ALUMINIUM ALLOY
11	4	BACK NUT	ALUMINIUM ALLOY

RELEASED FOR PUBLICATION

ALL RIGHTS RESERVED.

THIS DRAWING IS UNPUBLISHED.

© COPYRIGHT 20 BY

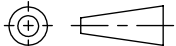
DIMENSIONS: MILLIMETERS	DWN: D. WRIGLEY 19/07/2018	MATERIAL: SEE SS0076	FINISH: SEE SS0076
	CHK: -	 TE Connectivity	
TOLERANCES UNLESS OTHERWISE SPECIFIED:	APVD: M. PAUL 19/07/2018		
GENERAL TOL LINEAR ± 0.25 MM ANGULAR $\pm 1^\circ$	PRODUCT SPEC: -	NAME: ARINC 600 SIZE 3 - 4 OUTLET ASSEMBLY	
	APPLICATION SPEC: -	SIZE: A4	CAGE CODE: U5792
	WEIGHT: SEE NOTE 2	DRAWING NO: C-P36931	RESTRICTED TO
	CUSTOMER DRAWING	SCALE: 1:2	SHEET: 2 OF 3
		REV: AB	

REVISIONS				
REV	DESCRIPTION	DATE	CHANGED BY	APPROVED BY
AB	ECR 8137	22/03/2021	D. WRIGLEY	R. STYLES

HEXA6 - A C - 00 - 03 - A36 - 103 - SB

CONNECTOR CODE NUMBER _____
 HEXA6 = ARINC 600 CONNECTOR

MATERIAL CODE _____
 ALUMINIUM ALLOY

PLATING CODE _____
 B = CADMIUM OLIVE DRAB TO SAE-AMS-QQ-P-416
 C = ELECTROLESS NICKEL TO SAE-AMS-MIL-C-26074

OUTLET STYLE _____
 00 = STRAIGHT

SHELL SIZE _____
 03 = SIZE 3

ORDER NUMBER _____
 A36 = 36 FERRULE HEXASHIELD TERMINATION

ASSEMBLY SPECIFICATION ORDER NUMBER (CUSTOMER MODIFICATION) _____
 SB (MODIFIED SIDE SUPPORT)

APPLICATION

THIS BACKSHELL ASSEMBLY IS DESIGNED TO BE MOUNTED ON THE FOLLOWING CONNECTORS:
 ARINC 600 PLUG, SHELL SIZE 3. RETAINER PLATES RETAIN INSERTS IN CAVITIES A, B, D AND E.

PACKAGING

ALL ASSEMBLIES ARE SUPPLIED BOXED AND LABELLED.

NOTES.

- ASSEMBLY IS TO BE PERMANENTLY MARKED WITH CODE IDENTITY NUMBER AND PART NUMBER IN THE POSITION SHOWN ON SHEET 1. (E.G. U5792 HEXA6-AC-00-03-A36-103-SB)
- ESTIMATED WEIGHT: APPROXIMATELY 225g

RELEASED FOR PUBLICATION

ALL RIGHTS RESERVED.

THIS DRAWING IS UNPUBLISHED.

© COPYRIGHT 20 BY

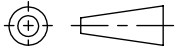
DIMENSIONS: MILLIMETERS	DWN: D. WRIGLEY 19/07/2018	MATERIAL: SEE SS0076	FINISH: SEE SS0076
	CHK: -	 TE Connectivity	
TOLERANCES UNLESS OTHERWISE SPECIFIED:	APVD: M. PAUL 19/07/2018	PART NUMBER: HEXA6-xx-00-03-A36-103-SB	
GENERAL TOL LINEAR ±0.25MM ANGULAR ±1°	PRODUCT SPEC: -	NAME: ARINC 600 SIZE 3 - 4 OUTLET ASSEMBLY	
	APPLICATION SPEC: -	SIZE: A4	CAGE CODE: U5792
	WEIGHT: SEE NOTE 2	DRAWING NO: C-P36931	RESTRICTED TO
	CUSTOMER DRAWING	SCALE: 1:1.5	SHEET: 3 OF 3 REV: AB