

REVISIONS

P	LTR	DESCRIPTION	DATE	DWN	APVD
	A	INITIAL	20AUG2016	YC	CW
	B	ECR-20-007782	24NOV2020	BS	CW

NOTES:

- 1. TECHNICAL CHARACTERISTICS:
 BODY MATERIAL: DIE CAST ZINC ALLOY
 SURFACE TREATMENT: NICKEL PLATED
 SEAL MATERIAL: EPDM
 DEGREE OF PROTECTION: IP65 (MATED)

注释:

- 1. 技术参数:
 主体材料: 锌合金
 表面处理: 镀镍
 密封材料: EPDM
 防护等级: IP65(配合)

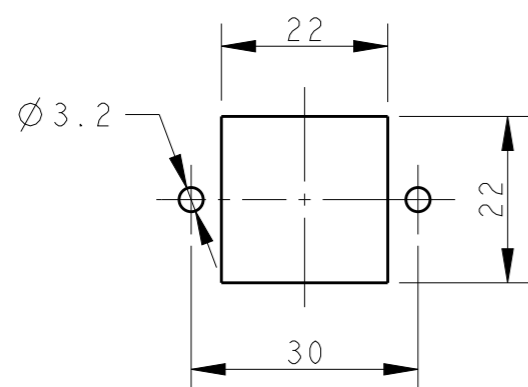
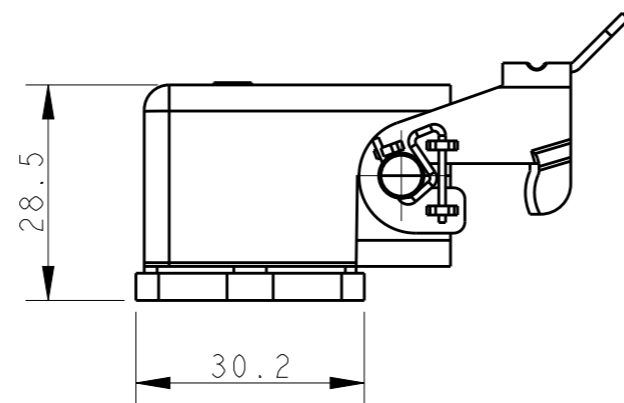
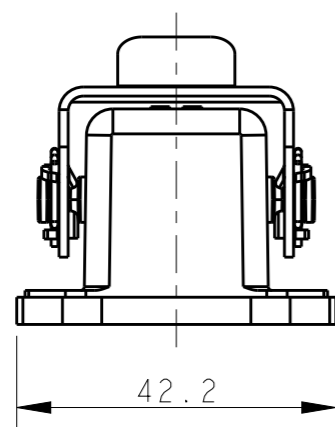
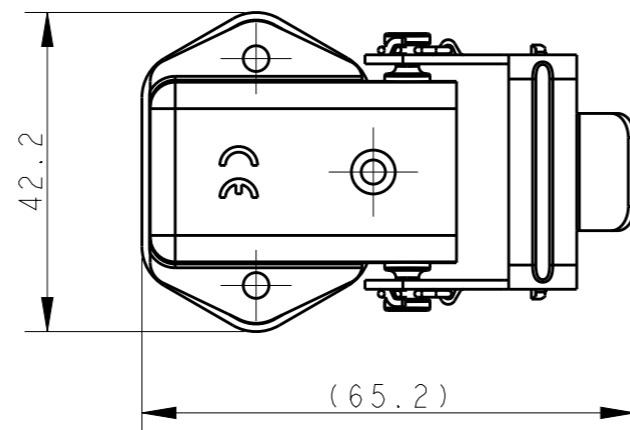
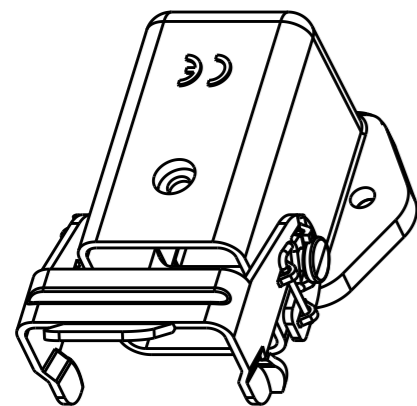

PANEL CUT OUT
面板开孔尺寸

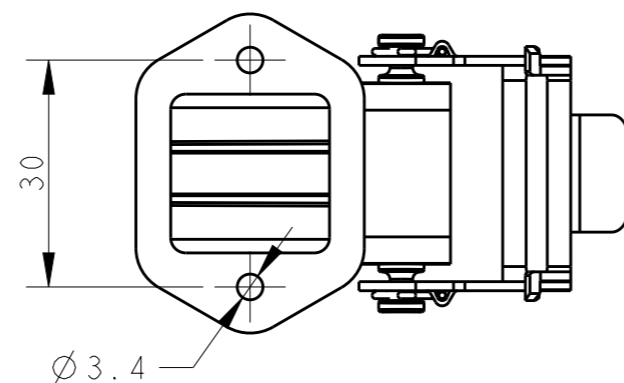

T1546033000-000	H3A-MAGS-EMC	H3A EMC HOUSING, BULKHEAD MOUNTED, SIDE ENTRY, SINGLE STEEL LOCKING WITH ZINC PLATED, NICKEL PLATED H3A 带屏蔽下壳, 开孔侧出, 彩锌单扣, 镀镍
PART NUMBER 料号	PART DESCRIPTION 描述	

THIS DRAWING IS A CONTROLLED DOCUMENT.		DWN 20AUG2016 YORK CHEN	 TE Connectivity	
DIMENSIONS: mm		CHK 20AUG2016 KYLE ZENG		
TOLERANCES UNLESS OTHERWISE SPECIFIED:		APVD 20AUG2016 CHRIS WANG	NAME H3A-MAGS-EMC	
0 PLC ±-		PRODUCT SPEC 108-137012	SIZE	
1 PLC ±-		APPLICATION SPEC 114-137012	CAGE CODE	
2 PLC ±-		WEIGHT	DRAWING NO	
3 PLC ±-		Customer Drawing	A300779	
4 PLC ±-			C-T1546033000000	
ANGLES ±-			RESTRICTED TO	
FINISH			SCALE 1:1	
			SHEET 1 OF 1	
			REV B	