

REVISIONS

P	LTR	DESCRIPTION	DATE	DWN	APVD
	A	INITIAL	28DEC2016	CH	CW

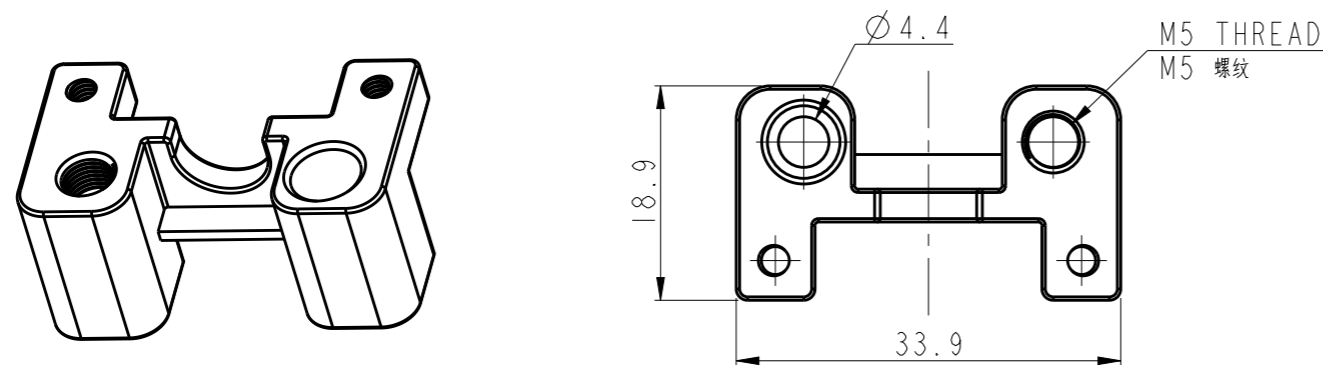

TYPE 1: MOUNTING BRACKET, COLOR ZINC PLATED
 类型1: 固定架, 镀彩锌

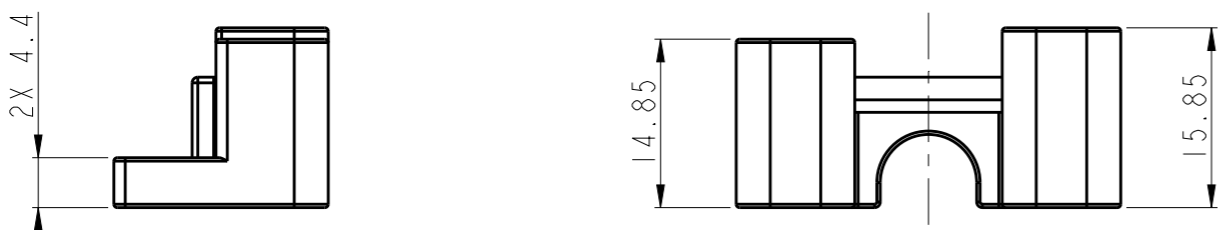
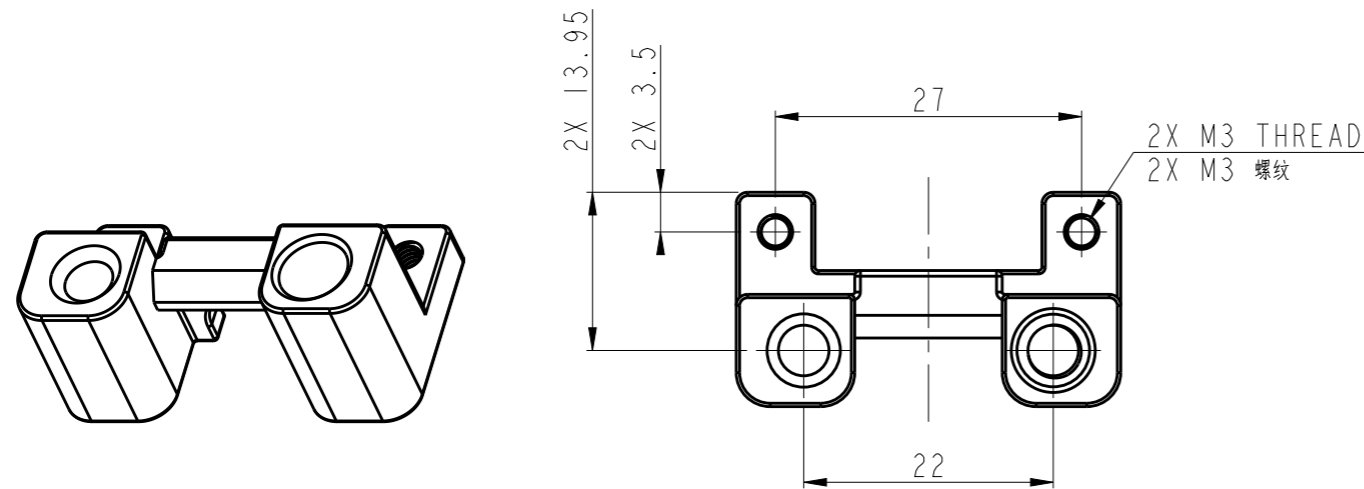
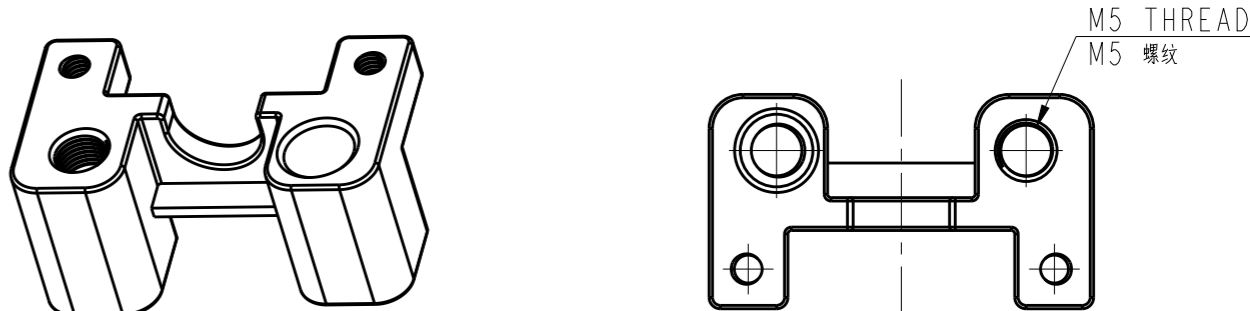
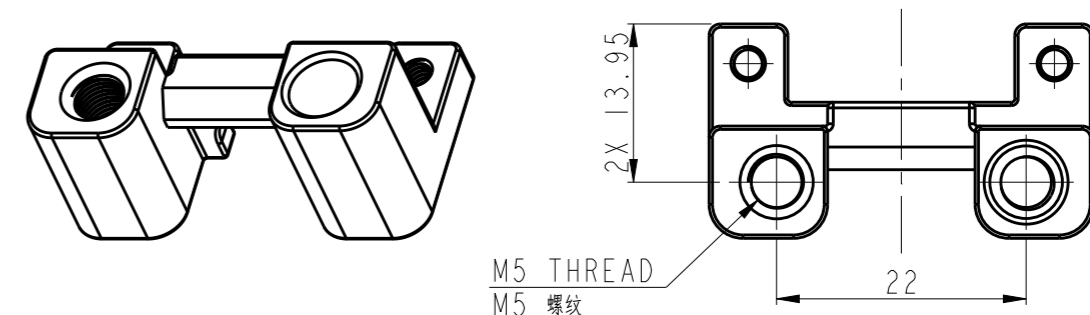

TYPE 2: MOUNTING BRACKET B, COLOR ZINC PLATED
 ALL DIMENSIONS ARE SAME AS TYPE 1,
 EXCEPT SCREW HOLES DEFINED IN THIS TYPE.
 类型2: 固定架B, 镀彩锌
 除了在本类型中定义的螺丝孔外, 其它尺寸同类型1.

NOTES:

- 1. TECHNICAL CHARACTERISTICS:
 MATERIAL: DIE CAST ZINC ALLOY
 SURFACE: COLOR ZINC PLATED

- 注释:
- 1. 技术参数:
 材料: 锌合金
 表面处理: 镀彩锌

THIS DRAWING IS A CONTROLLED DOCUMENT.		DWN CHARLIE.HU 28DEC2016	TE Connectivity NAME HB-GDZ-S/HB-GDZ-B/HB-GDZ-T/HB-GDZ-X	
DIMENSIONS: mm		CHK KYLE.ZENG 28DEC2016		
TOLERANCES UNLESS OTHERWISE SPECIFIED:		APVD CHRIS.WANG 28DEC2016		
0 PLC ±- 1 PLC ±- 2 PLC ±- 3 PLC ±- 4 PLC ±- ANGLES ±-		PRODUCT SPEC -		
MATERIAL		FINISH	APPLICATION SPEC -	SIZE A3
-		-	WEIGHT -	CAGE CODE -
-		-	CUSTOMER DRAWING	DRAWING NO C-TX40312XXXX000
			SCALE 2:1	RESTRICTED TO -
			SHEET 1 OF 3	REV A

REVISIONS

P	LTR	DESCRIPTION	DATE	DWN	APVD
-	-	SEE SHEET 1	-	-	-

NOTES:
SEE SHEET 1

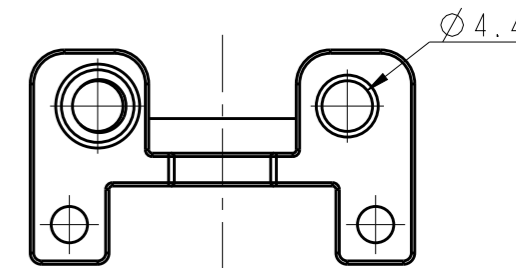
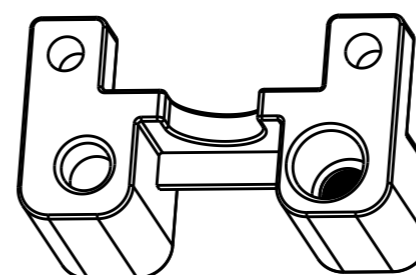
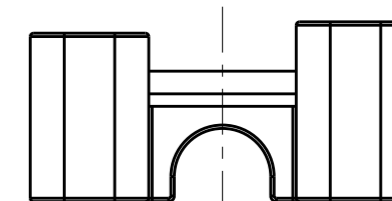
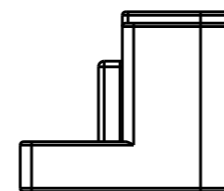
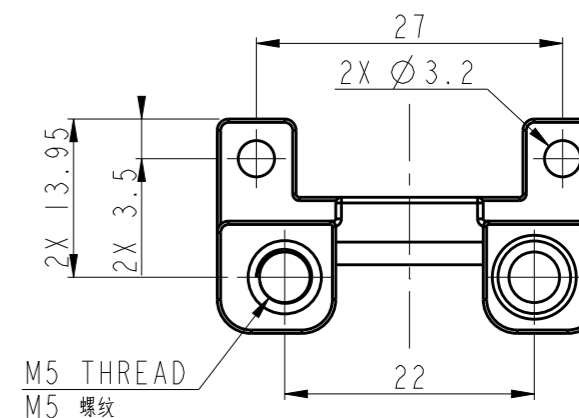
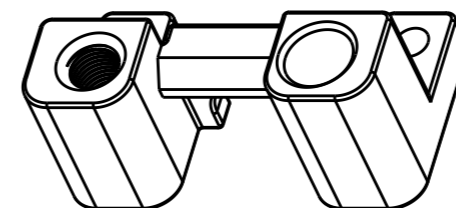
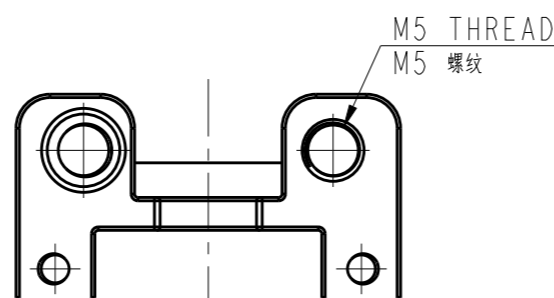
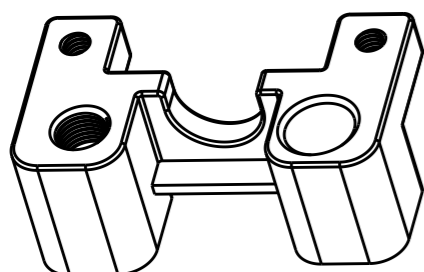
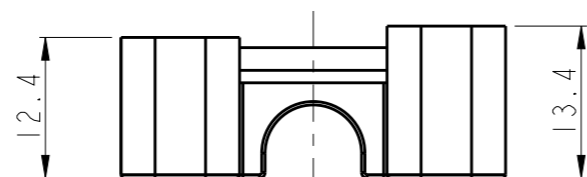
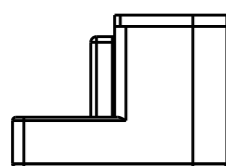
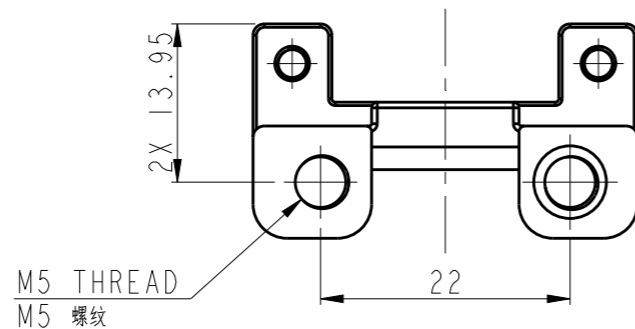
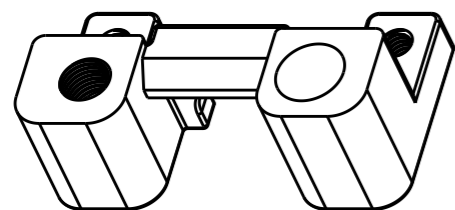

TYPE 3: MOUNTING BRACKET T, COLOR ZINC PLATED
ALL DIMENSIONS ARE SAME AS TYPE 1,
EXCEPT THE FEATURES DEFINED IN THIS TYPE.

类型3: 固定架T, 镀彩锌
除了在本类型中定义的特征外, 其它尺寸同类型1.

TYPE 4: MOUNTING BRACKET BASE, COLOR ZINC PLATED
ALL DIMENSIONS ARE SAME AS TYPE 1,
EXCEPT THE FEATURES DEFINED IN THIS TYPE.

类型4: 固定架座, 镀彩锌
除了在本类型中定义的特征外, 其它尺寸同类型1.

THIS DRAWING IS A CONTROLLED DOCUMENT.

DWN CHARLIE.HU 28DEC2016
 CHK KYLE.ZENG 28DEC2016
 APVD CHRIS.WANG 28DEC2016



DIMENSIONS:
mm

TOLERANCES UNLESS OTHERWISE SPECIFIED:

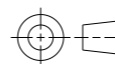

0 PLC ±-
 1 PLC ±-
 2 PLC ±-
 3 PLC ±-
 4 PLC ±-
 ANGLES ±-

MATERIAL

FINISH

PRODUCT SPEC

APPLICATION SPEC

WEIGHT

CUSTOMER DRAWING

NAME
HB-GDZ-S/HB-GDZ-B/HB-GDZ-T/HB-GDZ-X

SIZE	CAGE CODE	DRAWING NO	RESTRICTED TO
------	-----------	------------	---------------

A3	-	TX40312XXXX000	-
----	---	----------------	---

SCALE	SHEET	OF	REV
3:2	2	3	A

THIS DRAWING IS UNPUBLISHED.

RELEASED FOR PUBLICATION 20

© COPYRIGHT 20 BY - ALL RIGHTS RESERVED.

REVISIONS

P	LTR	DESCRIPTION	DATE	DWN	APVD
-		SEE SHEET 1	-	-	-

NOTES:
SEE SHEET 1

T3403122000-000	HB-GDZ-X	MOUNTING BRACKET BASE, COLOR ZINC PLATING 固定架座, 镀彩锌	TYPE 4 类型4
T6403121234-000	HB-GDZ-T	MOUNTING BRACKET T, COLOR ZINC PLATING 固定架T, 镀彩锌	TYPE 3 类型3
T3403122325-000	HB-GDZ-B	MOUNTING BRACKET B, COLOR ZINC PLATING 固定架B, 镀彩锌	TYPE 2 类型2
T3403121000-000	HB-GDZ-S	MOUNTING BRACKET, COLOR ZINC PLATING 固定架, 镀彩锌	TYPE 1 类型1
PART NUMBER 零件料号	PART DESCRIPTION 零件描述		TYPE 类型

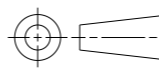
THIS DRAWING IS A CONTROLLED DOCUMENT.		DWN 28DEC2016 CHARLIE.HU	STE TE Connectivity	
		CHK 28DEC2016 KYLE.ZENG		
		APVD 28DEC2016 CHRIS.WANG	NAME HB-GDZ-S/HB-GDZ-B/HB-GDZ-T/HB-GDZ-X	
DIMENSIONS: mm		TOLERANCES UNLESS OTHERWISE SPECIFIED:		PRODUCT SPEC
		0 PLC ±-	APPLICATION SPEC	
		1 PLC ±-	-	
MATERIAL		2 PLC ±-	SIZE	CAGE CODE
		3 PLC ±-	A3	-
		4 PLC ±-	DRAWING NO	
		ANGLES ±-	C-TX40312XXXX000	
FINISH		WEIGHT		RESTRICTED TO
		-		-
		CUSTOMER DRAWING		SCALE 3:2
				SHEET 3 OF 3
				REV A