

Type LR Series

Key Features

IEC Color Coding

Down to 1% Tolerance

Down to 50PPM TCR

6 sizes

Suitable for general purpose or precision applications

Moisture Sensitivity Level: MSL1

Applications

Control circuitry

Turbines

Drives



The resistive element comprises a thin film of nickel-chrome alloy evaporated onto a high thermal conductivity ceramic element. Metal end caps are force fitted to the element prior to spiralling to value. Tinned copper lead wires are welded to the end caps and the components are then coated. One coat of phenolic resin is followed by three coats of epoxy resin. All resistors are tested for value and tolerance.

Characteristics – Electrical

Type	LR0204	LR1L	LR1	LR2	LR100	LR200
Rated Power @ 70°C (W)	0.25	0.5	0.6	0.75	1	2
Resistance Range (Ω)	10 ~ 1M	0.1 ~ 0.82	1 ~ 10M	10 ~ 1M	51.1 ~ 1M	1 ~ 1M
Resistance Tolerance (%)	±1%	±5%	±1%	±1%	±1%	±1%
Max. Working Voltage	200	250	250	350	500	500
Max. Overload Voltage	400	500	500	700	1000	1000
Dielectric Withstand Voltage	400	250	500	700	1000	1000
Operating Temp. Range	-55 ~ 155°C					
Voltage Rating	Max. Working Voltage or $\sqrt{P / R}$ whichever is lesser					
	Max. Overload Voltage or $2.5 \sqrt{P / R}$ whichever is lesser					

Environmental Characteristics

Characteristics	Limits	Test Methods (JIS C 5201-1)
DC. Resistance	Must be within the specified tolerance	5.1 The limit of error of measuring apparatus shall not exceed allowable range or 5% of resistance tolerance
Temperature coefficient	LR0204, LR2, LR100 And LR200: ±100/°C Max.	5.2 Natural resistance change per temp. degree centigrade $\frac{R^2-R^1}{R^1(t^2-t^1)} * 10^6 \quad (\text{PPM}/^\circ\text{C})$ R1: Resistance value at room temperature (t1) R2: Resistance value at room temp. plus 100 °C (t2)
	LR1	
	Resistance Value (Ω) T.C.R (PPM/°C)	
	1 ~ 9.1 ± 100	
	10 ~ 1M ± 50	
1.1M ~ 10M ± 100		
	LR1L: ±200 PPM	
Short time overload	Resistance change rate is ± (0.5% + 0.05Ω) Max. with no evidence of mechanical damage	5.5 Permanent resistance change after the application of a potential of 2.5 times RCWV for 5 seconds
Dielectric withstanding voltage	No evidence of flashover mechanical damage, arcing or insulation break down	5.7 Resistors shall be clamped in the trough of a 90° metallic V-block and shall be tested at AC potential respectively specified in the table 1. for 60 + 10/ -0 seconds
Pulse overload	Resistance change rate is ± (1% + 0.05Ω) Max. with no evidence of mechanical damage	5.8 Resistance change after 10,000 cycles (1 sec. "on", 25 secs. "off") at 4 times RCWV
Terminal strength	No evidence of mechanical damage	6.1 Direct load : Resistance to a 2.5 kgs direct load for 10 secs. in the direction of the longitudinal axis of the terminal leads Twist test : Terminal leads shall be bent through 90 ° at a point of about 6mm from the body of the resistor and shall be rotated through 360° about the original axis of the bent terminal in alternating direction for a total of 3 rotations

Characteristics	Limits		Test Methods (JIS C 5201-1)		
Resistance to soldering heat	Resistance change rate is $\pm (1\% + 0.05\Omega)$ Max. with no evidence of mechanical damage		6.4 Permanent resistance change when leads immersed to 3.2 to 4.8 mm from the body in $350^{\circ}\text{C} \pm 10^{\circ}\text{C}$ solder for 3 ± 0.5 seconds		
Solderability	95 % coverage Min.		6.5 The area covered with a new, smooth, clean, shiny and continuous surface free from concentrated pinholes. Test temp. of solder: $245^{\circ}\text{C} \pm 3^{\circ}\text{C}$ Dwell time in solder : 2 ~ 3 seconds		
Resistance to solvent	No deterioration of protective coatings and markings		6.9 Specimens shall be immersed in bath of trichroethane completely for 3 mins. with ultrasonic		
Temperature cycling	Resistance change rate is $\pm (1\% + 0.05\Omega)$ Max. with no evidence of mechanical damage		7.4 Resistance change after continuous 5 cycles for duty shown below:		
			Step	Temperature	Time
			1	$-55^{\circ}\text{C} \pm 3^{\circ}\text{C}$	30 mins
			2	Room temp.	10~15 mins
			3	$+155^{\circ}\text{C} \pm 2^{\circ}\text{C}$	30 mins
4	Room temp.	10~15 mins			
Load life in humidity			7.9 Resistance change after 1,000 hours (1.5 hours "on", 0.5 hour "off") at RCWV in a humidity test chamber controlled at $40^{\circ}\text{C} \pm 2^{\circ}\text{C}$ and 90 to 95 % relative humidity		
	Resistance Value	$\Delta R/R$			
	Normal type	$\pm 1.5\%$			
	LR1L				
	Non-Flame type	5%			
Load life			7.10 Permanent resistance change after 1,000 hours operating at RCWV with duty cycle of (1.5 hours "on", 0.5 hour "off") at $70^{\circ}\text{C} \pm 2^{\circ}\text{C}$ ambient		
	Resistance Value	$\Delta R/R$			
	Normal type	$\pm 1.5\%$			
	LR1L				
	Non-Flame type	5%			

Derating

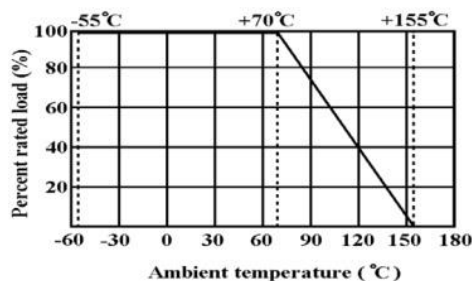

Construction

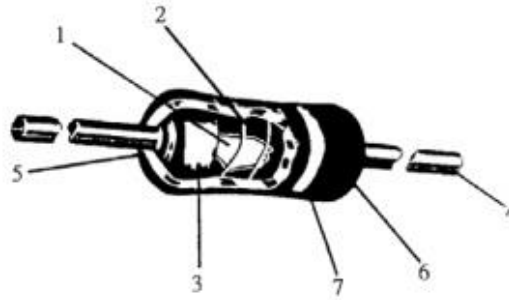

No.	Name	Material
1	Basic Body	Rod Type Ceramics
2	Resistance Film	Resistance Range
		Material
		LR1
1Ω ~ 2.4Ω	Carbon Film	
2.41Ω ~ 10MΩ	Metal Film	
	All Others	Metal Film
3	End Cap	Steel (Tin plated iron surface)
4	Lead Wire	Annealed copper wire coated with tin
5	Joint	By Welding
6	Coating	Insulated epoxy resin (Colour : See Outer Coating)
		LR1L: Insulated & Non-Flame Paint (Colour : See Outer Coating)
7	Colour Code	Epoxy Resin
		LR1L: Non-Flame Paint Epoxy Resin

Dimensions

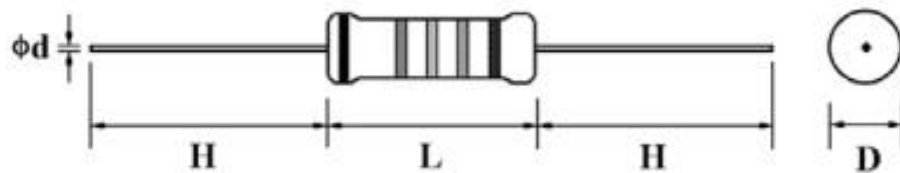

Type	Power Rating (W)	D (Max) (mm)	L (Max) (mm)	d ±0.05 (mm)	H ±3.0 (mm)
LR0204	0.25	2.0	3.4	0.45	28
LR1L	0.5	2.5	6.8	0.54	28
LR1	0.6	2.5	6.8	0.54	28
LR2	0.75	3.5	10	0.54	28
LR100	1.0	5.0	12.0	0.70	25
LR200	2.0	5.5	16.0	0.70	28

Outer Coating

Welding point, terminal and lead wire, is permissible to be exposed without the outer coated cover. The extent should be within 1/2 of the body Diameter.

Coating Colour

- Green
- LR0204, LR1L (dark green)
- Blue
- LR1, LR2, LR100, LR200

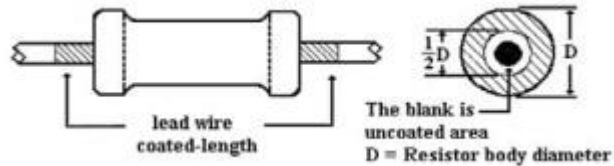

Marking

Resistors shall be marked with colour coding in accordance with JIS C 0802

LR1L Type	<p style="text-align: center;">LR1L Type (4 Band)</p> <table border="1"> <thead> <tr> <th></th> <th>First Digit</th> <th>Second Digit</th> <th>Multiplier</th> <th>Tolerance</th> </tr> </thead> <tbody> <tr><td>Black</td><td>Nil</td><td>0</td><td>1</td><td>Nil</td></tr> <tr><td>Brown</td><td>1</td><td>1</td><td>10</td><td>±1%</td></tr> <tr><td>Red</td><td>2</td><td>2</td><td>100</td><td>±2%</td></tr> <tr><td>Orange</td><td>3</td><td>3</td><td>1000</td><td>±3%</td></tr> <tr><td>Yellow</td><td>4</td><td>4</td><td>10000</td><td>±4%</td></tr> <tr><td>Green</td><td>5</td><td>5</td><td>100000</td><td>±0.5%</td></tr> <tr><td>Blue</td><td>6</td><td>6</td><td>1M</td><td>±0.25%</td></tr> <tr><td>Violet</td><td>7</td><td>7</td><td>10M</td><td>±0.10%</td></tr> <tr><td>Grey</td><td>8</td><td>8</td><td>100M</td><td>±0.05%</td></tr> <tr><td>White</td><td>9</td><td>9</td><td>1G</td><td>Nil</td></tr> <tr><td>Gold</td><td>Nil</td><td>Nil</td><td>÷10</td><td>±5%</td></tr> <tr><td>Silver</td><td>Nil</td><td>Nil</td><td>÷100</td><td>±10%</td></tr> </tbody> </table>		First Digit	Second Digit	Multiplier	Tolerance	Black	Nil	0	1	Nil	Brown	1	1	10	±1%	Red	2	2	100	±2%	Orange	3	3	1000	±3%	Yellow	4	4	10000	±4%	Green	5	5	100000	±0.5%	Blue	6	6	1M	±0.25%	Violet	7	7	10M	±0.10%	Grey	8	8	100M	±0.05%	White	9	9	1G	Nil	Gold	Nil	Nil	÷10	±5%	Silver	Nil	Nil	÷100	±10%													
	First Digit	Second Digit	Multiplier	Tolerance																																																																											
Black	Nil	0	1	Nil																																																																											
Brown	1	1	10	±1%																																																																											
Red	2	2	100	±2%																																																																											
Orange	3	3	1000	±3%																																																																											
Yellow	4	4	10000	±4%																																																																											
Green	5	5	100000	±0.5%																																																																											
Blue	6	6	1M	±0.25%																																																																											
Violet	7	7	10M	±0.10%																																																																											
Grey	8	8	100M	±0.05%																																																																											
White	9	9	1G	Nil																																																																											
Gold	Nil	Nil	÷10	±5%																																																																											
Silver	Nil	Nil	÷100	±10%																																																																											
Other Types	<p style="text-align: center;">Other Types (5 Band)</p> <table border="1"> <thead> <tr> <th></th> <th>First Digit</th> <th>Second Digit</th> <th>Third Digit</th> <th>Multiplier</th> <th>Tolerance</th> </tr> </thead> <tbody> <tr><td>Black</td><td>Nil</td><td>0</td><td>0</td><td>1</td><td>Nil</td></tr> <tr><td>Brown</td><td>1</td><td>1</td><td>1</td><td>10</td><td>±1%</td></tr> <tr><td>Red</td><td>2</td><td>2</td><td>2</td><td>100</td><td>±2%</td></tr> <tr><td>Orange</td><td>3</td><td>3</td><td>3</td><td>1000</td><td>±3%</td></tr> <tr><td>Yellow</td><td>4</td><td>4</td><td>4</td><td>10000</td><td>±4%</td></tr> <tr><td>Green</td><td>5</td><td>5</td><td>5</td><td>100000</td><td>±0.5%</td></tr> <tr><td>Blue</td><td>6</td><td>6</td><td>6</td><td>1M</td><td>±0.25%</td></tr> <tr><td>Violet</td><td>7</td><td>7</td><td>7</td><td>10M</td><td>±0.10%</td></tr> <tr><td>Grey</td><td>8</td><td>8</td><td>8</td><td>100M</td><td>±0.05%</td></tr> <tr><td>White</td><td>9</td><td>9</td><td>9</td><td>1G</td><td>Nil</td></tr> <tr><td>Gold</td><td>Nil</td><td>Nil</td><td>Nil</td><td>÷10</td><td>±5%</td></tr> <tr><td>Silver</td><td>Nil</td><td>Nil</td><td>Nil</td><td>÷100</td><td>±10%</td></tr> </tbody> </table>		First Digit	Second Digit	Third Digit	Multiplier	Tolerance	Black	Nil	0	0	1	Nil	Brown	1	1	1	10	±1%	Red	2	2	2	100	±2%	Orange	3	3	3	1000	±3%	Yellow	4	4	4	10000	±4%	Green	5	5	5	100000	±0.5%	Blue	6	6	6	1M	±0.25%	Violet	7	7	7	10M	±0.10%	Grey	8	8	8	100M	±0.05%	White	9	9	9	1G	Nil	Gold	Nil	Nil	Nil	÷10	±5%	Silver	Nil	Nil	Nil	÷100	±10%
	First Digit	Second Digit	Third Digit	Multiplier	Tolerance																																																																										
Black	Nil	0	0	1	Nil																																																																										
Brown	1	1	1	10	±1%																																																																										
Red	2	2	2	100	±2%																																																																										
Orange	3	3	3	1000	±3%																																																																										
Yellow	4	4	4	10000	±4%																																																																										
Green	5	5	5	100000	±0.5%																																																																										
Blue	6	6	6	1M	±0.25%																																																																										
Violet	7	7	7	10M	±0.10%																																																																										
Grey	8	8	8	100M	±0.05%																																																																										
White	9	9	9	1G	Nil																																																																										
Gold	Nil	Nil	Nil	÷10	±5%																																																																										
Silver	Nil	Nil	Nil	÷100	±10%																																																																										

Soldering Conditions

Characteristics	Limits	Soldering Condition
Soldering Temp. reference	Electrical characteristics shall be satisfied. Without distinct deformation in appearance. (95 % coverage Min.)	The leads immersed into solder bath to 3.2 to 4.8 mm. from the body. Permanent resistance change shall be checked. <u>Wave soldering condition:</u> Pre-heat: 100 to 105 °C, 30 ± 5 sec. Temperature: 245 +10/-0°C, 5 +1/-0sec. <u>Hand soldering condition:</u> Hand soldering Bit temperature: 380 ± 10°C Dwell time in solder: 3 +1/-0sec.
Solderability	95 % coverage Min.	Test temperature of solder: 235-260 °C Dwell time in solder: 3 - 5 seconds

Packaging Taping dimensions

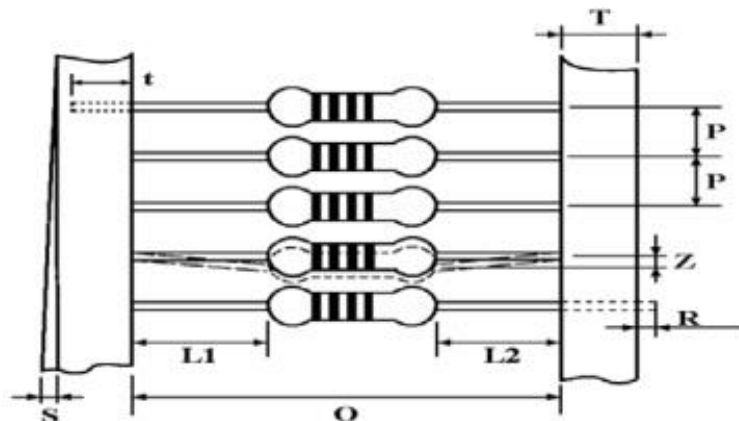

Type	Style	O	P	L1-L2	T	Z	R	T	S
LR0204	PT-52	52 ± 1	5 ± 0.3	1 Max.	6 ± 1	1 Max.	0	4 ± 1	0.5 Max.
LR1L	PT-52	52 ± 1	5 ± 0.3	1 Max.	6 ± 1	1 Max.	0	4 ± 1	0.5 Max.
LR1	PT-52	52 ± 1	5 ± 0.3	1 Max.	6 ± 1	1 Max.	0	4 ± 1	0.5 Max.
LR2	PT-52	52 ± 1	5 ± 0.3	1 Max.	6 ± 1	1 Max.	0	4 ± 1	0.5 Max.
LR100	PT-52	52 ± 1	5 ± 0.3	1 Max.	6 ± 1	1 Max.	0	4 ± 1	0.5 Max.
LR200	PR-52	52 ± 1	5 ± 0.3	1 Max.	6 ± 1	1 Max.	0	4 ± 1	0.5 Max.

Tape in Box Packing

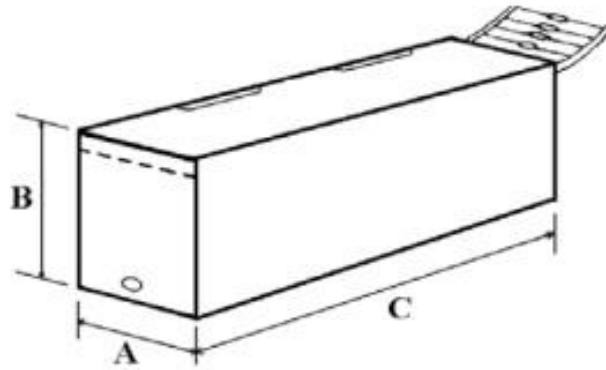

Type	Style	L (C) ±5	W (A) ±5	H (B) ±5	Quantity per box (pcs)
LR0204	PT52	250	75	66	5000
LR1L	PT52	250	75	96	5000
LR1	PT52	250	75	96	5000
LR2	PT52	255	75	43	1000
LR100	PT52	255	79	73	1000
LR200	PT52	255	79	73	1000

Tape on Reel Packing

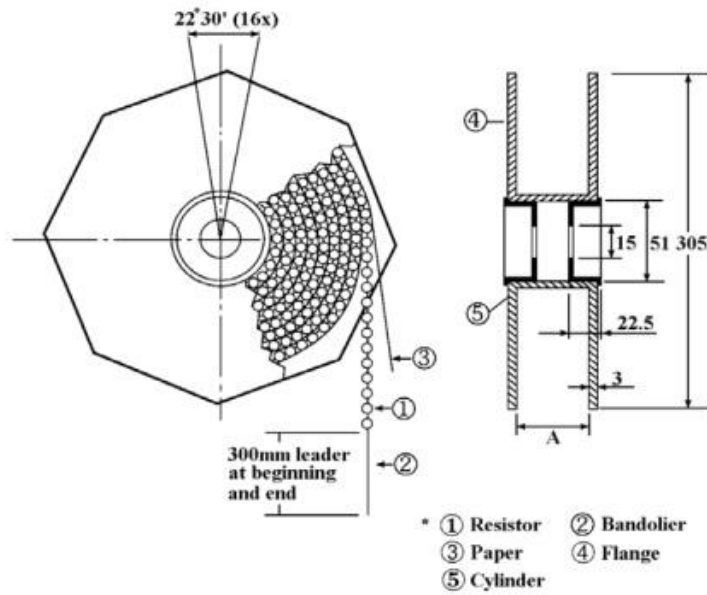

Type	Style	Across Flange (A) (mm)	Quantity Per Reel (Pcs)
LR0204	PT-52	73 ±2	5000
LR1L	PT-52	73 ±2	5000
LR1	PT-52	73 ±2	5000
LR2	PT-52	73 ±2	2500
LR100	PT-52	73 ±2	2500
LR200	PT-52	73 ±2	2500

Environment Related Substance

This product complies to EU RoHS directive, EU PAHs directive, EU PFOS directive and Halogen free.

Ozone layer depleting substances.

Ozone depleting substances are not used in our manufacturing process of this product.

This product is not manufactured using Chloro fluorocarbons (CFCs), Hydrochlorofluorocarbons (HCFCs), Hydrobromofluorocarbons (HBFCs) or other ozone depleting substances in any phase of the manufacturing process.

Storage Condition (MSL1)

The performance of these products, including the solderability, is guaranteed for a year from the date of arrival at your company, provided that they remain packed as they were when delivered and stored at a temperature of $25^{\circ}\text{C} \pm 5^{\circ}\text{C}$ and a relative humidity of $60\%RH \pm 10\%RH$

Even within the above guarantee periods, do not store these products in the following conditions. Otherwise, their electrical performance and/or solderability may be deteriorated, and the packaging materials (e.g. taping materials) may be deformed or deteriorated, resulting in mounting failures.

1. In salty air or in air with a high concentration of corrosive gas, such as Cl_2 , H_2S , NH_3 , SO_2 , or NO_2
2. In direct sunlight

How To Order

LR	1	F	22K	
Common Part	Type	Tolerance	Value	Packing
LR – Metal Film Resistor	0204 – 0.25W 1L – 0.5W 1 – 0.6W 2 – 0.75W 100 – 1W 200 – 2W	F – 1%	100R - 100Ω 1K0 - 1000Ω 100K – 100,000Ω (100KΩ)	Blank - Tape in Box TR – Taped and Reeled

While TE has made every reasonable effort to ensure the accuracy of the information in this data sheet, TE does not guarantee that it is error-free, nor does TE make any other representation, warranty or guarantee that the information is accurate, correct, reliable or current. TE reserves the right to make any adjustments to the information contained herein at any time without notice. TE expressly disclaims all implied warranties regarding the information contained herein, including, but not limited to, any implied warranties of merchantability or fitness for a particular purpose. The dimensions in this data sheet are for reference purposes only and are subject to change without notice. Specifications are subject to change without notice. Consult TE for the latest dimensions and design specifications