

REVISIONS

REV.	ECO	DESCRIPTION	DATE	APPROVED
C	32224	FIND NOS 13 & 14 ADDED	10MAR1997	RS

BR-301G-4
 CONTACTOR-3PST N.O.
 350 AMP 120/208 V 60 HZ

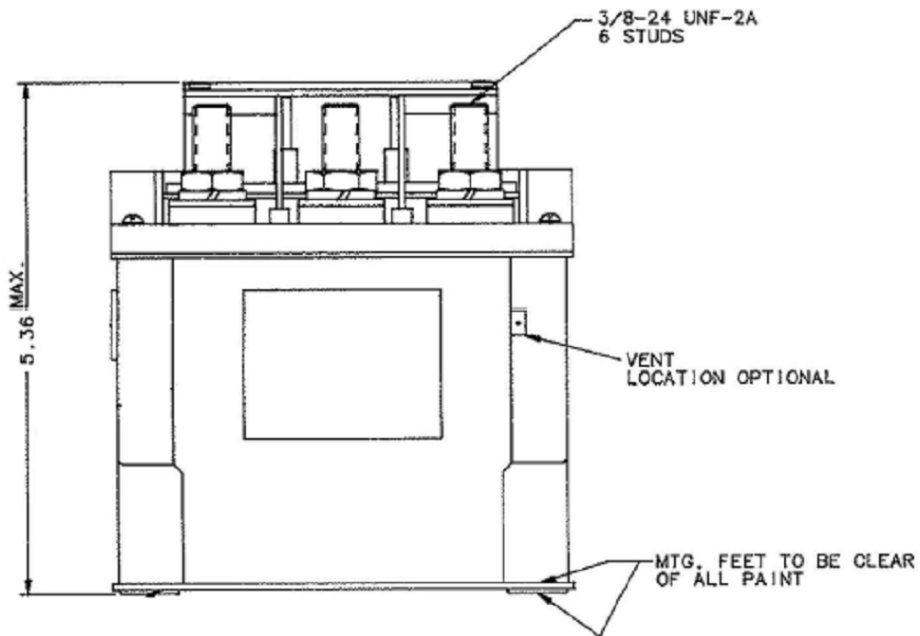
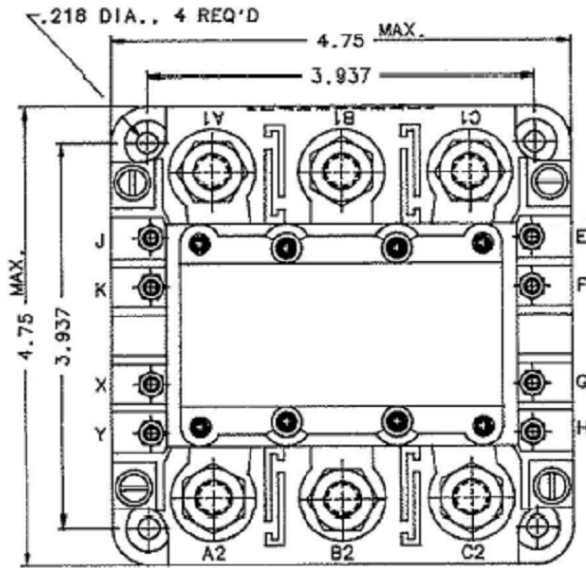

ALL DIMENSIONS ARE IN INCHES



TE CONNECTIVITY
 175 N. DIAMOND STREET MANSFIELD,
 OHIO 44902

TITLE

CONTACTOR-3PST N.O.
 350 AMP 120/208 V 60 HZ

TE P.N.

5-1616105-4

DWG NO.

BR-301G-4

DS DATA SHEET

CAGE CODE
 74063

SCALE
 NONE

SHEET
 1 OF 2

REV
 C

GENERAL SPECIFICATION

CONSTRUCTION	GASKET SEALED	
MAIN CONTACTS	3PST NO DOUBLE BREAK	
CONFIGURATION	120/208 V.	270/480 V.
VOLTAGE (NOMINAL)	50, 60, OR 400 HZ	50, 60, OR 400 HZ
CURRENT RES.	350 AMP.	100 AMP. MAX.
MOTOR	350 AMP.	100 AMP.
RUPTURE	3500 AMP.	1000 AMP.
AUXILIARY CONTACTS	2PDT	
CONFIGURATION	115 VAC. 50, 60, OR 400 HZ/28 VDC.	
VOLTAGE	5 AMP.	
CURRENT RES.		
COIL DATA	CONTINUOUS, ECONOMIZING	
DUTY CYCLE	115 VAC. 50, 60, OR 400 HZ	
NOM. OPERATE VOLTAGE	.7 AMP MAX.	
CURRENT: INRUSH	.2 AMP MAX.	
HOLD	90 VAC	
PICKUP MAX.	40 ± 25 VAC	
DROPOUT VOLTAGE	100 MILLISEC.	
PICKUP TIME MAX.	100 MILLISEC.	
DROPOUT TIME MAX.		
ENVIRONMENTAL DATA	-55°C TO +71°C	
OPERATE TEMP	30,000 CYCLES MIN.	
LIFE ELECTRICAL	50,000 CYCLES MIN.	
LIFE MECHANICAL	8 LBS.	
WEIGHT		

SCHEMATIC

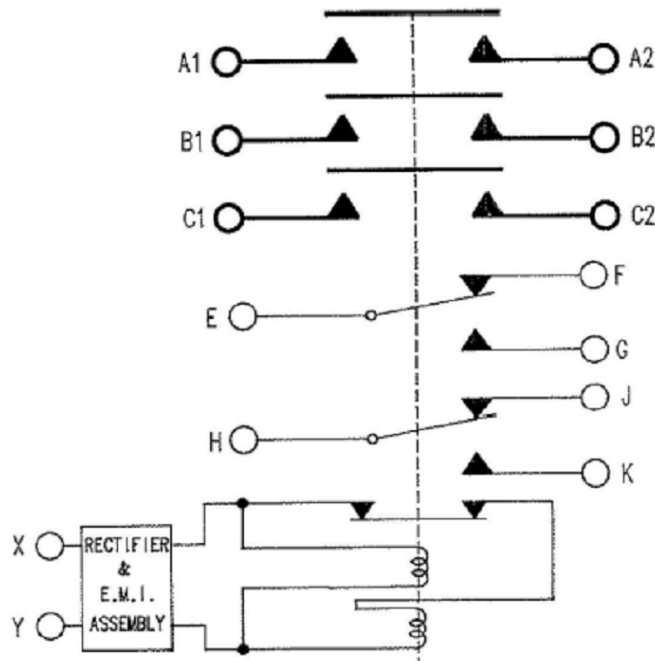

TE CONNECTIVITY
175 N. DIAMOND STREET MANSFIELD,
OHIO 44902

TITLE
CONTACTOR-3PST N.O.
350 AMP 120/208 V 60 HZ

TE P.N.
5-1616105-4

DWG NO.
BR-301G-4

THIRD ANGLE PROJECTION

THIS DRAWING PREPARED
IN ACCORDANCE WITH
ANSI/ASMEY14.5M-1982

CAGE CODE
74063

SCALE
NONE

SHEET
2 OF 2

REV
C