



RACKMOUNT INTELLIGENT PRESSURE SCANNER

NetScanner 9916

PRODUCT DESCRIPTION

TE Connectivity's Rackmount version of its highly successful NetScanner System features the latest generation Model 9916 Rackmount intelligent pressure scanner.

Model 9916 Scanners integrate 16 silicon piezoresistive sensors of any pressure range with a microprocessor. Each field-replaceable pressure sensor incorporates a temperature sensor and an integral EEPROM for storage of personalized calibration data as well as sensor information such as serial number, pressure range, factory calibration date. Integrating the EEPROM within the sensor enables simplified field replacement of sensors with automatic uploading of sensor data during power up.

The microprocessor uses the data from the EEPROM to correct for sensor offset, span, linearity and thermal errors. The microprocessor's digital temperature compensation algorithm reduces sensor thermal errors by a factor of ten or more over conventional sensor compensation. The microprocessor also controls the actuation of an integral manifold to execute on-line zero or span calibrations upon request. This capability virtually eliminates sensor offset drift error and provides system accuracy errors less than $\pm 0.05\%$ FS (Full Scale).

The Model 9916 can sample using up to three concurrent scan lists at continuous rates up to 100 measurements per channel per second in engineering units with timestamps. Pressure data in engineering units is output through an auto-negotiating 10 or 100 Mbit Ethernet interface supporting both TCP and UDP protocols. The Model 9916 data output optionally includes data time stamps derived from either the 9916 internal real time clock, NTP clock or an IEEE 1588-2008 Precision Time Protocol (PTPv2) grand master clock. The scanner is supplied with comprehensive software called NUSS for PC compatible computers. Firmware upgrades are available at no charge and can be downloaded to the scanner over the 9916 Ethernet interface using NUSS.

The Model 9916 intelligent pressure scanner is one component of the NetScanner System. Multiple NetScanner components measuring a wide variety of parameters and sharing the same command set can be networked to form a distributed intelligent data acquisition system.

The Model 9916 replaces the discontinued Model 9816 and features high hardware and software compatibility. The Model 9916 can be used with 98RK and 98RK-1s, and in mixed use with Model 9816s. Specific compatibility is dependent upon customer installation.

FEATURES

- $\pm 0.05\%$ FS System Accuracy
- EU throughput Rates of 100 Hz
- IEEE 1588-2008 PTPv2 & NTP Disciplined Clock
- Scheduled Start of Scanning
- IPv4 and IPv6 Compatible
- Removable Memory
- Hardware Compatible with 98RK and 98RK-1
- Highly Software Compatible with 9816

APPLICATIONS

- Turbine Engine Research
- Turbomachinery Test Cells
- Large Channel Count Pressure Requirements

RACKMOUNT INTELLIGENT PRESSURE SCANNER 9916

NETSCANNER 9916

PERFORMANCE SPECS

*After 1-hour warm-up @ 25°C with atmospheric reference pressures unless otherwise stated / FS = Full Scale

PNEUMATICS

PARAMETER	9916	UNITS	COMMENTS
Pressure Ranges	10 20	In WC	
	1 100 2.5 125 5 150 10 250 15 300 30 375 35 500 50 650 45 750 60 850	psid	Ranges ≤ 10 psi are calibrated over the range of -FS to +FS pressure Ranges > 10 psi and < 100 psi are calibrated over the range of -12 psi to +FS pressure ranges □ 100 psi are unidirectional only
Number of Measurement Inputs	16		
Pneumatic Fittings	0.063 bulged tubulations or SAE 5/16-24 o-ring boss (if front access specified)		Variety of compression adapters fittings available. See page 6 for standard fittings
Media	Dry, non-corrosive gas		non-corrosive gas
Proof Pressure ¹	3.0X 2.0X 1.5X	FS min	Range < 15 psi Range 15-100 psi Range > 100 psi
Burst Pressure	5.0X 3.0X 2.0X	FS min	Range < 15 psi Range 15-100 psi Range > 100 psi
Max Line Pressure ²	100 600	psi	Range ≤ 5 psi Range > 5 psi
Manifold Control Pressure	100 125	psi	min max
Purge Pressure ³	> max input pressure 850	psi	min max

RACKMOUNT INTELLIGENT PRESSURE SCANNER 9916

NETSCANNER 9916

STATIC PERFORMANCE

PARAMETER	9916	UNITS	COMMENTS
Measurement resolution	±0.003	% FS	
Static Accuracy ⁴ After Rezero	±0.05 ±0.15	% FS	Range > 2.5 psi Range ≤ 2.5 psi
Total Thermal Error ⁶	±0.001 ±0.0015	% FS/°C % FS/°C	Range > 2.5 psi Range ≤ 2.5 psi
Line Pressure Effect	±0.0003 ±0.0008 ±0.001	% FS/psi % FS/psi % FS/psi	Range ≥ 100 psi Range > 5 psi to < 100 psi Range ≤ 5 psi
Measurement Rate	100	ch/sec	Engineering Units

COMMUNICATION

PARAMETER	9916	UNITS	COMMENTS
Ethernet	10/100 Base T	Auto negotiating half/full duplex	Ethernet
Protocol	TCP and UDP	Static or dynamic IP assignment	Protocol
Time Protocol	PTPv2 (IEEE 1588- 2008) or NTP	External master clock or server required	Time Protocol

THEORY OF OPERATION

The Model 9916 Rackmount Intelligent Pressure Scanner combines the integral pressure transducers with a miniature data acquisition system to provide a multichannel pressure scanner. The integration of the microprocessor with the pressure transducers provides several benefits in addition to the self-contained nature of the Intelligent Pressure Scanner. This pre-engineered approach to pressure acquisition offers higher system accuracy, unlike individual pressure transducers where stated accuracy is met only if the many user-considerations are addressed, especially with respect to temperature effects and zero drift. The 9916 outputs pressure data in engineering units, digitally compensated for zero, span, nonlinearity and temperature effects. The integral pneumatic manifold permits on-line rezero and even span calibration capability under microprocessor control.

RACKMOUNT INTELLIGENT PRESSURE SCANNER 9916

NETSCANNER 9916

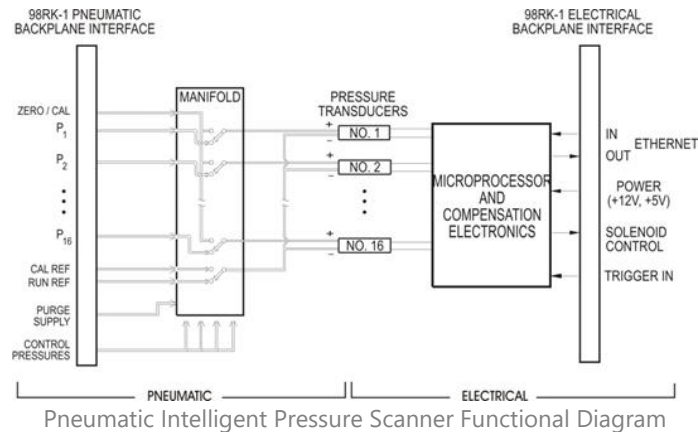

DIGITAL SENSOR TEMPERATURE COMPENSATION

Silicon piezoresistive pressure sensors are low cost, miniature pressure sensing elements suited for packaging individually for each pressure port. However, like most sensors, they are affected by temperature. Since these effects are repeatable, sensor calibration over temperature and pressure can be used to characterize and correct these errors.

Each silicon pressure sensor is packaged along with a nonvolatile memory device (EEPROM) and temperature sensor in its own miniature field-replaceable housing. The transducers are factory-calibrated over the specified pressure and temperature spans. The resultant calibration data, along with the pressure range and serial number of the sensor, are stored in the integral EEPROM. The microprocessor utilizes this information to compensate transducer outputs for offset, sensitivity, nonlinearity, and thermal effects before transferring pressure data to the host computer. Should a transducer be replaced, the microprocessor will recognize the new transducer upon power up and extract the calibration information from the EEPROM.

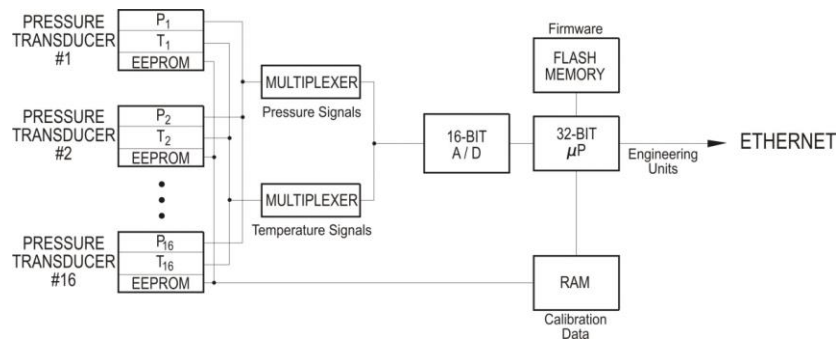

Digital Sensor Temperature Compensation Functional Diagram

INTERNAL CLOCKS AND TIME KEEPING

The 9916 contains an internal real time clock (RTC) for keeping system date and time. This clock is factory initialized to UTC-0 time. The 9916 also has the ability to continually synchronize its internal RTC to either an NTP server or IEEE 1588-2008 Precision Time Protocol (PTPv2) grandmaster clock if they are present and accessible on the 9916's network. As part of the 9916 data stream configuration, data samples may optionally include an absolute time stamp indicating when the data sample was acquired. It is also possible to configure 9916 data streams to start autonomously at a set absolute time. This is useful for initiating data streaming synchronously through a large 9916 configuration without the use of the hardware trigger signal.

PNEUMATIC DESIGN

The Model 9916 Rackmount Intelligent Pressure Scanner incorporate a unique manifold enabling on-line pneumatic rezero and span calibrations to maximize transducer accuracy. The manifold can be specified with either a common pressure reference or an individual pressure reference (true differential) per channel. Both configurations feature built-in purge and leak check capability of the pneumatic input lines as standard. The manifold utilizes a proprietary O-ring seal providing years of leak free operation. If required, O-rings can be replaced in the field using common tools.

Figures 1-4 illustrate the pneumatic function of the manifold for a single channel. Figures 1-3 depict the three manifold positions (RUN, CAL and PURGE). Figure 4 illustrates the LEAK CHARGE position for charging the input lines to execute a leak check.

To initiate these operations, the user simply issues the appropriate command via the host computer. Operating under control of the onboard microprocessor, integral solenoids are energized to apply control pressure to two of four pistons within the manifold. One piston forces the manifold longitudinally into the CAL position; another returns it to the RUN position. The remaining two pistons force the manifold laterally into either the PURGE or the LEAK CHARGE positions. Pressure of 100-125 psig must be present at the Control Pressure Supply Input port on the rear of the 98RK-1 rack when the command is issued.

Rezero or span calibration functions place the manifold in the CAL position. Once there, data is acquired to update zero and/or span terms and the manifold is then returned to the RUN position. Span calibrations require the appropriate full-scale pressure to be present at the respective calibration input ports on the rear of the rack.

The purge function requires pressure in excess of the highest anticipated input pressure to be present at the Purge Input port on the rear of the rack. Issuing the Purge command places the manifold into the PURGE position allowing purge pressure to exit the scanner through the input lines. Purging can require 1-3 scfm of flow depending on applied purge pressure.

NOTE: On-line rezero or purge is not required to operate the scanner but provides maximum accuracy.

The LEAK CHARGE function requires the desired test pressure to be applied to the appropriate calibration port on the rear of the rack and the input lines to be dead-ended at their source. Issuing the LEAK CHARGE command forces the manifold into the LEAK CHARGE position to charge the input lines using pressure from the respective calibration ports. Once charged, the manifold is commanded to the RUN position where periodic reading from the transducers can be obtained to analyze pressure decay in each input line.

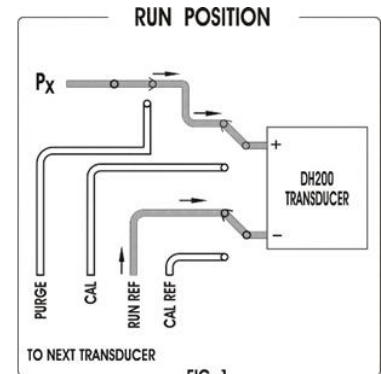

FIG. 1

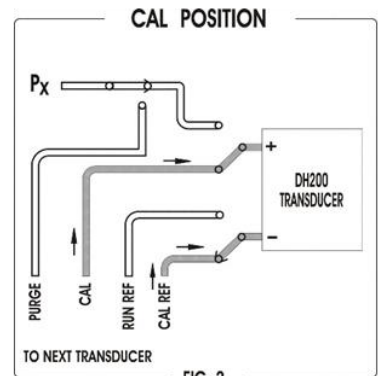

FIG. 2

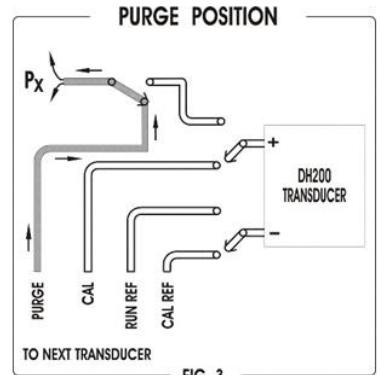

FIG. 3

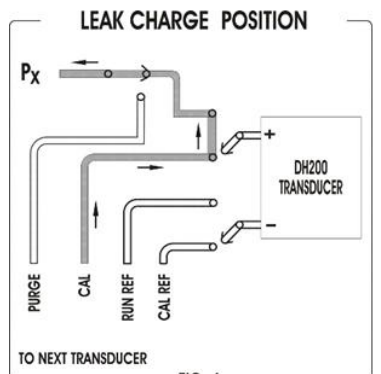

FIG. 4

RACKMOUNT INTELLIGENT PRESSURE SCANNER 9916

NETSCANNER 9916

ORDERING INFORMATION

PN: 9916-AABBCC0000 **9916 Rackmount Intelligent Pressure Scanner**
AA=Pressure Range

01, ±10" WC	08, -12 to 30 psid	24, -12 to 50 psid	34, 0 - 75 psid
02, ±20" WC	09, -12 to 45 psid	25, 0 - 650 psid	39, 0 - 850 psid
03, ±1 psid	10, 0 -100 psid	26, 0 - 200 psid	99, Multirange
04, ±2.5 psid	11, 0 - 250 psid	27, -12 to 35 psid	
05, ±5 psid	12, 0 - 500 psid	30, 0 - 150 psid	
06, ±10 psid	20, 0 - 300 psid	31, 0 - 375 psid	
07, -12 to 15 psid	23, 0 - 125 psid	32, 0 - 750 psid	

BB = Pneumatic Connection

- 01, 0.063", Front Access QDC
- 02, 0.063", Rear Access QDC
(BB = 01)
- 03, 1/8" Compression Fitting, Front Access
- 05, 4mm Compression Fitting, Front Access

CC = Manifold Options

- 06, Common Differential
- 07, True Differential, Front Access QDC only
- 08, Common Differential, Dual Reference

GLOBAL

1000 Lucas Way
Hampton, VA 23666 USA
Tel +1 800 522 6752
customercare.hmpt@te.com

TE.com/sensorsolutions

Measurement Specialties, Inc., a TE Connectivity company.

NetScanner, TE Connectivity, TE connectivity (logo) and EVERY CONNECTION COUNTS are trademarks. All other logos, products and/or company names referred to herein might be trademarks of their respective owners.

The information given herein, including drawings, illustrations and schematics which are intended for illustration purposes only, is believed to be reliable. However, TE Connectivity makes no warranties as to its accuracy or completeness and disclaims any liability in connection with its use. TE Connectivity's obligations shall only be as set forth in TE Connectivity's Standard Terms and Conditions of Sale for this product and in no case will TE Connectivity be liable for any incidental, indirect or consequential damages arising out of the sale, resale, use or misuse of the product. Users of TE Connectivity products should make their own evaluation to determine the suitability of each such product for the specific application.

© 2019 TE Connectivity Ltd. family of companies All Rights Reserved.