

HIGH VOLTAGE CONTACTORS ECP 600B SERIES

UP TO 800AMP

INTRODUCTION

TE Connectivity (TE)'s ECP600B series high-voltage DC contractor is designed for control in high voltage environments like battery energy storage system, solar inverters, and EV charging applications. It can be used in 1500VDC voltage systems, and the enhanced insulation distance can fully meet the requirement of UL60947-4-1 & IEC60947-4-1 standards. The contacts provided in this series, allows bi-directional load and hermetically sealed with ceramic sealing technology, makes it safe and reliable.

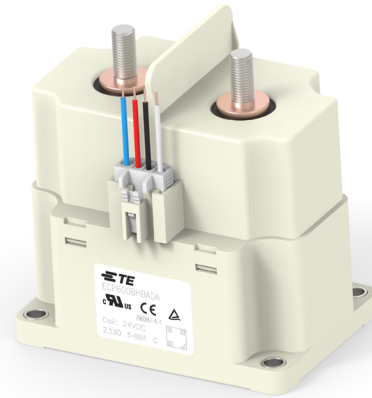

FEATURES

- Hermetically sealed with ceramic technology
- Continuous current carrying capacity of 800A
- Max. breaking capacity up to 1500VDC at 1000A
- Allows bi-directional load
- Dual coil design withholding 5.0W of power
- Equipped with auxiliary contact
- Compatibility with DC-1 utilization category in IEC60947-4-1

APPLICATION

ECP600B contactors can be used for multiple applications including some of the below highlighted

- Battery energy storage systems
- Photovoltaic inverters
- Power conversion system
- Megawatt EV DC charger

APPROVALS

UL, TUV, CE



Note: Technical data of approved types on request

ECP600B SERIES

HIGH VOLTAGE CONTACTORS

MAIN CONTACT DATA

Contact current	800A
Max. switching voltage	1500VDC
Max. Breaking Capacity	1500VDC, 1000A, 1 cycle 1500VDC, 800A, 3 cycles 1000VDC, 2000A, 1 cycle
Contact arrangement	1 Form X (SPST-NO-DM)
Initial contact resistance	≤ 0.4mOhm (600A, after 1 minute)
Operate time max. (at 23°C)	50ms
Release time, max. (at 23°C)	30ms
Mechanical Life	200,000 cycles

COIL VERSIONS, DC COIL

Coil Code	Nominal Voltage	Operate Voltage	Release Voltage	Maximum Operate Voltage	Coil Power
A	12VDC	≤ 9VDC	≥ 1.2VDC	16VDC	Start: 50W Hold: 5W
B	24VDC	≤ 18VDC	≥ 2.4VDC	32VDC	Start: 50W Hold: 5W

All figures are given for coil without pre-energization, at ambient temperature +23°C, and the coil will be automatically switched to 5W hold status after about 200ms energization with coil power 50W.

CONTACT RATINGS

Load	Cycles
100A, 1500VDC, make/break, resistive	6,000
250A, 1500VDC, make/break, resistive	1,100
600A, 1000VDC, break only, resistive	100
600A, 1500VDC, break only, resistive	20

NOTE:

- Only typical rating listed, please refer to make/break curves in next page for more details at different current and voltage.

INSULATION DATA

Dielectric Withstand Voltage (leakage current <1mA)	
Between open main contacts	4,000 V _{rms}
Between main contact and coil	4,000 V _{rms}
Between main contacts and aux contacts	4,000 V _{rms}
Between open aux contacts	750 V _{rms}
Initial Insulation Resistance @ 1000VDC	
Between insulated elements	> 1x10 ⁹ Ω

CE DECLARATION (IEC60947-4-1)

Rated Operational Current	Rated Operational Voltage	Utilization Category	Switching Cycles
60A	1500VDC	DC-1	6,050

OTHER DATA

Material compliance	EU RoHS/ELV, China RoHS, REACH, Halogen content refer to the Product Compliance Support Center at www.te.com/customer-support/rohssupportcenter
Ambient Temperature	-40°C to 85°C
Vibration Resistance (functional)	Sine, 10-2000Hz, 5G
Shock Resistance (functional)	11ms 1/2 Sine, Peak 20G
Terminal Type	Screw for contact, wire for coil
Weight	~1350g
Packaging/unit	box/9 pcs.

AUXILIARY CONTACT DATA

Contact Form	1 Form A (SPST-NO)
Contact Current, Max.	2A, 24VDC
Contact Current, Min.	10mA, 24VDC

CURRENT CARRY CAPABILITY CURVE

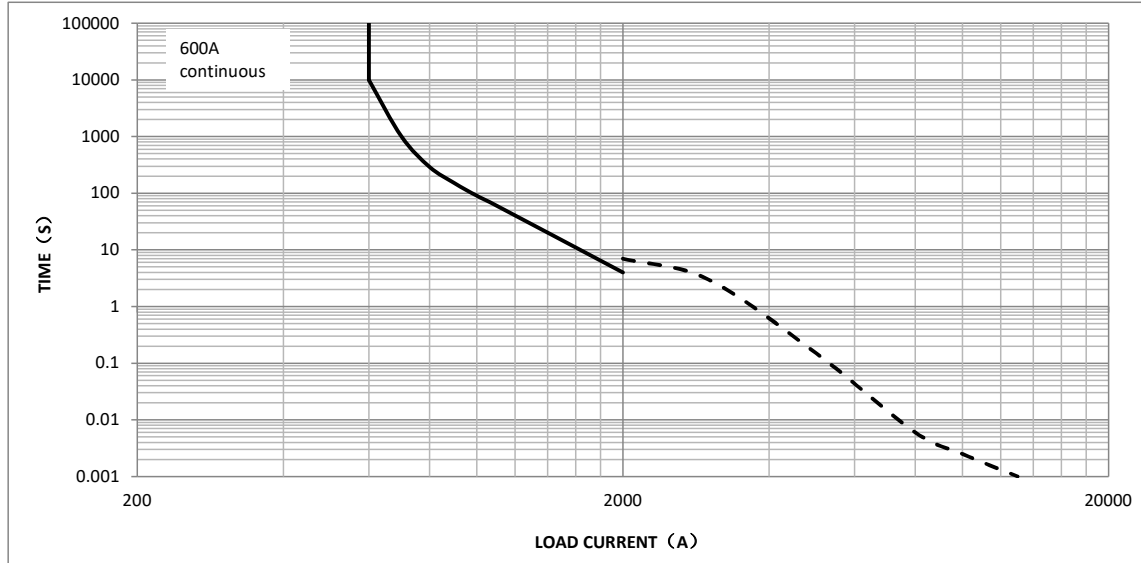

NOTE

1. ——— Overload current carry endurance. The data is measured at the environment temperature 85°C with cross section area of wire 370mm² min.
2. - - - Short circuit current endurance. The data is measured at the environment temperature 23°C with cross section area of wire 370mm² min. >2000A short circuit current, the judgement criteria of the above reference data is no burning or explosion.
3. For 800A current application, recommend >480mm² conductor size and please users select the appropriate connection conductor cross section or active cooling to control the temperature. Keep main contact terminals 130°C max for long-term continuous carry, 170°C max for two hours.

ESTIMATED MAKE & BREAK POWER SWITCHING RATINGS

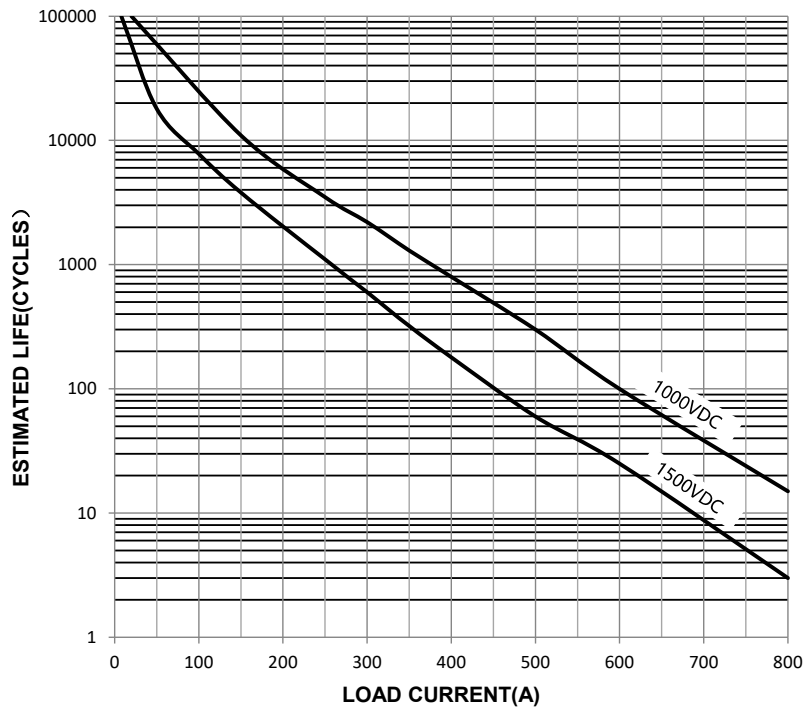

Notes:

1. The curve was created based on extrapolated data with few typical points, users are recommended to confirm performance in actual application.
2. The typical data were estimated with resistive load at room temperature.
3. At 1000VDC, less than 350A were estimated under make and break, 1s on/9s off; over 350A were estimated under break only, 1s on/60s off.
4. At 1500VDC, less than 200A were estimated under make and break, 1s on/9s off; over 200A were estimated under break only, 1s on/60s off; over 600A were estimated under break only, 0.05s on / 300s off.

ECP600B SERIES

HIGH VOLTAGE CONTACTORS

DIMENSIONS (Unit: mm)

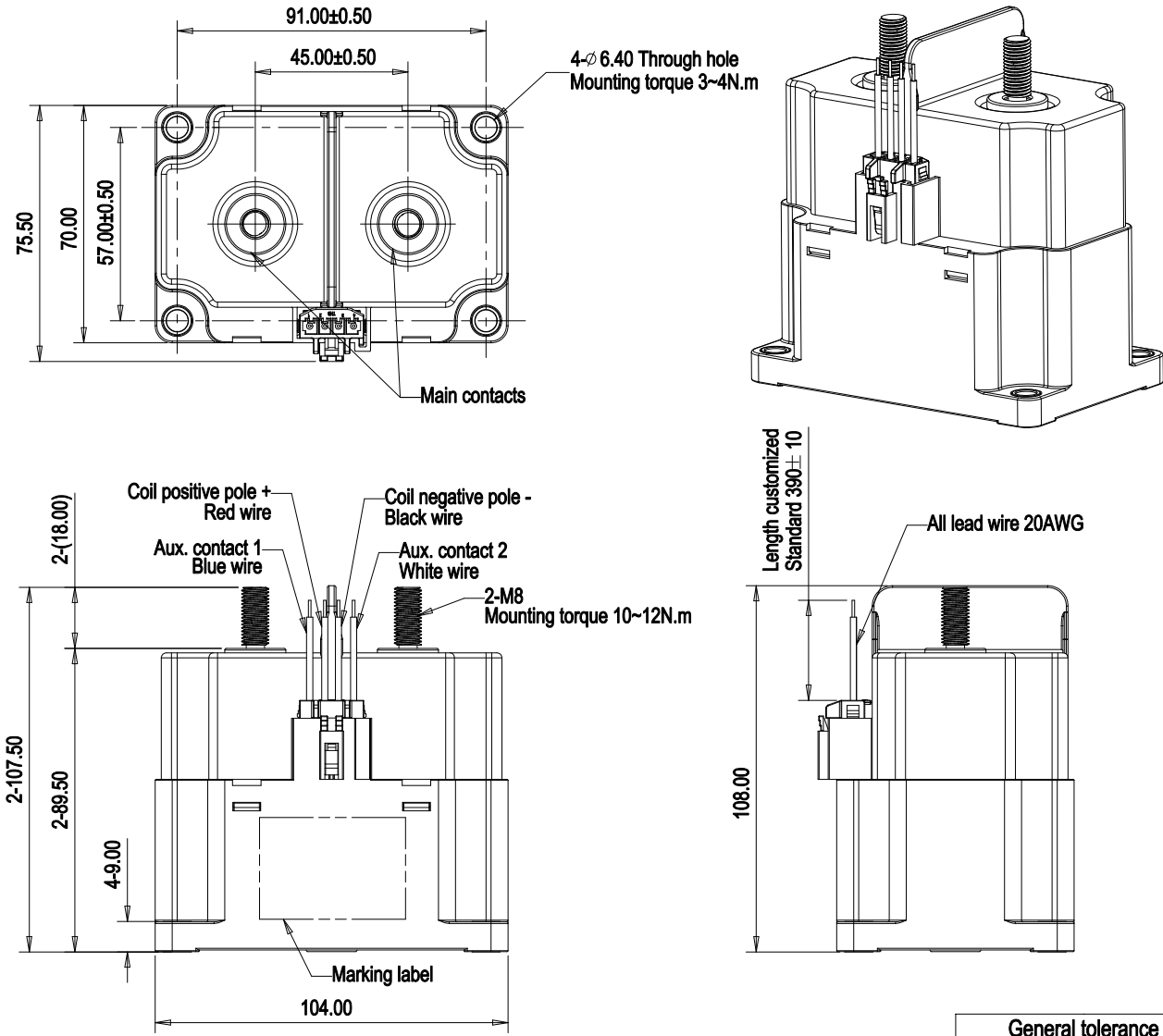

General tolerance	
Dimension	Tolerance
<10	±0.4
10~50	±0.8
>50	±1.2

CIRCUIT DIAGRAM

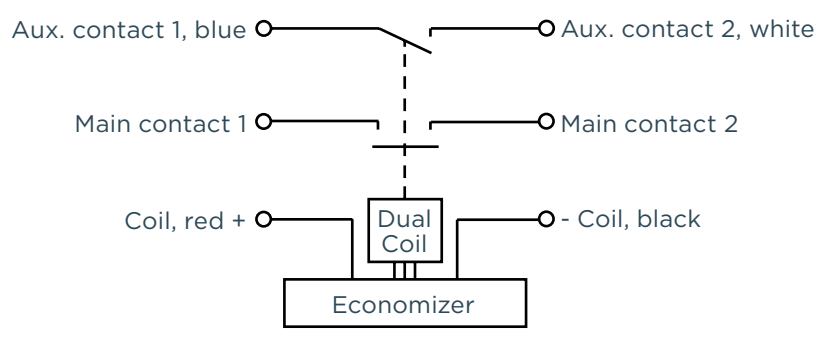

ECP600B SERIES

HIGH VOLTAGE CONTACTORS

PRODUCT INFORMATION

Product code	Contact Form	Mounting Position	Coil	Coil Control Mode	Part Number
ECP600BHAADA	Normally open, with auxiliary contacts (N.O.)	Bottom	12VDC	Dual coil	1-2071582-1
ECP600BHBADA			24VDC		1-2071582-2

PRODUCT CODE STRUCTURE

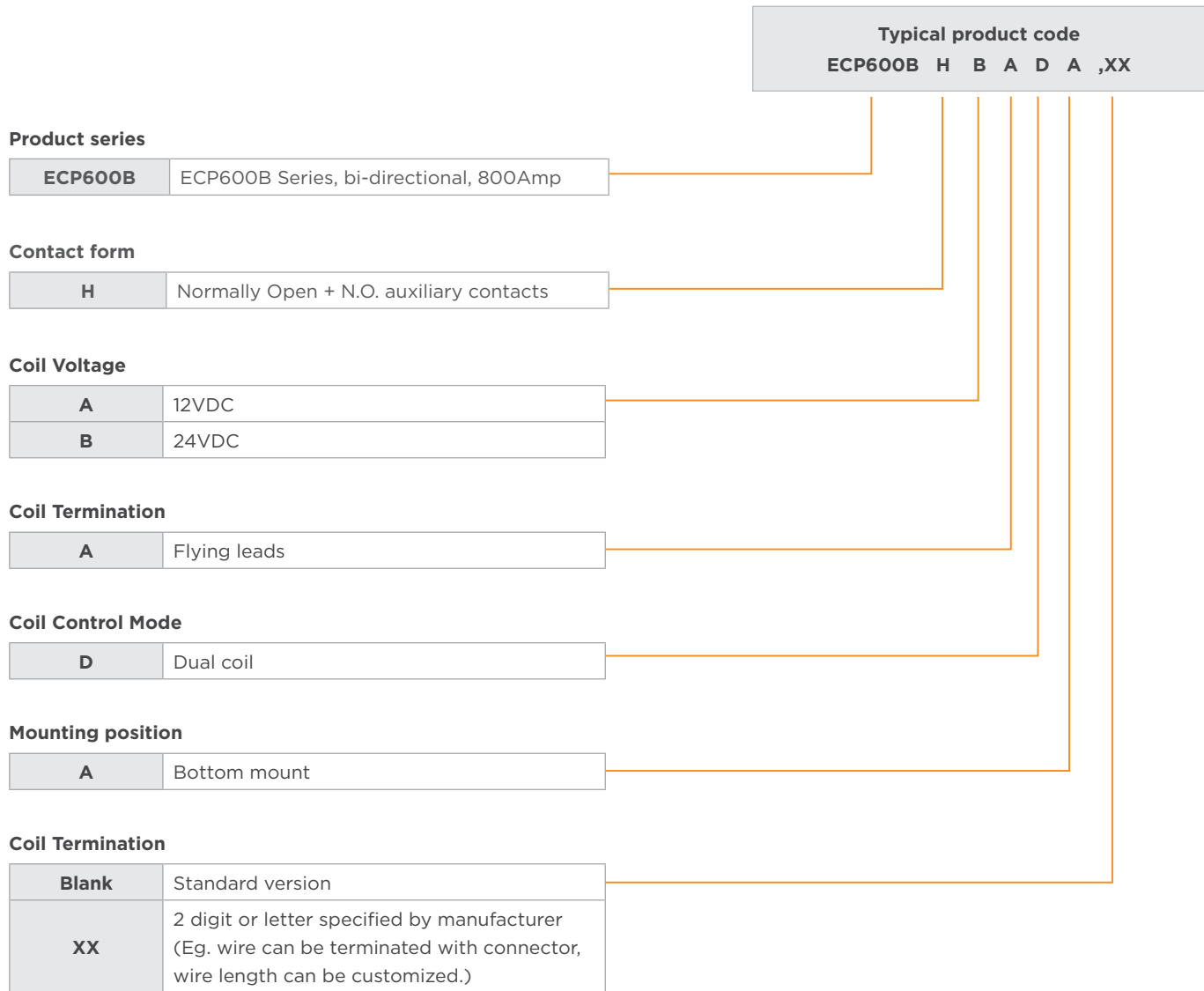

CAUTIONS

1. Do not use the product when product is dropped or broken.
2. Avoid mounting the contactor main contact terminals in downward direction, otherwise the contactor performance will not be guaranteed.
3. There is no polarity difference at the load connection end of this contactor, and no polarity difference at the auxiliary contact connection end. There is a polarity difference at the coil connection end: the red wire is connected to the positive pole of the control power supply, and the black wire is connected to the negative terminal of the control power supply. Please pay attention to the correct installation and use.
4. The nominal value of the contact is the value when the resistive load is applied. In the case of an inductive load (L-load) of $L/R \geq 1\text{ms}$, take surge absorption measures in parallel with the inductive load. Otherwise the electrical performance cannot be guaranteed.
5. This product has built-in coil suppression reverse electromotive force circuit, so it does not require surge suppression device. When performing this action voltage test, the voltage cannot rise slowly, Please drive the product coil through the fast rising (step type power supply mode), otherwise the contactors will not operate.
6. The coil type of this product is dual coil, and the coil will be automatically switched to "hold" status after about 0.2 seconds of energization, and the contactor may not operate if energization is less than 0.2s.
7. It is strictly forbidden to place the contactor in an environment that exceeds the temperature range of the product (-40°C - $+85^{\circ}\text{C}$) for a long time.
8. Please avoid installing near strong magnetic boundaries (around transformers and magnets) and heating objects.
9. In order to prevent loosening, please use the gasket correctly when installing the contactor. Screw locking torque of main contact terminals should be 10-12 N·m for M8 screw. Screw locking torque of product bottom mounting should be 3-4 N·m for M5 screw.
10. Please avoid adhering to foreign matter such as grease on the lead end, To maintain the maximum long-term performance, user should select the appropriate connection cable cross section or active cooling to control the temperature.

Notes:

1. Datasheets and product specification according to IEC 61810-1, EN/IEC60947-4-1, UL60947-4-1 and to be used only together with the 'Definitions' section.
2. Datasheets and product data is subject to the terms of the disclaimer and all chapters of the 'Definitions' section, available at <http://relays.te.com/definitions>.
3. Datasheets, product data, 'Definitions' section, application notes and all specifications are subject to change.

te.com

©2023 TE Connectivity. All Rights Reserved.

TE Connectivity, TE connectivity (logo) and Every Connection Counts are trademarks. All other logos, products and/or company names referred to herein might be trademarks of their respective owners.

The information given herein, including drawings, illustrations and schematics which are intended for illustration purposes only, is believed to be reliable. However, TE Connectivity makes no warranties as to its accuracy or completeness and disclaims any liability in connection with its use. TE Connectivity's obligations shall only be as set forth in TE Connectivity's Standard Terms and Conditions of Sale for this product and in no case will TE Connectivity be liable for any incidental, indirect or consequential damages arising out of the sale, resale, use or misuse of the product. Users of TE Connectivity products should make their own evaluation to determine the suitability of each such product for the specific application.

10/23 ED