

## GOLD CHIP THERMISTOR GA10K3CG582

### Description

TE Connectivity offers a comprehensive range of Gold terminated leadless NTC chip thermistors for today's hybrid microelectronics needs. With metallization on top and bottom surfaces, attachment to hybrid, IC or PC circuits is accomplished using industry standard die attach and wire bonding techniques. Chips may be soldered or bonded with conductive epoxy to board termination points where space is at a premium. Typical square-chip sizes range from 0.35 mm to 1.2 mm depending on the preferred ceramic system and nominal ohmic resistance. MTTF reliability information is provided for the complete range of gold chip products for customer selection and design-in. Gold terminated NTC thermistors are supplied in "waffle" packs for protection and ease of customer handling.

### Features

- Gold electrodes suitable for wire bonding
- Mount directly to substrate for fast time-response
- Temperature range -40°C to +125°C
- High stability performance with additional aging steps
- Delivers advanced electro-ceramic materials with fine grained microstructure
- Packed in waffle trays

### Applications

- WDM (Wavelength Division Multiplexing) for advanced frequency control in communications systems and wireless applications
- Thermopile sensors for thermal radiation recognition and infrared sensing
- Thermal protection of sensitive circuits
- Hybrid circuit temperature compensation
- Localized temperature sensing
- Laser diode modules

### Specifications

- 10K Ohms Resistance @ +25°C
- $\pm 2\%$  Resistance Tolerance @ +25°C
- Rapid Time Response
- $\text{Beta}_{25/85} = 3976 \pm 1.0 \%$

[CLICK HERE >](#)  
**CONNECT WITH A SPECIALIST**

## GOLD CHIP THERMISTOR GA10K3CG582

### Performance specifications

| Parameters                     | Units   | Value         |
|--------------------------------|---------|---------------|
| Resistance @ +25°C             | Ohms    | 10,000        |
| Resistance Tolerance @ +25°C   | %       | ±2            |
| Beta Value 25/85               | K       | 3976          |
| Tolerance on Beta Value 25/85  | %       | ±1            |
| Operating Temperature          | °C      | -40 to +125°C |
| Thermal Time Constant in Air * | Seconds | < 2           |
| Dissipation Constant *         | mW/°C   | ≥ 0.25        |
| Maximum Power Dissipation *    | mW      | 25            |

**Note:** Time Response and DC measurements performed with Alloy 180 Lead wires Ø 0.2mm (0.008”) soldered to chip

### Mechanical details

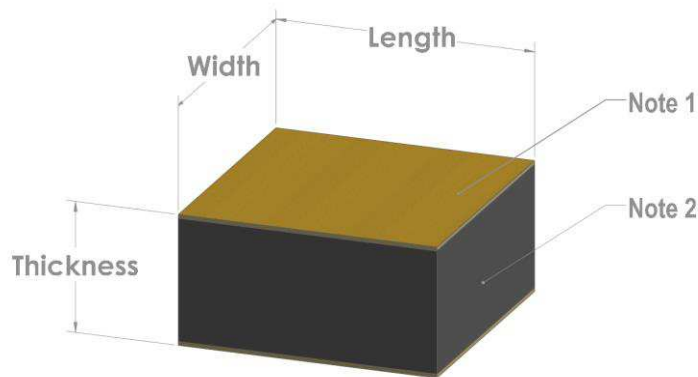

#### Dimensions

| Thickness               | Width                   | Length                  |
|-------------------------|-------------------------|-------------------------|
| 0.20mm Min - 0.30mm Max | 0.38mm Min - 0.48mm Max | 0.38mm Min - 0.48mm Max |

#### Notes

|   |  |
|---|--|
| 1 | Gold Metallization - Top and Bottom electrodes |
| 2 | TE Electro Ceramic Material: BT3Lo-D           |

Reliability performance

**Environmental Testing Data, TE Material BT3Lo-D Gold Chip NTC**

| Test   | Test Conditions and Duration  | Performance   |
|--|---|---|
| <p><b>High Temperature Exposure (T1)</b></p> | <p><b>Exposure Temperature = +50°C</b><br/>                     Duration = 2,000 Hours<br/>                     Test specimens mounted on CerDIP package and placed in a hotbox oven.</p>   | <p>Delta Resistance (%ΔR) @ +25°C after 2,000 hours exposure to Test Condition T1.<br/>                     Delta Resistance (%ΔR) calculated against 0-hour readings.<br/>                     Max allowable Delta = +/- 1%<br/>                     Result = Pass</p> |
| <p><b>High Temperature Exposure (T2)</b></p> | <p><b>Exposure Temperature = +75°C</b><br/>                     Duration = 2,000 Hours<br/>                     Test specimens mounted on CerDIP package and placed in a hotbox oven.</p>   | <p>Delta Resistance (%ΔR) @ +25°C after 2,000 hours exposure to Test Condition T2.<br/>                     Delta Resistance (%ΔR) calculated against 0-hour readings.<br/>                     Max allowable Delta = +/- 1%<br/>                     Result = Pass</p> |
| <p><b>High Temperature Exposure (T3)</b></p> | <p><b>Exposure Temperature = +100°C</b><br/>                     Duration = 2,000 Hours<br/>                     Test specimens mounted on CerDIP package and placed in a hotbox oven.</p>  | <p>Delta Resistance (%ΔR) @ +25°C after 2,000 hours exposure to Test Condition T3.<br/>                     Delta Resistance (%ΔR) calculated against 0-hour readings.<br/>                     Max allowable Delta = +/- 1%<br/>                     Result = Pass</p> |
| <p><b>High Temperature Exposure (T4)</b></p> | <p><b>Exposure Temperature = +125°C</b><br/>                     Duration = 2,000 Hours<br/>                     Test specimens mounted on CerDIP package and placed in a hotbox oven.</p>  | <p>Delta Resistance (%ΔR) @ +25°C after 2,000 hours exposure to Test Condition T4.<br/>                     Delta Resistance (%ΔR) calculated against 0-hour readings.<br/>                     Max allowable Delta = +/- 1%<br/>                     Result = Pass</p> |
| <p><b>Low Temperature Exposure</b></p>       | <p><b>Exposure Temperature = -40°C</b><br/>                     Duration = 1,000 Hours<br/>                     Test specimens mounted on CerDIP package and placed in a low temperature chamber. Test specimens allowed to stand under ambient conditions for 2 hours +/- 1 hour prior to zero-power resistance check.</p> | <p>Delta Resistance (%ΔR) @ +25°C after 1,000 hours exposure to test condition.<br/>                     Delta Resistance (%ΔR) calculated against 0-hour readings.<br/>                     Max allowable Delta = +/- 1%<br/>                     Result = Pass</p>    |

**Environmental Testing Data, TE Material BT3Lo-D Gold Chip NTC**

| Test   | Test Conditions and Duration  | Performance   |
|--|---|---|
| <p><b>Humidity Storage Test</b></p>          | <p><b>Exposure Condition = +85°C at 85% Relative Humidity</b><br/>                     Duration = 1,000 Hours<br/>                     Test specimens mounted on CerDIP package and placed in a humidity chamber. Test specimens allowed to stand under ambient conditions for 2 hours +/- 1 hour prior to zero-power resistance check.</p>   | <p>Delta Resistance (%ΔR) @ +25°C after 1,000 hours exposure to test condition.<br/>                     Delta Resistance (%ΔR) calculated against 0-hour readings.<br/>                     Max allowable Delta = +/- 1%<br/>                     Result = Pass</p>    |
| <p><b>Thermal Shock Test</b></p>             | <p><b>Thermal Shock = -40°C to +85°C</b><br/> <b>30 mins @ -40°C ---&gt; 5 sec transfer ---&gt; +85°C</b><br/> <b>Total Cycle Time = 1 hour</b><br/>                     Number of Thermal Shock Cycles = 1,000<br/>                     Test specimens mounted on CerDIP package and placed in a Thermal Shock Chamber.</p>  | <p>Delta Resistance (%ΔR) @ +25°C after 1,000 Thermal Shock Cycles.<br/>                     Delta Resistance (%ΔR) calculated against 0-Cycle Thermal Shock readings.<br/>                     Max allowable Delta = +/- 1%<br/>                     Result = Pass</p> |
| <p><b>High Temperature Power Loading</b></p> | <p><b>Exposure Condition = +100°C</b><br/> <b>Supply Voltage +0.11VDC</b><br/>                     Duration = 1,000 Hours<br/>                     Test specimens mounted on CerDIP package and placed in a high temperature chamber with DC voltage applied.</p>   | <p>Delta Resistance (%ΔR) @ +25°C after 1,000 hours exposure to test condition.<br/>                     Delta Resistance (%ΔR) calculated against 0-hour readings.<br/>                     Max allowable Delta = +/- 1%<br/>                     Result = Pass</p>    |
| <p><b>Wire Bond Strength</b></p>             | <p>Wire Bond Strength testing conducted as per <b>MIL-STD-883, Test Method 2011, Section 3.1.3, Test Condition D - Wire pull (double bond)</b>.<br/>                     25μm Au wire bonded to top electrode of NTC Gold Chip using ball bonding process. Wire Bond Strength testing performed using a Dage Series 4000 Bond tester.</p>   | <p>Test specimens exceeded the MIL-STD-883, Method 2011, minimum strength of <b>3.00g</b>.<br/>                     Result = Pass</p>   |
| <p><b>Die Shear Strength</b></p>             | <p>Die Shear Strength testing conducted to assess the integrity of the die-to-bonding pad interface as per <b>MIL-STD-883, Test Method 2019, Section 3.2.1 Epoxy Attach &amp; Figure 2019-4 (Die Shear Strength Criteria)</b>.<br/>                     Die attach material is silver loaded epoxy (Epo-Tek H35-175MPLV). Die Shear testing performed using a Dage Series 4000 Bond tester.</p> | <p>Test specimens exceeded the MIL-STD-883, Method 2019, minimum strength of <b>229.28g</b>.<br/>                     Result = Pass</p>   |

**Reliability and Lifetime:**

The Gold Chip Thermistor operating lifetime has been calculated using accelerated life test principles. For the tests, the specimens were mounted in CerDIP packages using a silver filled epoxy to form the mechanical, thermal and electrical bond to the substrate. A gold wire bond was used to connect to the top electrode. The thermistors were subjected to unpowered storage at select temperatures between +50°C and +125°C. Periodic calibrations were taken to understand drift in resistance over time. Based on this data, a lifetime prediction model was applied to estimate Mean Time To Failure (MTTF) for operation at typical application temperatures. The criteria for failure was drift in resistance values at a reference temperature of +25°C with the model being applied for different allowable percentage drift values, as indicated below:

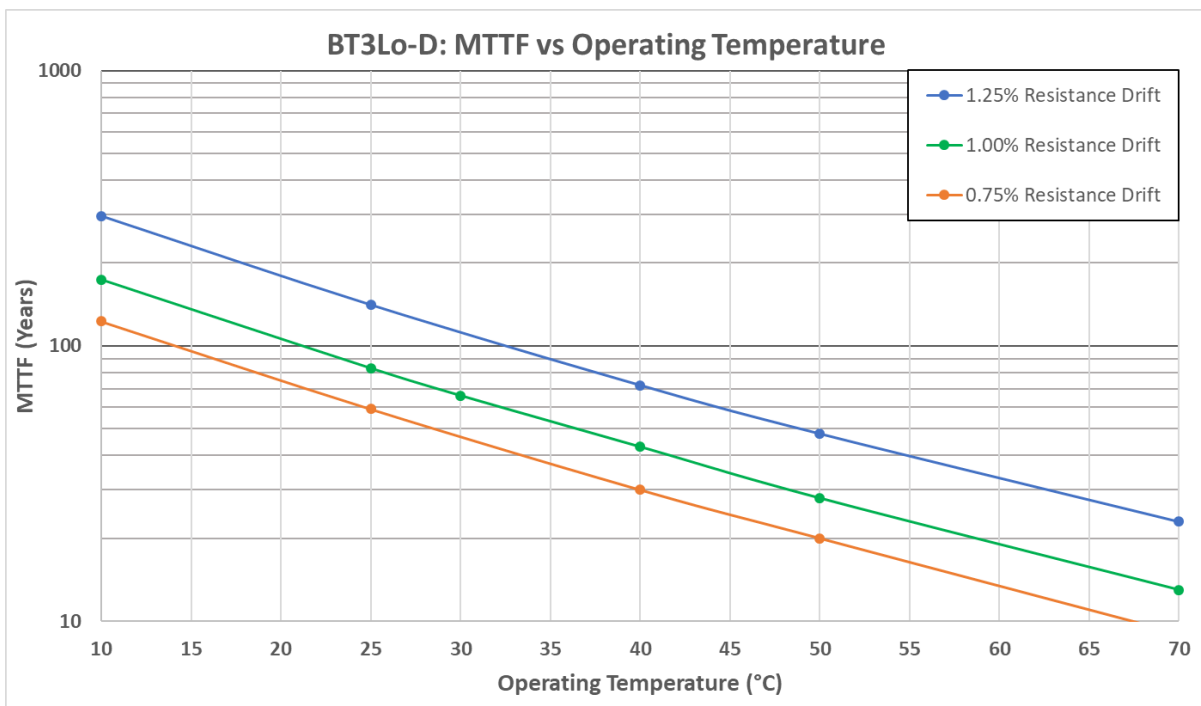

Product packaging – waffle tray H20-021-12 -62C02

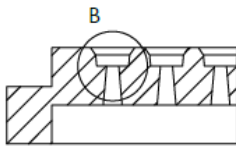
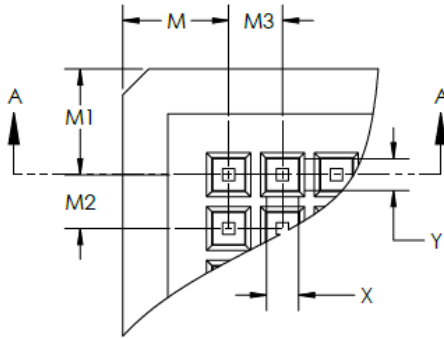

SECTION A-A

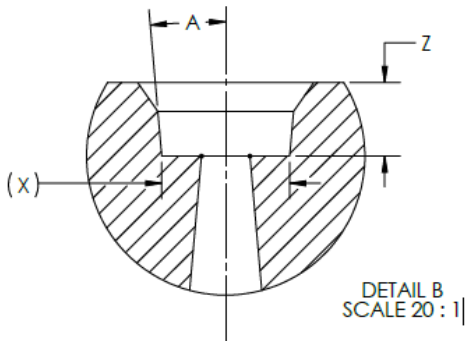

**Pocket Locations**

- M =  $8.00 \pm 0.13\text{mm}$
- M1 =  $8.00 \pm 0.13\text{mm}$
- M2 =  $1.83 \pm 0.13\text{mm}$
- M3 =  $1.83 \pm 0.13\text{mm}$
- Array = 20x20 (400)

**Pocket Details**

- X = 0.56mm pocket size
- Y = 0.56mm pocket size
- Z = 0.31mm pocket depth
- A =  $14^\circ \pm 1/2^\circ$  pocket draft angle

**No cross slots**

**Overall Tray Size**

- Size =  $50.67 \pm 0.25\text{mm}$
- Height =  $3.94 + 0.08\text{mm} - 0.13\text{mm}$
- Flatness = 0.30mm

## GOLD CHIP THERMISTOR GA10K3CG582

### Resistance v temperature table

| Temp °C | Ohms     |
|---------|----------|
| -40     | 336097.6 |
| -39     | 314552.9 |
| -38     | 294524.4 |
| -37     | 275896.6 |
| -36     | 258563.2 |
| -35     | 242426.8 |
| -34     | 227397.8 |
| -33     | 213393.7 |
| -32     | 200338.8 |
| -31     | 188163.2 |
| -30     | 176802.7 |
| -29     | 166197.9 |
| -28     | 156294.4 |
| -27     | 147041.6 |
| -26     | 138393.2 |
| -25     | 130306.3 |
| -24     | 122741.1 |
| -23     | 115661.1 |
| -22     | 109032.4 |
| -21     | 102823.7 |
| -20     | 97006.1  |
| -19     | 91552.6  |
| -18     | 86438.5  |
| -17     | 81640.8  |
| -16     | 77138.1  |
| -15     | 72910.6  |
| -14     | 68940.0  |
| -13     | 65209.3  |
| -12     | 61702.6  |
| -11     | 58405.2  |
| -10     | 55303.6  |
| -9      | 52384.9  |
| -8      | 49637.5  |
| -7      | 47050.3  |
| -6      | 44613.2  |
| -5      | 42316.5  |
| -4      | 40151.5  |
| -3      | 38109.8  |
| -2      | 36183.9  |
| -1      | 34366.4  |
| 0       | 32650.8  |
| 1       | 31030.7  |

| Temp °C   | Ohms           |
|-----------|----------------|
| 2         | 29500.4        |
| 3         | 28054.3        |
| 4         | 26687.4        |
| 5         | 25395.0        |
| 6         | 24172.5        |
| 7         | 23015.8        |
| 8         | 21921.1        |
| 9         | 20884.7        |
| 10        | 19903.2        |
| 11        | 18973.3        |
| 12        | 18092.1        |
| 13        | 17256.9        |
| 14        | 16464.9        |
| 15        | 15713.6        |
| 16        | 15000.9        |
| 17        | 14324.5        |
| 18        | 13682.3        |
| 19        | 13072.6        |
| 20        | 12493.3        |
| 21        | 11943.0        |
| 22        | 11419.9        |
| 23        | 10922.7        |
| 24        | 10449.8        |
| <b>25</b> | <b>10000.0</b> |
| 26        | 9572.0         |
| 27        | 9164.7         |
| 28        | 8777.0         |
| 29        | 8407.7         |
| 30        | 8056.1         |
| 31        | 7721.0         |
| 32        | 7401.7         |
| 33        | 7097.3         |
| 34        | 6807.1         |
| 35        | 6530.3         |
| 36        | 6266.2         |
| 37        | 6014.3         |
| 38        | 5773.8         |
| 39        | 5544.2         |
| 40        | 5325.0         |
| 41        | 5115.6         |
| 42        | 4915.6         |
| 43        | 4724.4         |

| Temp °C | Ohms   |
|---------|--------|
| 44      | 4541.7 |
| 45      | 4367.0 |
| 46      | 4200.0 |
| 47      | 4040.2 |
| 48      | 3887.4 |
| 49      | 3741.1 |
| 50      | 3601.1 |
| 51      | 3467.0 |
| 52      | 3338.7 |
| 53      | 3215.8 |
| 54      | 3098.0 |
| 55      | 2985.2 |
| 56      | 2877.0 |
| 57      | 2773.3 |
| 58      | 2673.9 |
| 59      | 2578.6 |
| 60      | 2487.1 |
| 61      | 2399.4 |
| 62      | 2315.2 |
| 63      | 2234.4 |
| 64      | 2156.8 |
| 65      | 2082.3 |
| 66      | 2010.8 |
| 67      | 1942.1 |
| 68      | 1876.0 |
| 69      | 1812.6 |
| 70      | 1751.6 |
| 71      | 1693.0 |
| 72      | 1636.6 |
| 73      | 1582.4 |
| 74      | 1530.2 |
| 75      | 1480.1 |
| 76      | 1431.8 |
| 77      | 1385.3 |
| 78      | 1340.6 |
| 79      | 1297.5 |
| 80      | 1256.1 |
| 81      | 1216.1 |
| 82      | 1177.7 |
| 83      | 1140.6 |
| 84      | 1104.9 |
| 85      | 1070.5 |

| Temp °C | Ohms   |
|---------|--------|
| 86      | 1037.3 |
| 87      | 1005.3 |
| 88      | 974.4  |
| 89      | 944.7  |
| 90      | 916.0  |
| 91      | 888.3  |
| 92      | 861.5  |
| 93      | 835.8  |
| 94      | 810.9  |
| 95      | 786.8  |
| 96      | 763.6  |
| 97      | 741.2  |
| 98      | 719.5  |
| 99      | 698.6  |
| 100     | 678.4  |
| 101     | 658.9  |
| 102     | 640.0  |
| 103     | 621.8  |
| 104     | 604.1  |
| 105     | 587.1  |
| 106     | 570.6  |
| 107     | 554.6  |
| 108     | 539.2  |
| 109     | 524.3  |
| 110     | 509.8  |
| 111     | 495.9  |
| 112     | 482.3  |
| 113     | 469.2  |
| 114     | 456.5  |
| 115     | 444.2  |
| 116     | 432.3  |
| 117     | 420.8  |
| 118     | 409.7  |
| 119     | 398.8  |
| 120     | 388.4  |
| 121     | 378.2  |
| 122     | 368.3  |
| 123     | 358.8  |
| 124     | 349.5  |
| 125     | 340.6  |

### Mounting recommendations using Au Sn eutectic solders

Recommended eutectic gold-tin alloy is 80%Au/20%Sn with a melt point of +280°C (556°F). High thermal conductivity of 80%Au/20%Sn solders increases the responsiveness of the NTC gold thermistor.

- Max ramp rate of 40°C per minute to a preheat temperature of +180°C to +200°C
- Preheat dwell period of 90 – 150 seconds @ +180°C to +200°C
- Maximum time above the eutectic temperature of +280°C for 45 seconds with a bell-shaped profile — no plateau at peak temperature of +300°C to +305°C
- Maximum time above peak temperature of +300°C for 8 seconds.
- Max cooling rate of 40°C per minute or less to prevent thermal stress on the component.
- Times indicated are based on the NTC surface temperature.

Excessive soldering temperatures and durations can cause leaching of the termination resulting in changes to the electrical characteristics of the NTC caused by reduction in adherence strength. The recommended profile is provided as a guideline only and it is recommended the customer validates the suitability for the intended purpose.

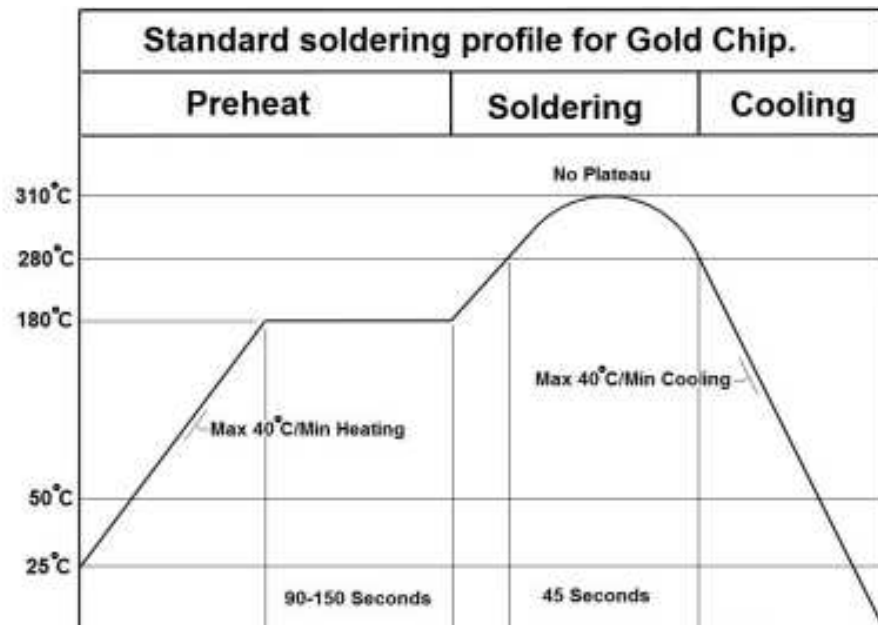



## GOLD CHIP THERMISTOR GA10K3CG582

### Ordering information

| Part Number | Description          | Resistance @ +25°C | MOQ  |
|-------------|----------------------|--------------------|------|
| GA10K3CG582 | Gold Chip Thermistor | 10,000             | 400* |

\*For orders less than MOQ, contact Sales

[CLICK HERE >](#)

**CONNECT WITH A SPECIALIST**

#### NORTH AMERICA

Tel +1 800 522 6752

#### EUROPE

Tel +31 73 624 6999

#### ASIA

Tel +86 0400 820 6015

### [te.com/sensors](https://te.com/sensors)

TE Connectivity, TE, TE Connectivity (logo) and Every Connection Counts are trademarks. All other logos, products and/or company names referred to herein might be trademarks of their respective owners

The information given herein, including drawings, illustrations and schematics which are intended for illustration purposes only, is believed to be reliable. However, TE Connectivity makes no warranties as to its accuracy or completeness and disclaims any liability in connection with its use. TE Connectivity's obligations shall only be as set forth in TE Connectivity's Standard Terms and Conditions of Sale for this product and in no case will TE Connectivity be liable for any incidental, indirect or consequential damages arising out of the sale, resale, use or misuse of the product. Users of TE Connectivity products should make their own evaluation to determine the suitability of each such product for the specific application.

© 2021 TE Connectivity Corporation. All Rights Reserved.

Version # 05/2021

