

F58Sxx

Hall Effect Zero Speed Sensor

Product ID

Type #	Product #	Drawing #
F58S	385Z-05332	113626
F58S25	385Z-05562	113626
F58S40	385Z-05563	113626

General

Function The F58Sxx series Hall effect speed sensors are suitable, in conjunction with a ferrous pole wheel, for generating square wave signals proportional to rotary speeds and direction signals. They exhibit a static function, whereby pulse generation down to 0 Hz is guaranteed. The sensor function is independent of rotational mounting angle.

Technical data

Supply voltage	8...25 VDC
Current consumption	Max. 12 mA (without load)
Signal output	Square wave signal from NPN output transistor with internal 2.7 kOhm pull-up resistor, DC coupled to supply (negative pole = reference Voltage). <ul style="list-style-type: none"> • Sink current: max. 25 mA • Output voltage: <ul style="list-style-type: none"> • Uhigh ~ supply voltage • Ulow < 0.5 V at I = 25 mA
Frequency range	0 Hz...15 kHz
Housing	5/8"-18 UNF-2A. tightening torque: max. 35 Nm
Connection	Cable with open leads: 3-wire, 3 x 0.34 mm ² (AWG22), stranded wires, elastomer isolation, green casing, fire retardant, low smoke, RoHS conform and halogen free, max. outer Ø = 4.8 mm, min. bending radius = 25 mm (static) and 50 mm (dynamic), cable length according to dimensional drawing
Protection	Sensor head: IP68 Connector: IP67
Insulation	Housing and electronics galvanically isolated (Test: 500 V, 50 Hz for 1 minute)

Pole wheel	Prerequisite: Toothed wheel of a ferrous material (e.g. Steel 1.0036). Optimal performance with <ul style="list-style-type: none"> * Involute gear * Tooth width > 10mm * Side offset < 0.2 mm * Eccentricity <0.2 mm
Air gap between sensor and pole wheel	<ul style="list-style-type: none"> * Module 1.0 (DP 25.4): 0.3...0.5 mm * Module 2.0 (DP 12.7): 0.3...1.5 mm
Operating temperature	-40°C...+125°C

Further Information

Safety	All mechanical installations must be carried out by an expert. General safety requirements have to be met.
Connection	<p>Sensor wires are susceptible to radiated noise. Therefore, the following points have to be considered when connecting a sensor:</p> <p>The sensor wires must be laid as far as possible from large electrical machines. They must not run parallel in the vicinity of power cables.</p> <p>The maximum permissible cable length is dependent upon the sensor voltage, the cable routing, along with cable capacitance and inductance. However, it is advantageous to keep the distance between sensor and instrument as short as possible. The sensor cable may be lengthened via a terminal box located in an IP20 connection area in accordance with EN 60529.</p>
Installation	<p>The sensor has to be aligned to the pole wheel according to the sensor drawing independent of its rotational orientation. Deviations in positioning may affect the performance and decrease the noise immunity of the sensor. During installation, the smallest possible pole wheel to sensor gap should be set. The gap should however be set to prevent the face of the sensor ever touching the pole wheel. Within the air gap specified the amplitude of the output signal is not influenced by the air gap.</p> <p>A sensor should be mounted with the middle of the face side over the middle of the pole wheel. Dependent upon the wheel width, a certain degree of axial movement is permissible. However, the middle of the sensor must be at minimum in a distance of 3 mm from the edge of the pole wheel under all operating conditions.</p> <p>A solid and vibration free mounting of the sensor is important. Eventual sensor vibration relative to the pole wheel can induce additional output pulses.</p> <p>The sensors are insensitive to oil, grease etc. and can be installed in arduous conditions. Within the air gap specified the amplitude of the output signals is not influenced by the air gap.</p>
Maintenance	Product cannot be repaired.
Transport	Product must be handled with care to prevent damage of the front face.
Storage	Product must be stored in dry conditions. The storage temperature corresponds to the operation temperature.
Disposal	Product must be disposed of properly, it must not be disposed as domestic waste.

F58Sxx

Hall Effect Zero Speed Sensor

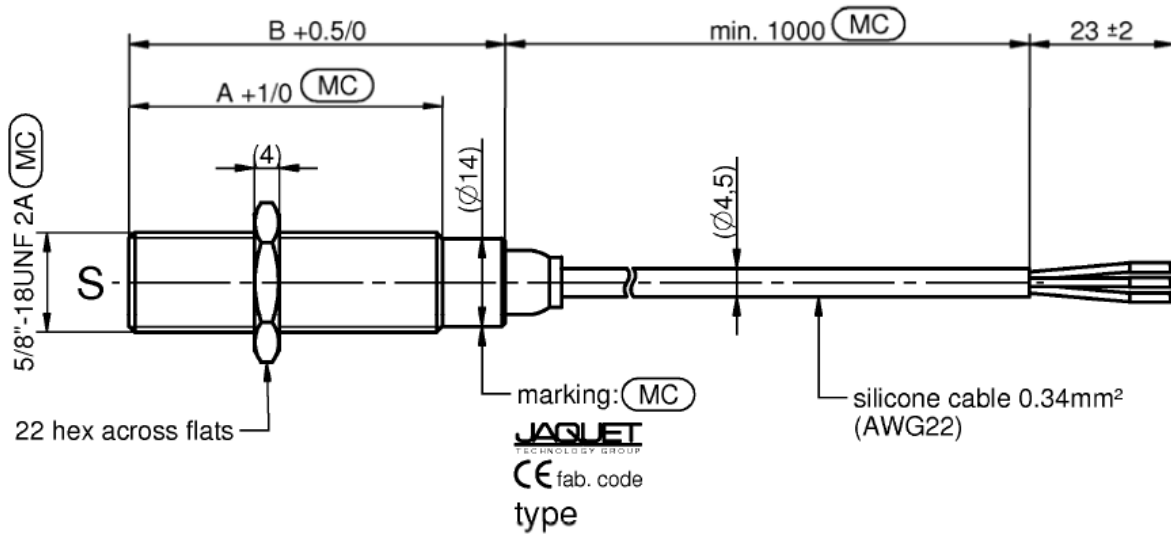

part no.	Jaquet	A	B
385Z-05332	F58S	50	60
385Z-05562	F58S25	64	74
385Z-05563	F58S40	102	112

connecting diagram:

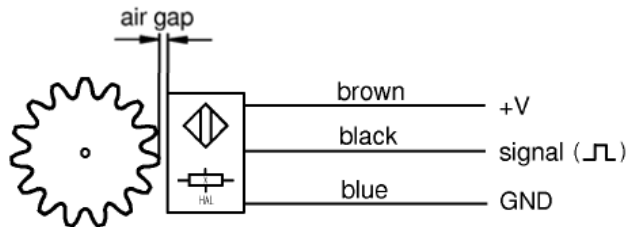

FOR TECHNICAL SPECIFICATIONS SEE OPERATING INSTRUCTIONS

- (CC) Critical characteristic
- (MC) Major characteristic

Dimensions in mm

CONTACT US

Tel +41 61 306 8822

jaquet.info@te.com

te.com/sensorsolutions

JAQUET, TE Connectivity, and TE connectivity (logo) are trademarks. All other logos, products and/or company names referred to herein might be trademarks of their respective owners.

The information given herein, including drawings, illustrations and schematics which are intended for illustration purposes only, is believed to be reliable. However, TE Connectivity makes no warranties as to its accuracy or completeness and disclaims any liability in connection with its use. TE Connectivity's obligations shall only be as set forth in TE Connectivity's Standard Terms and Conditions of Sale for this product and in no case will TE Connectivity be liable for any incidental, indirect or consequential damages arising out of the sale, resale, use or misuse of the product. Users of TE Connectivity products should make their own evaluation to determine the suitability of each such product for the specific application.

© 2017 TE Connectivity Ltd. family of companies All Rights Reserved.