



SSRA series

2A Miniature, SIP Solid State Relay With Paired SCR Output

File E29244

Users should thoroughly review the technical data before selecting a product part number. It is recommended that users also seek out the pertinent approvals files of the agencies/laboratories and review them to confirm the product meets the requirements for a given application.

Features

- Miniature SIP package permits high density population of PC board.
- 2A rms inverse-parallel connected SCR output.
- 4-10 VDC input control.
- Zero voltage and random voltage turn-on versions.
- 2500V rms optical isolation.

Engineering Data

Form: 1 Form A (SPST-NO).
 Duty: Continuous.
 Isolation: 2500V rms input-to-output-to-ground.
 Insulation Resistance: 10⁹ Ohms, minimum, at 500VDC.
 Capacitance: 8.0 pf maximum (input to output).
 Temperature Range:
 Storage: -30°C to +125°C
 Operating: -30°C to + 80°C
 Case Material: Thermally conductive epoxy encapsulation.
 Case and Mounting: Refer to outline dimension drawing.
 Termination: Printed circuit terminals. Refer to outline dimension drawing.
 Approximate Weight: .15 oz. (4.3g).

Ordering Information

Product code structure	Typical product code	SSRA	-240	D	2	R
Basic Series SSRA Miniature SIP Solid State Relay						
Line Voltage 240 12 - 280 VAC						
Input Type & Voltage D 4 - 10 VDC						
Maximum Switching Rating / Output 2 2.0A rms						
Options Blank Zero voltage turn-on R Random voltage turn-on						

Our authorized distributors are more likely to maintain the following items in stock for immediate delivery.

SSRA-240D2
 SSRA-240D2R

Input Specifications

Parameter	Conditions	Units	Zero V or Random V Turn-on Units
Control Voltage Range V _{IN}	@ 25°C	VDC	4-10
Must Operate Voltage V _{IN(OP)} (Min.)	@ 25°C	VDC	4
Must Release Voltage V _{IN(REL)} (Min.)	@ 25°C	VDC	1
Input Current @ 5 VDC (Typ.)	@ 25°C	mA DC	15
Input Impedance (Nom.)	@ 25°C	ohms	300

Output Specifications (@ 25° C, unless otherwise specified)

Parameter	Conditions	Units	
Load Voltage Range V_L	$f = 47 - 63 \text{ Hz.}$	V rms	12 - 280
Repetitive Blocking Voltage (Min.)		V peak	± 600
Load Current Range I_L^*		A rms	.06 - 2.0
Single Cycle Surge Current (Min.)		A peak	120
Leakage Current (Off-State) (Max.)	$f = 60 \text{ Hz. } V_L = 280\text{Vrms}$	mA rms	0.1
On-State Voltage Drop (Max.)	$I_L = \text{Max.}$	V peak	1.5
Static dv/dt (Off-State) (Min.)	$V_L = \text{Max.}$	V/ μs	500
Turn-On Time (Max.)	$f = 60 \text{ Hz.}$	ms	8.3 for Zero Voltage Turn-On Models 0.1 for Random Voltage Turn-On Models
Turn-Off Time (Max.)	$f = 60 \text{ Hz.}$	ms	8.3
Load Power Factor Rating (Min.)	$I_L = \text{Max.}$		0.5

*see Thermal Derating Curves

Electrical Characteristics (Thermal Derating Curve)

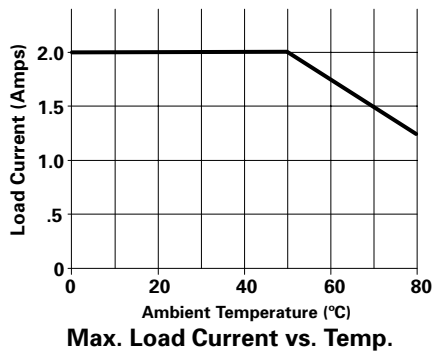

Outline Dimensions

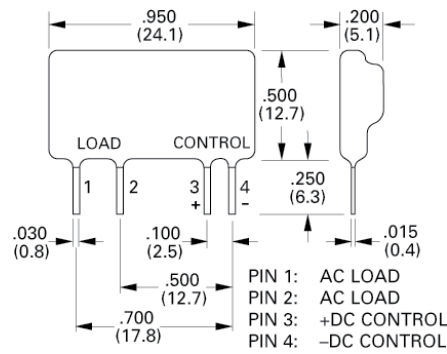

Product Code	Part Number
SSRA-240D2	5-1393030-6
SSRA-240D2R	5-1393030-7

Disclaimer

While TE has made every reasonable effort to ensure the accuracy of the information in this document, TE does not guarantee that it is error-free, nor does TE make any other representation, warranty or guarantee that the information is accurate, correct, reliable or current.

TE reserves the right to make any adjustments to the information contained herein at any time without notice. TE EXPRESSLY DISCLAIMS ALL IMPLIED WARRANTIES REGARDING THE INFORMATION CONTAINED HEREIN, INCLUDING, BUT NOT LIMITED TO, ANY IMPLIED WARRANTIES OF MERCHANTABILITY OR FITNESS FOR A PARTICULAR PURPOSE.

The dimensions in this catalog are for reference purposes only and are subject to change without notice. Specifications are subject to change without notice. Consult TE for the latest dimensions and design specifications.

To view Solid-State relay application notes click here