



## VERTICAL LIQUID LEVEL SWITCHES

### VS Series

High- or low-level switching

N.O./N.C. SPST or SPDT outputs

Mounted on the top/bottom wall of a tank

Certified reed switch (UL component listed)

Many different configurations available

#### Features

- Voltage rating up to 250VAC
- Current rating up to 1.0 amp
- Compact design and low profile
- Optional cable lengths
- Includes mounting hardware

#### Applications

- Water and fuel storage tanks
- Full and/or empty detection
- Pump on/off controls
- Marine bilge and ballast tanks
- Flood detection and prevention
- Coolant level indication
- Livestock watering tanks
- Irrigation systems
- Water treatment plants
- Waste water tanks

The VS series of point liquid level switches demonstrates a high degree of reliability due to the use of non-reactive wetted components and a unique reed switch designed specifically for level sensing applications. The sensor utilizes a moving float with an embedded magnet to activate a reed switch located in the sensor body. As the liquid level raises the float, it moves into close proximity to the reed switch and actuates it to give an open contact or closed contact switch indication.

The reliability of this sensor results from a very simple operating principle, a single moving part, media compatible wetted materials, and a unique reed switch design that has a UL recognized component certification.

The sensor mounts into the top or bottom wall of a liquid storage tank using either a 1/2" NPT or M16 x 2.0 threaded fitting. The M16 mount is available in either an internal or external configuration. The output is a simple N.O. or N.C. SPST, or SPDT reed switch that utilizes Ruthenium contact points for reliability. Changing from a N.O. output to a N.C. output is done by removing the float and reattaching it in an inverted orientation. This change can be done in the field. Electrical outputs are a single pair or three wires with PVC insulation and optional lengths of 0.5 m or 2.0 m.

[CLICK HERE >](#)  
**CONNECT WITH A SPECIALIST**

## LIQUID LEVEL SWITCH

VS SERIES

### Absolute Maximum Ratings <sup>(1)</sup>

Parameter	Model Type	Min	Max	Units	Notes/Conditions
DC contact voltage (SPST)	VSx01		100	V	Do not exceed 15W
DC contact current (SPST)			1	A	
RMS contact voltage (SPST)			120	V	
RMS contact current (SPST)			1	A	
DC contact voltage (SPST)	VSx09		200	V	Do not exceed 70W
DC contact current (SPST)			1.0	A	
RMS contact voltage (SPST)			250	V	
RMS contact current (SPST)			1.0	A	
DC contact voltage (SPDT)	VSx04		170	V	Do not exceed 5.0W
DC contact current (N.O. SPDT)			0.4	A	
DC contact current (N.C. SPDT)			0.125	A	
RMS contact voltage (SPDT)			125	V	
RMS contact current (SPDT)			0.125	A	
Operating and storage temperature		-30	130	°C	
Fitting pressure		-1.0	4.7	Bar	Internal tank pressure
Tank wall thickness (Internal mount)		1.0	10	mm	
Tank wall thickness (External mount)		1.0	4.0	mm	

<sup>(1)</sup> Maximum limits the device will withstand without damage

## LIQUID LEVEL SWITCH

VS SERIES

---

### Product Specifications

Parameter	Details & Options
Mounting Orientation	Top/bottom entry
Fitting	Internal or External
Switch Operation	N.C. when float at bottom stop (SPST) N.O. when float is inverted (SPST)
Contact Forms	Form A (SPST) or Form C (SPDT)
Contact Material	Ruthenium
Contact resistance (max)	250 mΩ (SPST)
Housing and Float Material	Glass filled nylon 6.6 (better for oil, fuel, non-ionic liquids) Glass filled polypropylene (better for aqueous media and solutions)
Cable Description	22 AWG 16/0.2mm PVC insulated, UL/CSA/BS6361
Shock	±50g 11ms half sign duration
Vibration	±35g 0 – 500Hz
Ambient Humidity	0 – 95% RH (non-condensing)
Ingress Protection	IP68 (wetted surfaces) IP65 (non-wetted surfaces)
Approvals & Certifications	UL file E98428

# LIQUID LEVEL SWITCH

VS SERIES

## Outline Dimensions

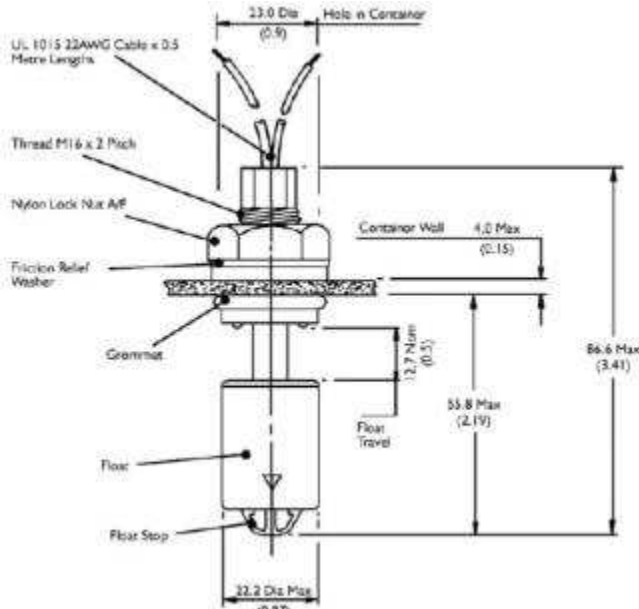

### EXTERNAL FITTING

CONTAINER WALL (THICKNESS MAX 4mm, MIN 1mm)

NOTE! DRILL 0.9" OR 23mm HOLE, ENSURE FREE FROM SWarf AND SHARP EDGES.

SEALING GROMMET

FRICITION RELIEF WASHER

FIXING NUT

NOTE! MAX TORQUE 2lbs/ft OR 2.67Nm.

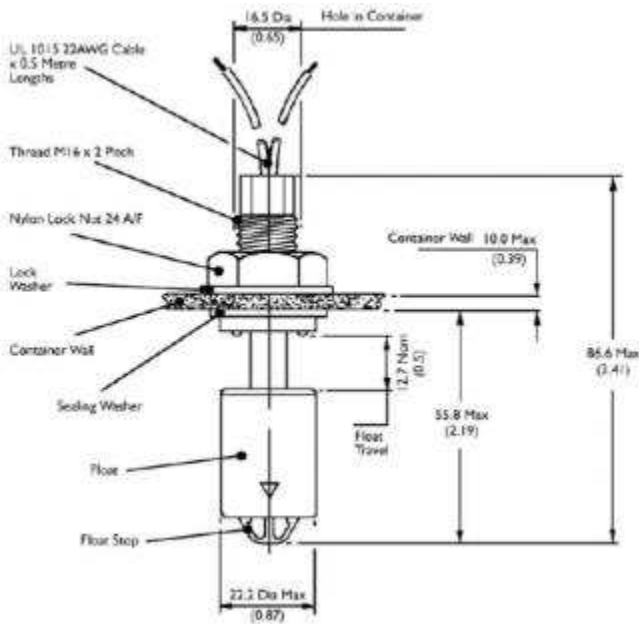
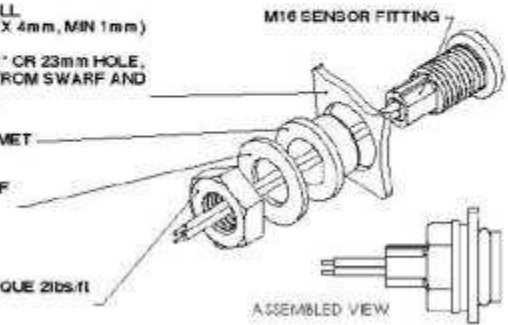

### INTERNAL FITTING

CONTAINER WALL (THICKNESS MAX 10mm, MIN 1mm)

NOTE! DRILL 0.65" OR 16.5mm HOLE, ENSURE FREE FROM SWarf AND SHARP EDGES.

LOCK WASHER

FIXING NUT

NOTE! MAX TORQUE 3lbs/ft OR 4Nm.

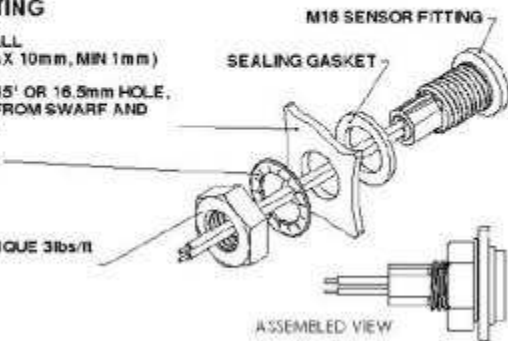

## Schematic

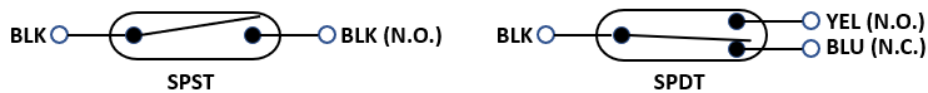

Switch position with no magnet present

# LIQUID LEVEL SWITCH

VS SERIES

## Mounting Orientations

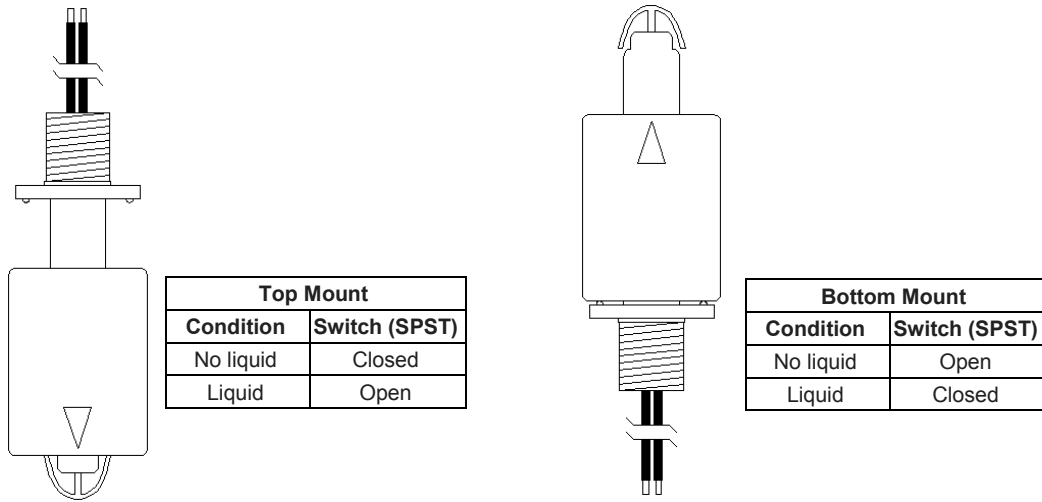

## Application Information

The versatile design of the VCS series level sensor provides four different mounting and operating modes. The sensor can mount at either the top or bottom of a liquid storage tank. In either position, the float can be oriented to provide a N.O. or N.C. contact. Because the magnet is positioned at one end of the float, it can be removed from the body, turned upside down, and reinstalled to provide any of the four configurations shown below.

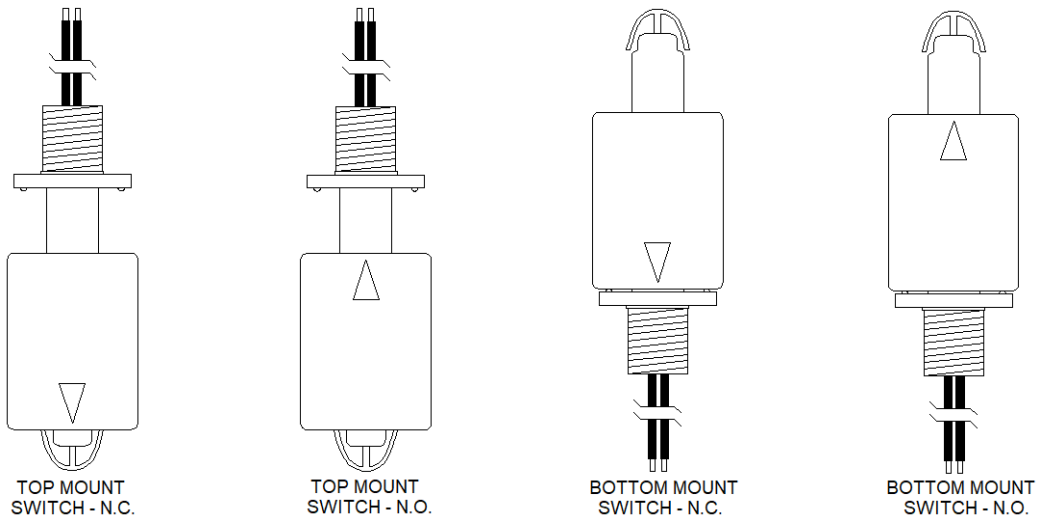

To remove and re-orient the float, gently squeeze the retainer clips at the end of the sensor and slide the float off the body. Reinstall the float by sliding it back over the stem ensuring that it passes the clips and allows them to return to their original position.

# LIQUID LEVEL SWITCH

VS SERIES

## Ordering Information

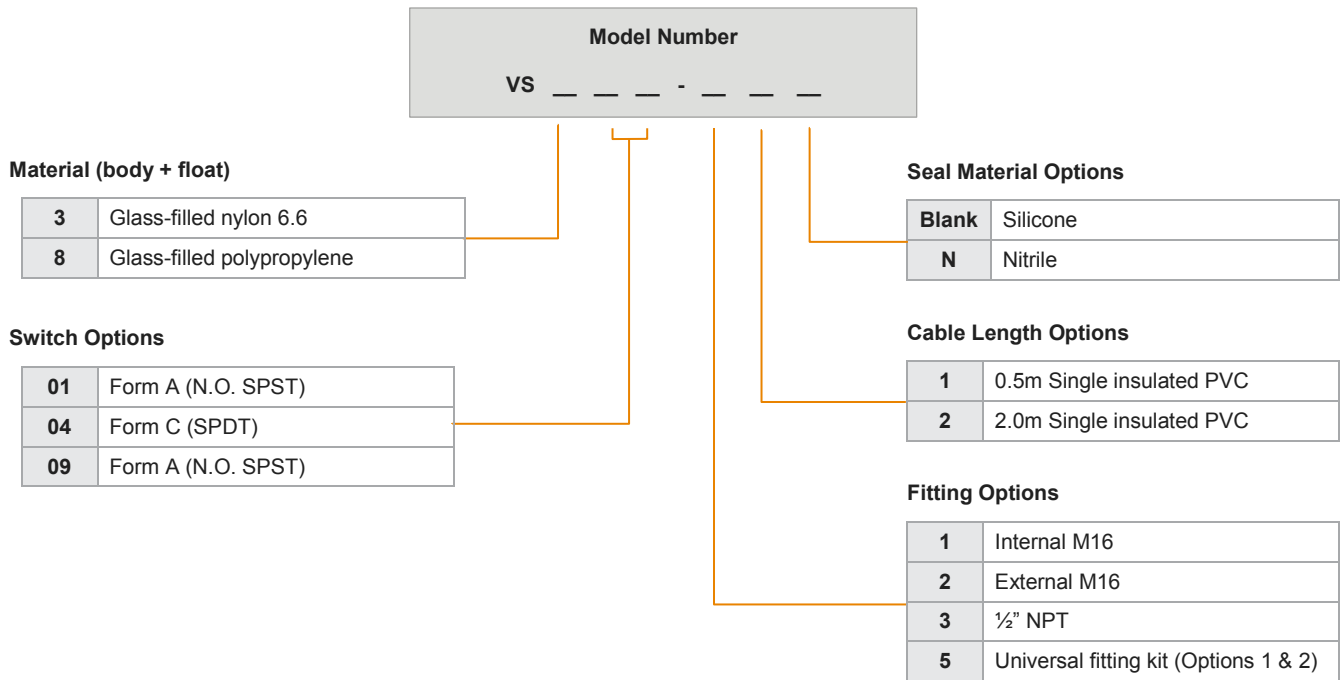

[CLICK HERE >](#)  
**CONNECT WITH A SPECIALIST**

**NORTH AMERICA**  
Tel +1 800 522 6752

**EUROPE**  
Tel +31 73 624 6999

**ASIA**  
Tel +86 0400 820 6015

## [te.com/sensors](https://te.com/sensors)

TE Connectivity, TE, TE Connectivity (logo) and Every Connection Counts are trademarks. All other logos, products and/or company names referred to herein might be trademarks of their respective owners

The information given herein, including drawings, illustrations and schematics which are intended for illustration purposes only, is believed to be reliable. However, TE Connectivity makes no warranties as to its accuracy or completeness and disclaims any liability in connection with its use. TE Connectivity's obligations shall only be as set forth in TE Connectivity's Standard Terms and Conditions of Sale for this product and in no case will TE Connectivity be liable for any incidental, indirect or consequential damages arising out of the sale, resale, use or misuse of the product. Users of TE Connectivity products should make their own evaluation to determine the suitability of each such product for the specific application.

© 2020 TE Connectivity Corporation. All Rights Reserved.

10/2020