











PART NUMBER	REV	FIRST USED	TERMINALS APPLIED
1852892-1	A	AOM / CLS	520971, 521583, SUPERSEDED BY 1852892-4
1852892-2	A	K UNIT	1969109, 1969283 SUPERSEDED BY 1852892-4
1852892-3	A	G UNIT	521282, 521716, 521347 SUPERSEDED BY 1852892-4
1852892-4	B	AOM / CLS	520971, 521583, 1969109, 1969283, 521282, 521716, 521347, 521087  SUPERSEDED BY 1852892-4
1852892-5	A	K UNIT	SUPERSEDED BY 1852892-4
1852892-6	A	G UNIT	SUPERSEDED BY 1852892-4
1852892-7	A	KOMAX	520971, 521282, 521583, 521716, 521347, 1969109, 1969283  OBSOLETE
7-1852892-7	A	SPARE PARTS KIT	

CRIMPING DATA				
PAD LETTER	CRIMP HEIGHT	WIRE SIZE	STRIP LENGTH	
A	.070	#14	.281	
B	.061	#16		
C	.055	#18		
D	NOT USED		-	
CRIMP WIRE	SIZE	TYPE	FEED	TERM APPL SPEC
	.110	F	.740	114-2124
INSUL RANGE	WIRE RANGE	APPLICATOR INSTRUCTION SHEET		
.110-.160	18 -14	AI 8099 AI 8102		

REVISIONS				
P	LTR	DESCRIPTION	DATE	BY
B		REVISED PER ECR-24-210726	05JUN2024	GV

-  RECOMMENDED SPARE PARTS.
-  ITEMS NOT SHOWN ON ASSEMBLY.
-  TOLERANCE ON CUT LENGTH TO BE ±.13.
-  USED ON THE CLS I AND II MACHINES ONLY. REMOVE THE TWO MOUNTING SCREWS SECURING THE PRODUCT DEREELEER AND PLACE THE PRODUCT GUIDE (ITEM 111) ON TOP OF THE MOUNTING BRACKET. REASSEMBLE AND RETIGHTEN THE TWO MOUNTING SCREWS.
-  ITEM 127 "T" TERMINATING UNIT CONVERSION KIT 856399-1 CONVERTS APPLICATOR 852500-2 TO A 852500-1.
-  ITEM 128 AOM 4A FEED SIDE CONVERSION KIT 856875-1 CONVERTS AN AOM TO RUN APPLICATOR 852500-1.
-  ITEM 129 "K" TERMINATING UNIT CONVERSION KIT 856398-1 CONVERTS APPLICATOR 852500-1 TO A 852500-2.
-  ADJUSTING THE VALVES (ITEMS 40 AND 47).

8a. FOR 852500-1 ASSEMBLY ONLY.

MAKE SURE THE CAM VALVE (ITEM 84) IS IN THE FULLY DOWN POSITION BEFORE PLACING THE RAM BACK INTO THE APPLICATOR. INSTALL THE APPLICATOR INTO A "T" TERMINATING UNIT, TURNING THE POWER TO THE UNIT OFF WHILE ALLOWING THE AIR TO REMAIN ON. MANUALLY CYCLE THE UNIT, PRODUCT MUST NOT BE PRESENT IN THE APPLICATOR, SO THAT THE RAM IS AT DEAD BOTTOM OF ITS STROKE. LOOSEN THE FOUR SCREWS SECURING THE VALVES (ITEMS 40 AND 47) AND SLOWLY RAISE THE RAM UPWARD UNTIL THE INSULATION CRIMPER LEG (ITEM 78) IS IN THE CENTER OF THE INSERTER (ITEM 18). ADJUST THE LOWER VALVE (ITEM 47) SO IT IS ON THE LOWER LOBE OF THE CAM VALVE (ITEM 84) AND IS ACTUATED, THEN RETIGHTEN THE TWO MOUNTING SCREWS. THIS VALVE WILL CAUSE THE INSERTION CYLINDER TO EXTEND, INSERTING THE HOUSING ONTO THE TERMINATED PRODUCT.

CONTINUE RAISING THE RAM, STOPPING JUST BEFORE TOP DEAD CENTER. NOW POSITION THE UPPER VALVE (ITEM 40) SO IT IS ON THE UPPER LOBE OF THE VALVE CAM (ITEM 84) AND IS ACTUATED, THEN RETIGHTEN THE TWO MOUNTING SCREWS. THIS VALVE WILL CAUSE THE INSERTION CLYINDER TO RETRACT AFTER THE HOUSING IS APPLIED. COMPLETE THE THE UNIT CYCLE TO TOP DEAD CENTER.

CHECK THE ADJUSTMENTS JUST MADE BY PUTTING PRODUCT INTO THE APPLICATOR AND CYCLING THE UNIT UNDER POWER A FEW TIMES AND VARIFY THAT THE CURRENT SETTINGS ARE CORRECT. IF ADJUSTMENTS MUST BE MADE TURN OFF POWER TO THE UNIT, REMOVE ANY PRODUCT AND FOLLOW THE STEPS ABOVE.

NOTE: UNDER MANUAL MODE DAMAGE TO THE HOUSINGS WILL OCCUR WHEN PRODUCT IS APPLIED TO THE APPLICATOR DUE TO TIMING, THIS IS AN ENGINEERED INTERFERENCE AND WILL BE CORRECTED UNDER POWER OF THE UNIT.







8b. FOR 852500-2 ASSEMBLY ONLY.

MAKE SURE THE CAM VALVE (ITEM 84) IS IN THE FULLY UP POSITION BEFORE PLACING THE RAM BACK INTO THE APPLICATOR. INSTALL THE APPLICATOR INTO A "K" TERMINATING UNIT, TURNING THE POWER TO THE UNIT OFF WHILE ALLOWING THE AIR TO REMAIN ON. MANUALLY CYCLE THE UNIT, PRODUCT MAY BE PRESENT IN THE APPLICATOR, SO THAT THE RAM IS AT DEAD BOTTOM OF ITS STROKE. LOOSEN THE FOUR SCREWS SECURING THE VALVES (ITEMS 40 AND 47) AND SLOWLY RAISE THE RAM UPWARD UNTIL THE INSULATION CRIMPER LEG (ITEM 78) CLEARS THE INSERTER BY .03±.03. ADJUST THE LOWER VALVE (ITEM 47) SO IT IS ON THE LOWER LOBE OF THE CAM VALVE (ITEM 84) AND IS ACTUATED, THEN RETIGHTEN THE TWO MOUNTING SCREWS. THIS VALVE WILL CAUSE THE INSERTION CYLINDER TO EXTEND, INSERTING THE HOUSING ONTO THE TERMINATED PRODUCT.

CONTINUE RAISING THE RAM, STOPPING JUST BEFORE TOP DEAD CENTER. NOW POSITION THE UPPER VALVE (ITEM 40) SO IT IS ON THE UPPER LOBE OF THE VALVE CAM (ITEM 84) AND IS ACTUATED, THEN RETIGHTEN THE TWO MOUNTING SCREWS. THIS VALVE WILL CAUSE THE INSERTION INSERTION CYLINDER TO RETRACT AFTER THE HOUSING IS APPLIED. COMPLETE THE THE UNIT CYCLE TO TOP DEAD CENTER.

CHECK THE ADJUSTMENTS WITH A FEW MANUAL CYCLES OF THE PRESS TO VARIFY CLEARANCES FOR THE TOOLING AND CONTINUING TO ADJUST THE VALVES UNTIL THESE CLEARANCES ARE OBTAINED.

-  THE CYLINDER MOUNT (ITEM 31) SHOULD BE ADJUSTED VERTICALLY SO THE INCOMING PRODUCT GOES THROUGH THE STRIP GUIDES (ITEMS 60 AND 95) AND INTO THE INSERTER (ITEM 18) WITHOUT ANY OBSTRUCTIONS TO DISLodge OR STUB ON THE HOUSINGS.

-  LOCATE THE REAR KEYS THAT LOCATE THE APPLICATOR TO THE TERMINATING UNIT BASE PLATE. THE SOCKET HEAD CAP SCREW SECURING THE KEY CLOSEST TO THE FRONT OF THE UNIT MUST BE REPLACED WITH A BUTTON HEAD CAP SCREW (ITEM 92 OR 107). THIS CHANGE WILL NOT EFFECT ANY OTHER APPLICATOR.
-  BUTTON HEAD CAP SCREW (ITEM 92 OR 107) IS TO BE BAGGED AND SHIPPED ALONG WITH THE APPLICATOR.
-  TERMINAL 521087 REQUIRES LUBRICATOR ASSY.
-  ADD SHIM BETWEEN POD INSERTER & HOUSING IF TERMINALS HIT POD INSERTER.
- 14. SPRING LOADED TONKER (P/N 354853-1) MUST BE USED WHEN RUNNING THE APPLICATOR ON A LEADMAKER.
-  AIR VALVE CONVERSION KIT, KOMAX 1633069-1 CONVERTS 852500-1 UP TO & INCLUDING REV N TO A 852500-7. AIR VALVE CONVERSION KIT, KOMAX 1633069-2 CONVERTS 852500-1 REV P THRU CURRENT TO A 852500-7.
-  GRIND BOTTOM OF ITEM 46 IF IT PROTRUDES BELOW BOTTOM OF ITEM 95.

THIS DRAWING IS A CONTROLLED DOCUMENT.		DIN M. YOUNGER 05OCT2012	 TE Connectivity Ltd.	
DIMENSIONS: INCHES		CHK T. ELBIN 05OCT2012		
		TOLERANCES UNLESS OTHERWISE SPECIFIED: 0. PLC ± - 1. PLC ± - 2. PLC ± - 3. PLC ± - 4. PLC ± - ANGLES ± -	NAME ULTRA-POD FLAG APPLICATOR PRODUCT SPEC - APPLICATION SPEC -	
MATERIAL -		FINISH -	SIZE A1 CAGE CODE 00779 DRAWING NO. 1852892 WEIGHT -	RESTRICTED TO -
CUSTOMER ACCESSIBLE PRODUCTION DRAWING			SCALE 1:1	SHEET 1 OF 3



REVISIONS				
P	LTR	DESCRIPTION	DATE	APVD
-	SEE SHEET 1		-	-

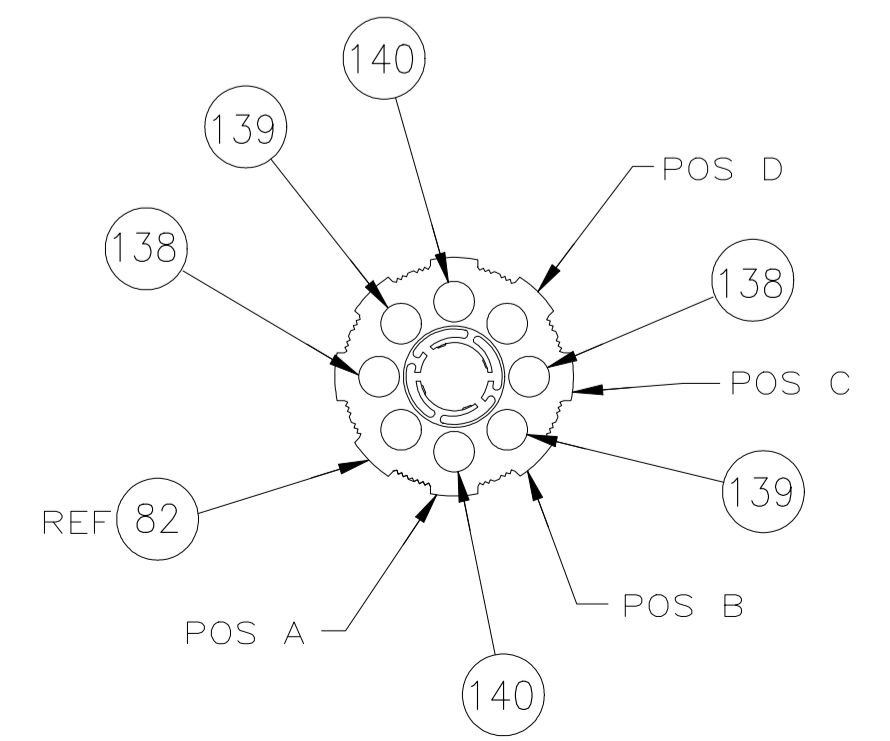
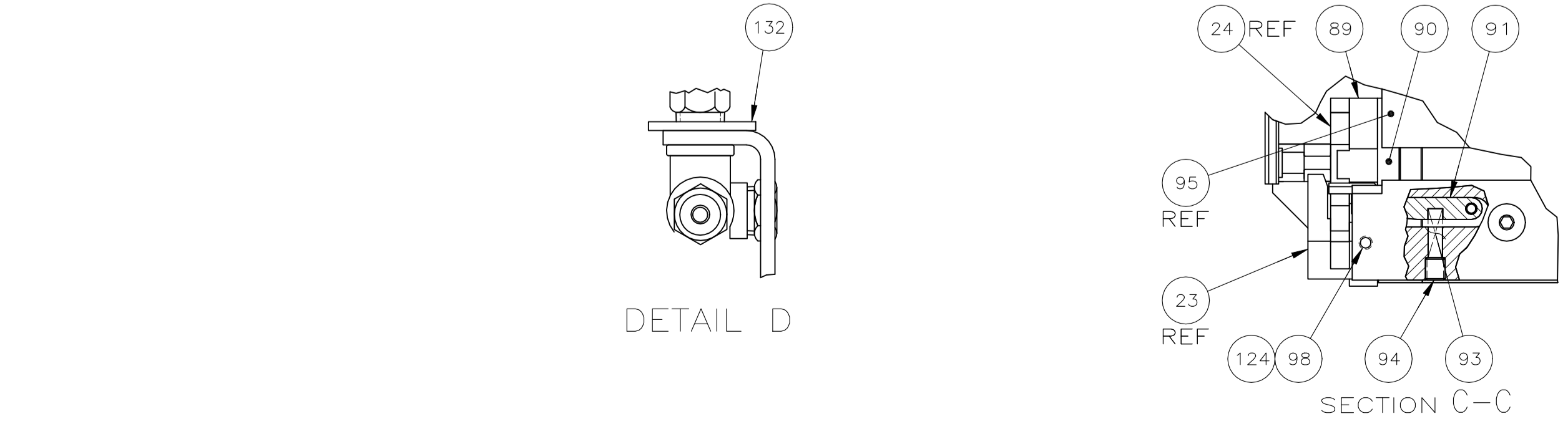
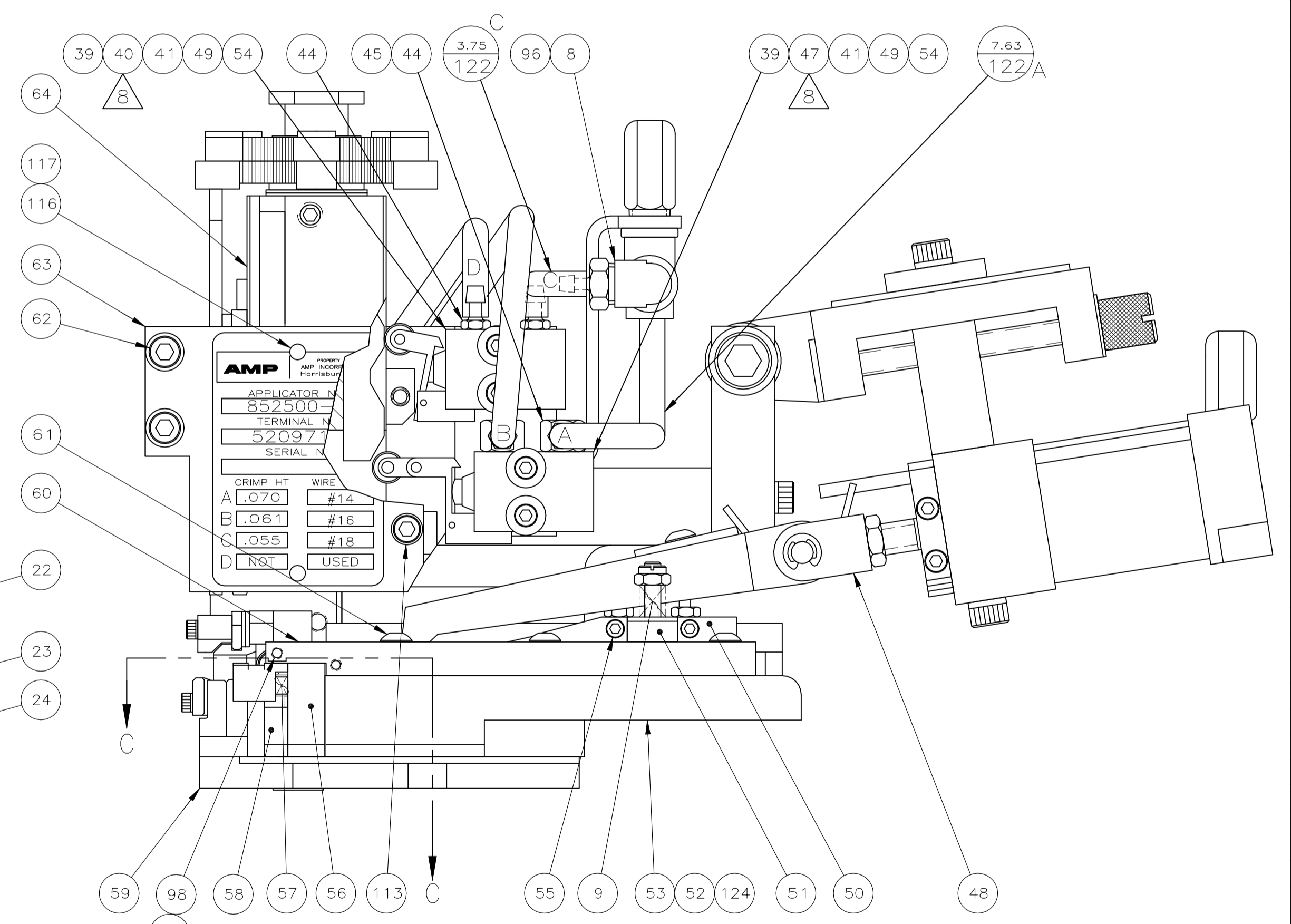
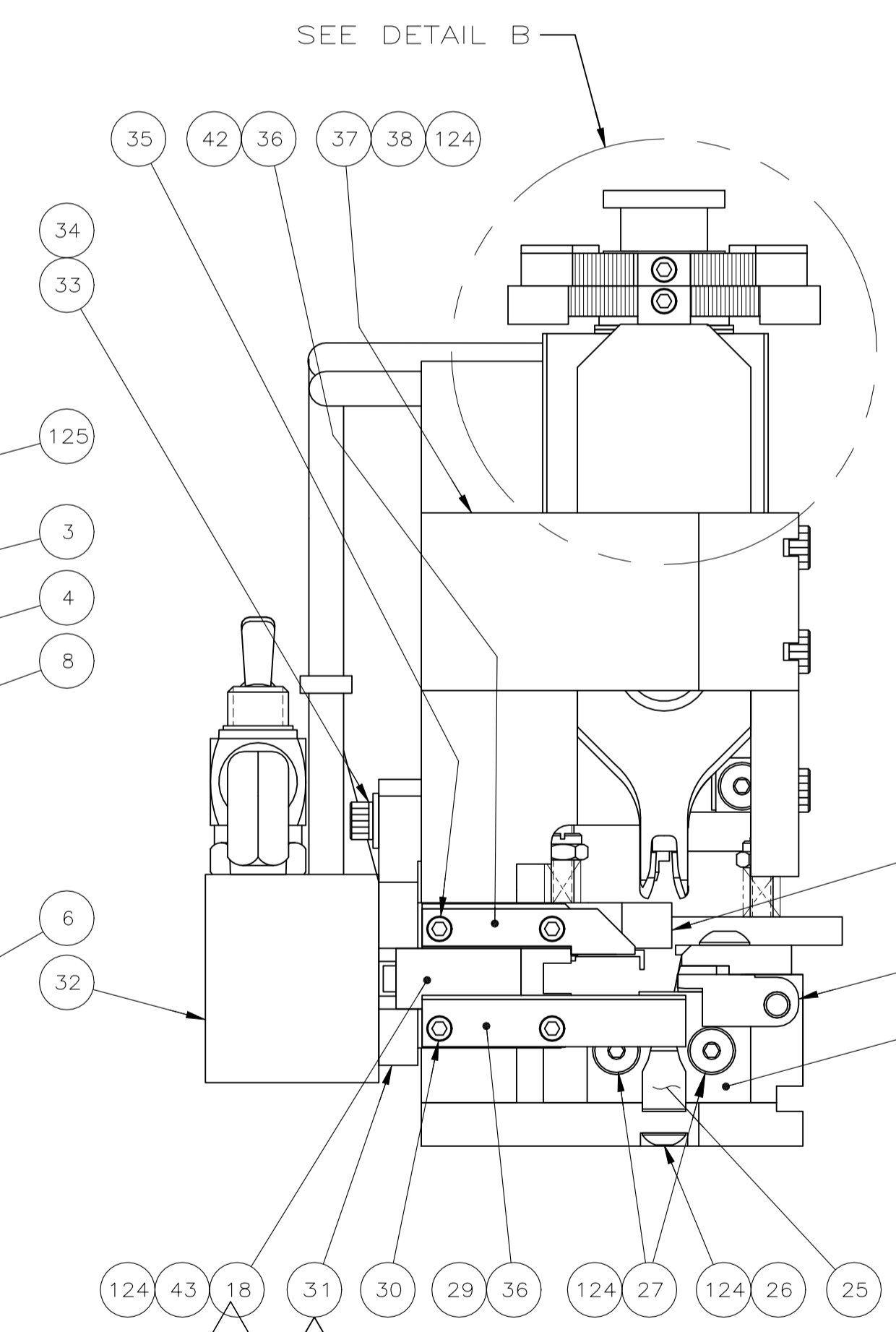
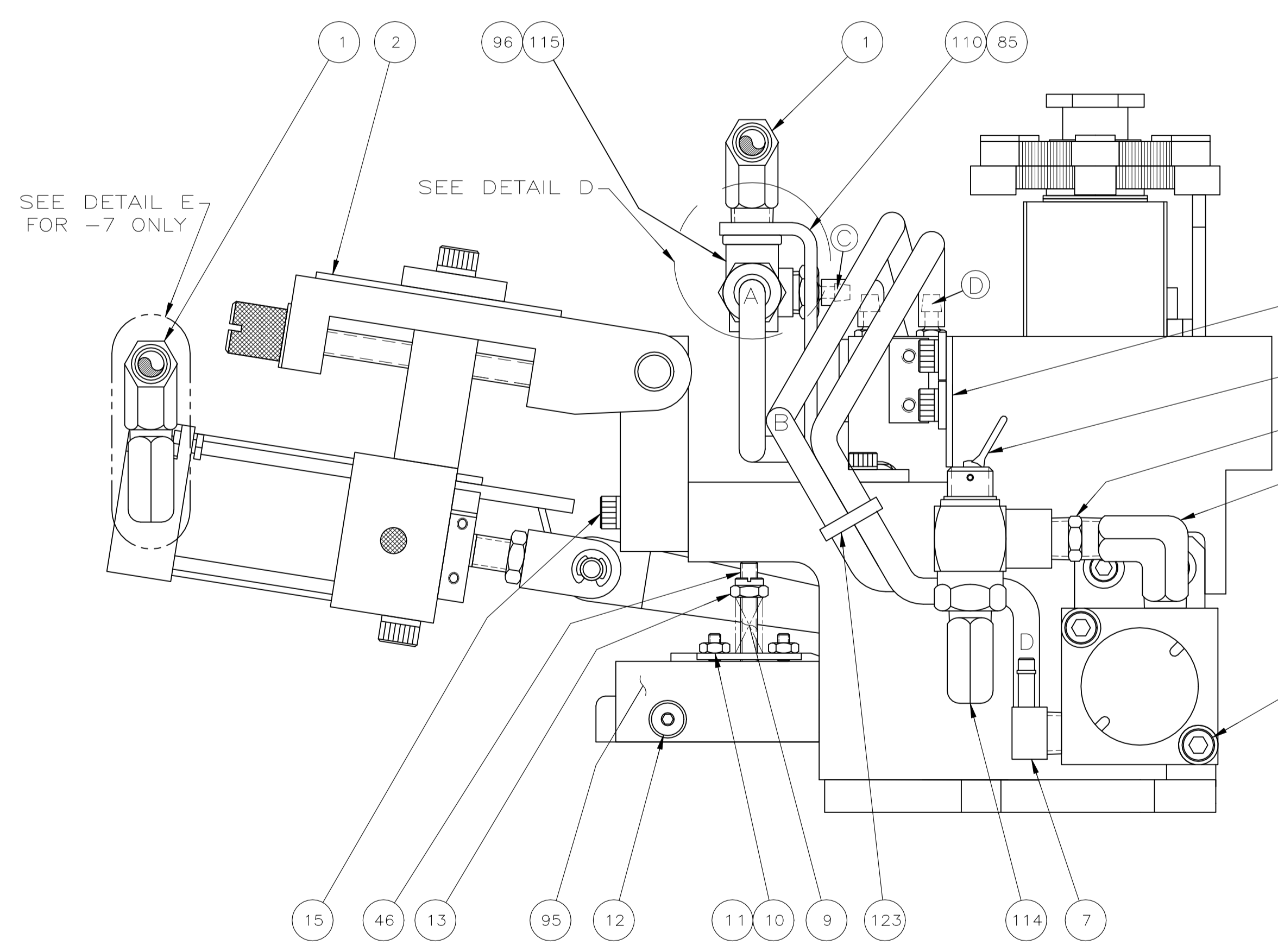
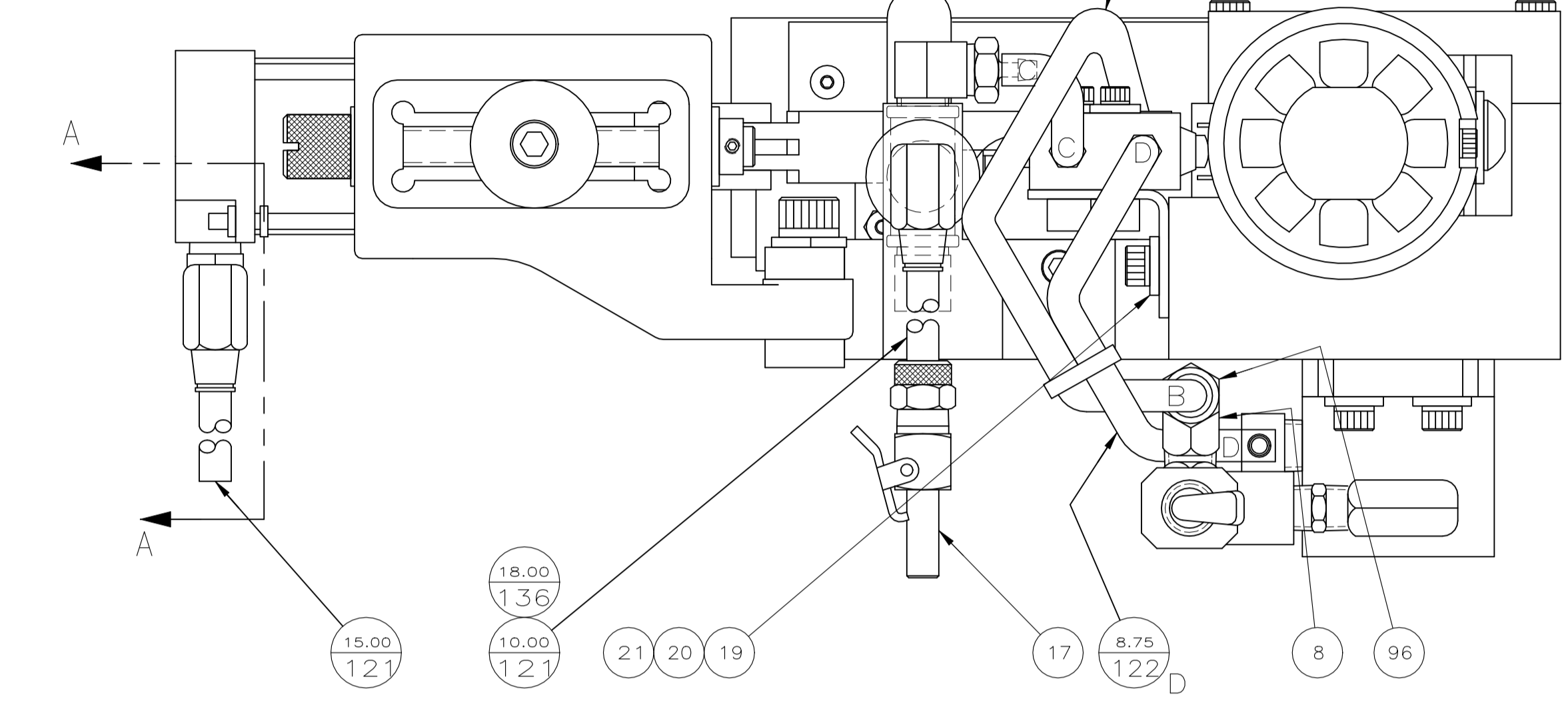
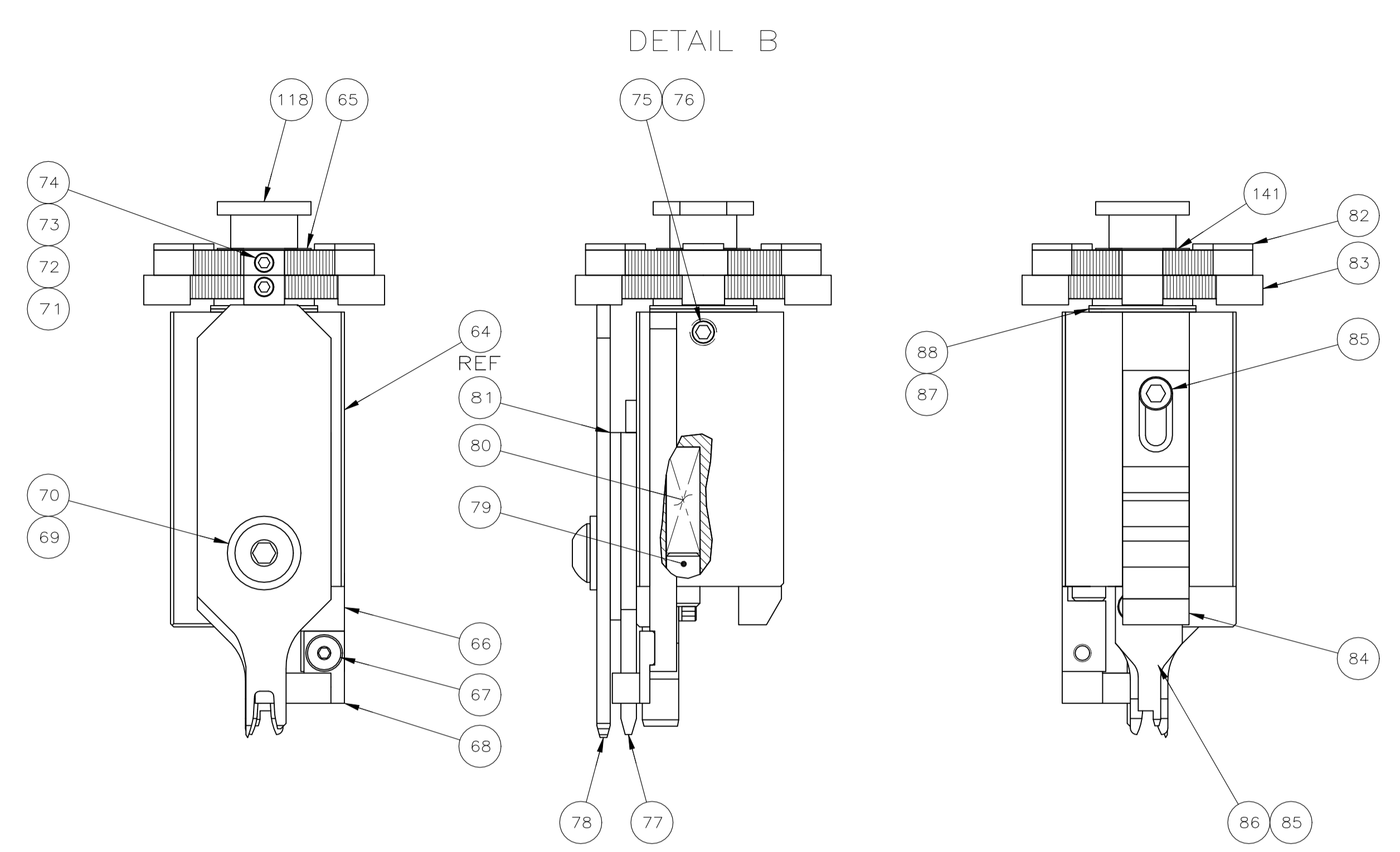
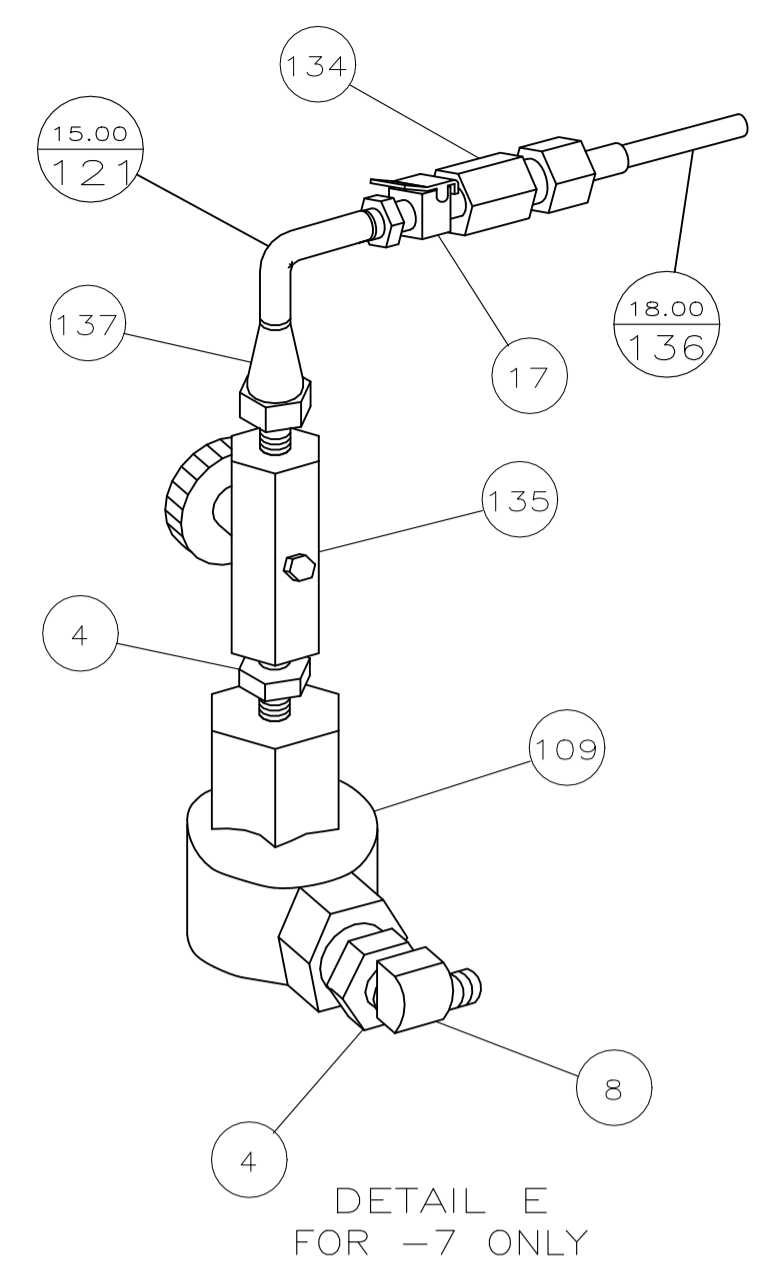
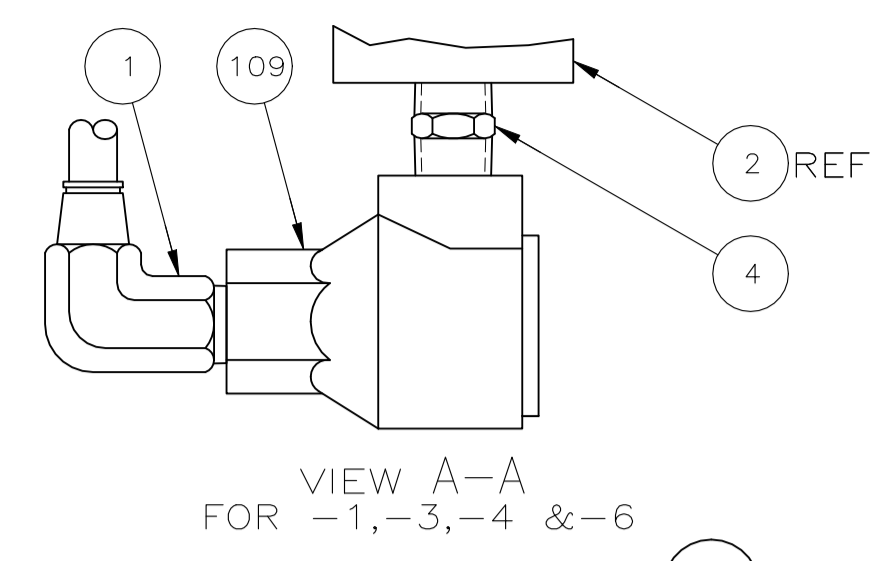

AMP	
APPLICATOR N	852500
TERMINAL N	52097
SERIAL N	
CRIMP HT	WIRE
A .070	#14
B .061	#16
C .055	#18
D N/A	USED

THIS DRAWING IS A CONTROLLED DOCUMENT.		DIN	M. YOUNGER	05OCT2012
DIMENSIONS: INCHES		CHK	T. ELBIN	05OCT2012
TOLERANCES UNLESS OTHERWISE SPECIFIED:		APVD	T. ELBIN	05OCT2012
0. PLC ± .010		NAME	ULTRA POD FLAG APPLICATOR	
1. PLC ± .005		PRODUCT SPEC	-	
2. PLC ± .003		APPLICATION SPEC	-	
3. PLC ± .002		SIZE	CAGE CODE	DRAWING NO
4. PLC ± .001		WEIGHT	A1 00779	C=1852892
ANGLES ± .5		CUSTOMER ACCESSIBLE	PRODUCTION DRAWING	SCALE 1:1 SHEET 3 OF 3 REV B
MATERIAL		RESTRICTED TO		
FINISH		-		

DIMENSIONING AND TOLERANCING PER ASME Y14.5M (USD STANDARDS)