

PART NUMBER	REVISION	DESCRIPTION	FEED TYPE
2150529-1	D	FINE CRIMP HEIGHT ADJUST	MECHANICAL
2150529-2	D	FINE CRIMP HEIGHT ADJUST	PNEUMATIC
7-2150529-7	A	CRIMP TOOLING KIT	-

ATLANTIC VERSION TERMINATOR
 INTERFACE ADAPTER

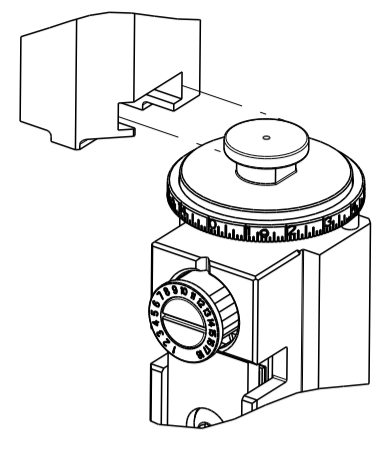

APPLICATOR DATA		
CRIMP	SIZE	TYPE
WIRE	2.30 mm [.091]	F
INSUL	3.30 mm [.130]	F
APPL INSTRUCTIONS 408-35043		

TERMINAL DATA: TE TERMINAL		TE CRIMP SPECIFICATION	
TERMINAL NAME: TERMINAL, PRONER COMATEL 6.35mm CLIP			
WIRE STRIP LENGTH		INSULATION DIAMETER RANGE	
4.60-5.40 mm [.181-.213 IN]		Ø1.30-2.20 mm [.051-.087 IN]	
TERMINAL APPLICATION SPECIFICATION	1544132 - Proner		
TERMINALS APPLIED			
TE TERMINAL	TE TERMINAL	TE TERMINAL	TE TERMINAL
1544132-1	1544132-2	1544132-3	

WIRE SIZE	CRIMP HEIGHT mm [INCH]	CRIMP HEIGHT REFERENCE SETTING
1.00mm2	1.57+/-0.05 [.062+/-0.002]	6.7
0.75mm2	1.55+/-0.05 [.061+/-0.002]	6.8
0.60mm2	1.50+/-0.05 [.059+/-0.002]	7.3
0.50mm2	1.45+/-0.05 [.057+/-0.002]	8.1
0.35mm2	1.40+/-0.05 [.055+/-0.002]	8.6

- 1 RECOMMENDED SPARE PARTS
- 2 REFER TO SUPPLIED INSTRUCTION SHEET FOR CLEANING, LUBRICATION AND STORAGE OF APPLICATOR.
- 3 APPLY PART NUMBER 1-23419-5 LOCTITE TO THREADS OF ITEM 180. APPLY PART NUMBER 2-23419-6 LOCTITE TO THREADS OF ITEM 242.
- 4 CRIMP HEIGHT REFERENCE SETTING WAS THE SETTING USED WHEN THE APPLICATOR WAS QUALIFIED AT THE FACTORY. ADJUSTMENT MAY BE NECESSARY WHEN RUNNING APPLICATOR IN THE FIELD.
- 5 SEE PRONER COMATEL DRG. 0956 C 002 (CUST DRG. 1544132) FOR SPECIFIC WIRE DETAILS.
- 6. UNLESS SPECIFIED OTHERWISE TORQUE VALUES SHALL BE USED PER DOCUMENT, 101-35000.

***WARNING**
 ON INSTALLATION, SET WIRE DISC TO CRIMP HEIGHT REFERENCE SETTING FOR LARGEST WIRE SIZE. CRIMP HEIGHT REFERENCE SETTINGS GREATER THAN THE VALUE SHOWN MAY CAUSE DAMAGE TO THE CRIMP TOOLING, REFER TO THE INSTRUCTION SHEET FOR PROPER SETUP AND ADJUSTMENTS.

LOC	DIST	REVISIONS					
A	66	P	LTN	DESCRIPTION	DATE	DWN	APVD
		A		RELEASED	22APR2015	GH	TE
		B		ECR-18-017668	09NOV2018	FZ	KZ
		C		ECR-18-018887	03DEC2018	MZ	CT
		D		ECR-24-219510	03SEP2024	LG	RK

-	1	-	2119641-1	FEED CAM, AIR FEED	248		
-	1	1	2119082-8	CAM, SNAIL, INSULATION ADJUSTMENT	244		
-	1	1	2079764-1	WASHER, WAVE SPRING, CREST-TO-CREST	243		
3	-	1	1	2119083-1	RETAINER, INSULATION DIAL	242	
-	-	1	2119580-1	MECHANICAL FEED ASSEMBLY	239		
-	1	-	2844940-3	AIR FEED MODULE	238		
-	1	1	1-18028-0	WASHER, FLAT, REG M8	192		
3	-	1	1	1-1752354-2	STANDOFF, HOLD-DOWN	180	
-	1	1	6-993111-6	PIN, SLOTTED SPRING 3.0 X 14.0	177		
-	1	1	8-22280-7	SPRING, COMPRESSION	176		
-	1	1	1752353-2	GUIDE PIN, HOLDDOWN	175		
-	1	1	1901680-2	GUIDE PIN, HOLDDOWN	174		
-	REF REF		994970-2	COUNTER, MAGNETIC	164		
-	1	1	455888-4	SPACER, CRIMPER -	82		
-	1	1	1803607-4	DOCUMENTATION PACKAGE	71		
-	2	2	2-18032-2	SCR, SET, FLT PNT, M3 X 10.0	70		
-	1	1	2119740-1	TAG, IDENTIFICATION	67		
-	2	2	2168078-1	SCREW, DRIVE, RH, RoHS, 2 x .188	66		
-	1	1	1901681-1	HOLDDOWN, TERMINAL	65		
-	2	2	2168400-5	SHCS, LOW HEAD, RoHS, M4 X 20	64		
-	1	1	2168083-2	SCR, SKT HD CAP, RoHS, M4 X 8.0	60		
-	1	1	5-18022-5	SCR, HEX HD CAP, M4 X 6.0	59		
-	-	1	2063961-1	FEED FINGER	58		
-	3	3	2168400-4	SHCS, LOW HEAD, RoHS, M4 X 8	57		
-	2	2	2-2168083-5	SCR, SKT HD CAP, RoHS, M4 X 14	56		
-	2	2	5018030-1	NUT, HEX, REG, RoHS, M3	54		
-	2	2	986965-8	NUT, LOCK, HEX, TORQUE (M4)	53		
-	1	1	1-5018030-0	NUT, HEX, REG, RoHS, M3.5	52		
-	1	-	2063961-1	FEED FINGER	51		
-	1	2	18023-9	SCR, SKT HD CAP M4 X 6.0	49		
-	-	1	2119652-1	FEED CAM, PRE FEED	48		
-	-	1	2119653-1	FEED CAM, POST FEED	47		
-	1	1	2119655-5	APPLICATOR BASIC ASSEMBLY, EF	46		
-	1	1	1803517-1	RAM ASSEMBLY, EF ATLANTIC	44		
-	1	1	1803602-1	SCR, BHSC, RoHS (M8 X 25)	41		
-	7	7	1-18028-2	WASHER, FLAT, REG M4	33		
-	2	2	2168083-9	SCR, SKT HD CAP, RoHS, M4 X 20	31		
-	2	2	2168083-2	SCR, SKT HD CAP, RoHS, M4 X 8.0	29		
-	1	1	240639-1	STRIPPER (MACHINING)	27		
-	2	2	1-2168083-5	SCR, SKT HD CAP, RoHS, M4 X 30	25		
-	1	1	1752371-7	PLATE, STRIP GUIDE	24		
-	1	1	240825-1	PLATE, STRIP HOLD DOWN	23		
-	2	2	2-22281-3	SPRING, COMPRESSION	22		
-	1	1	1803292-4	DRAG	20		
-	2	2	1901259-4	GUIDE, LOWER STRIP	18		
-	4	4	1-2079383-1	SCR, BHSC, RoHS (M6 X 12)	17		
-	1	1	1752360-1	SPACER, HOLD-DOWN	13		
1	-	1	1	240644-1	PLATE, REAR SHEAR	11	
-	-	-	-	-	10		
1	-	1	1	1-690495-2	PLATE, FRONT SHEAR	9	
1	1	1	1	1-1803074-2	ANVIL, COMBINATION, END FEED	8	
1	-	1	1	2217206-4	BLADE, SLUG	7	
-	-	-	-	-	6		
-	1	1	2-240641-7	SPACER	5		
-	1	1	238011-2	BLOCK, CRIMPER SPACER	4		
1	1	1	2-1633961-6	CRIMPER, INSULATION F PREMIUM	3		
-	1	1	455888-5	SPACER, CRIMPER -	2		
1	1	1	1-456406-6	CRIMPER, WIRE PREMIUM	1		
-	77	-	2	1	PART NO	DESCRIPTION	ITEM NO

DIMENSIONS: mm 		TOLERANCES UNLESS OTHERWISE SPECIFIED: 0 PLC ± 1 PLC ± 2 PLC ± 3 PLC ± 4 PLC ± ANGLES ± FINISH		DWN: HOFFNER 23MAR2015 CHK: G. BAILLY 24MAR2015 APVD: G. BAILLY 24MAR2014 PRODUCT SPEC APPLICATION SPEC WEIGHT: - SCALE: A 00779 C=2150529		NAME: Ocean End Feed Applicator SIZE: - CAGE CODE: - DRAWING NO: - RESTRICTED TO: - Customer Accessible Production Drawing SCALE: 1:1 SHEET 1 OF 4 REV: D	
-----------------------	--	---	--	--	--	---	--

LOC	DIST	REV	DESCRIPTION	DATE	OWN	APVD
A	66		SEE SHEET 1			

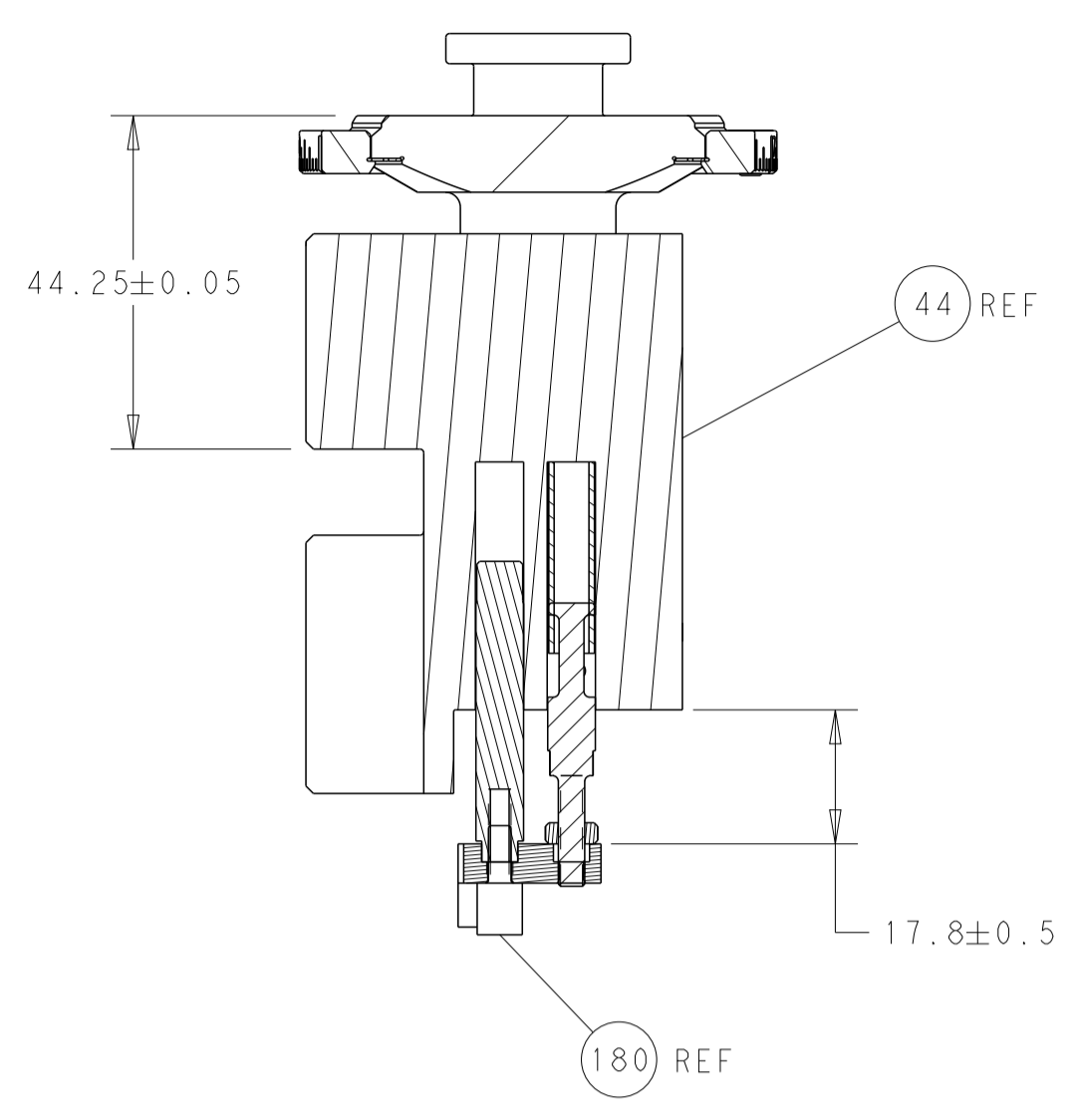

RAM AND HOLDDOWN SET-UP

FEED TYPE MECHANICAL

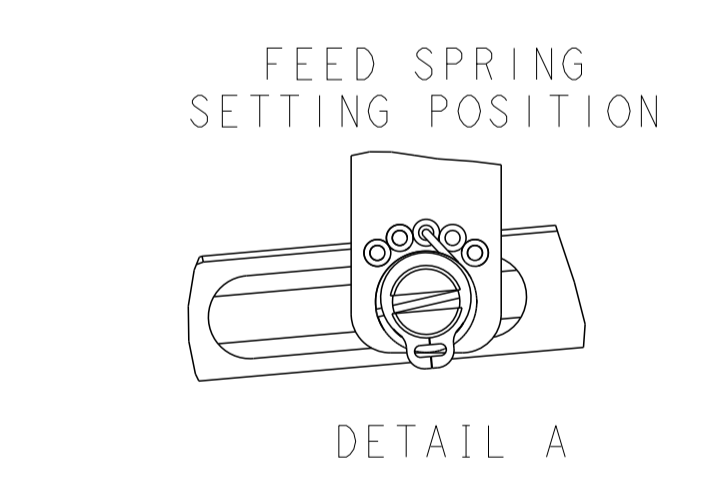
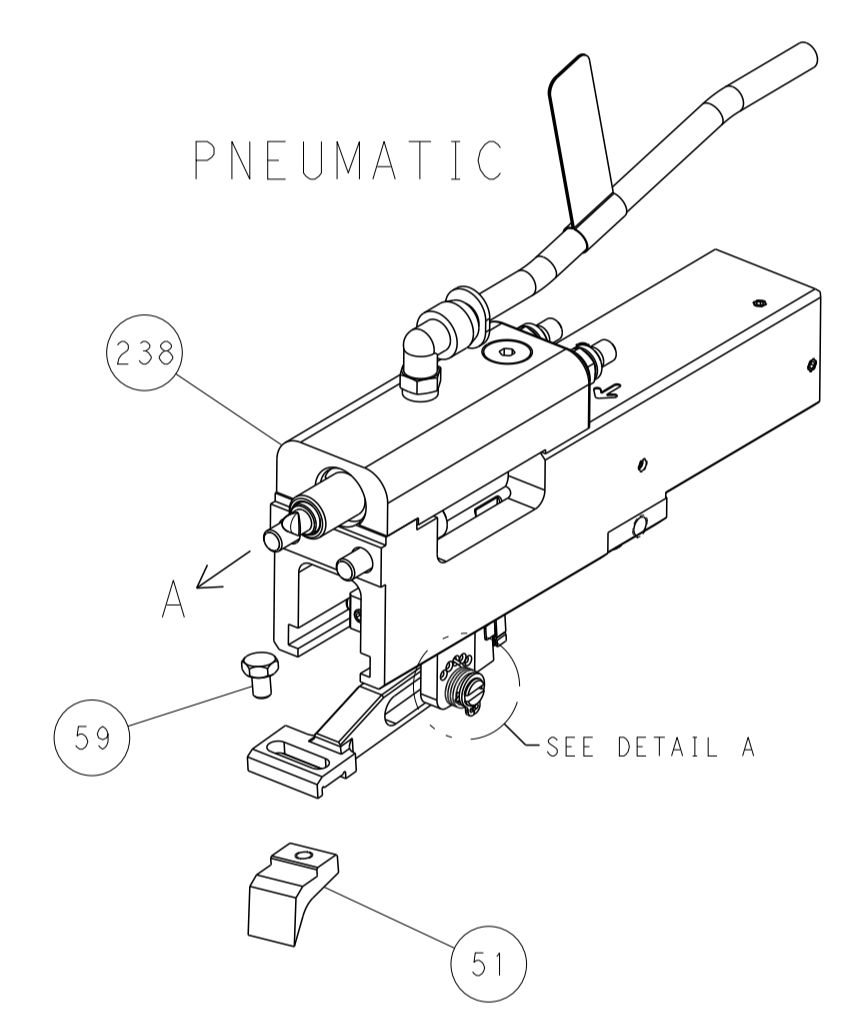
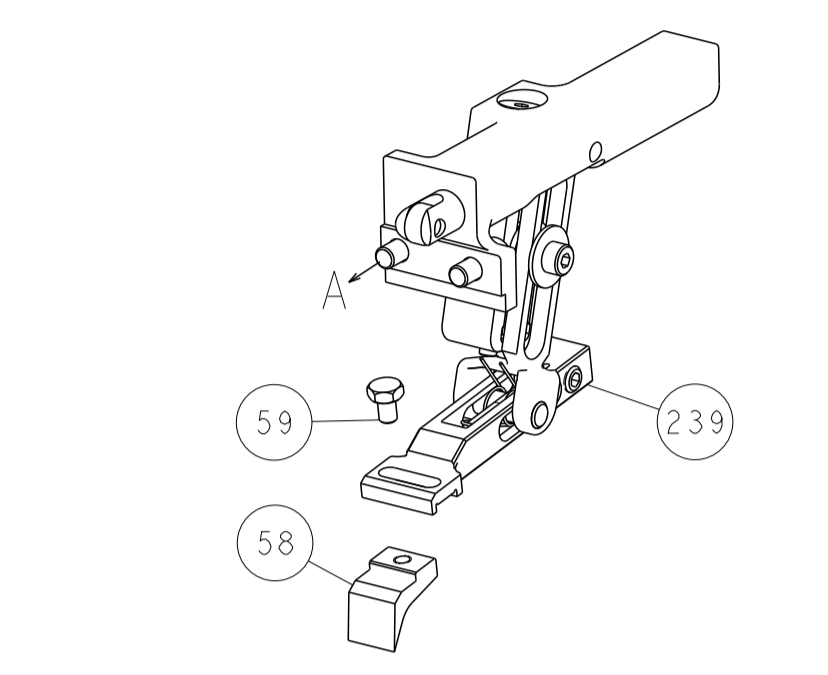
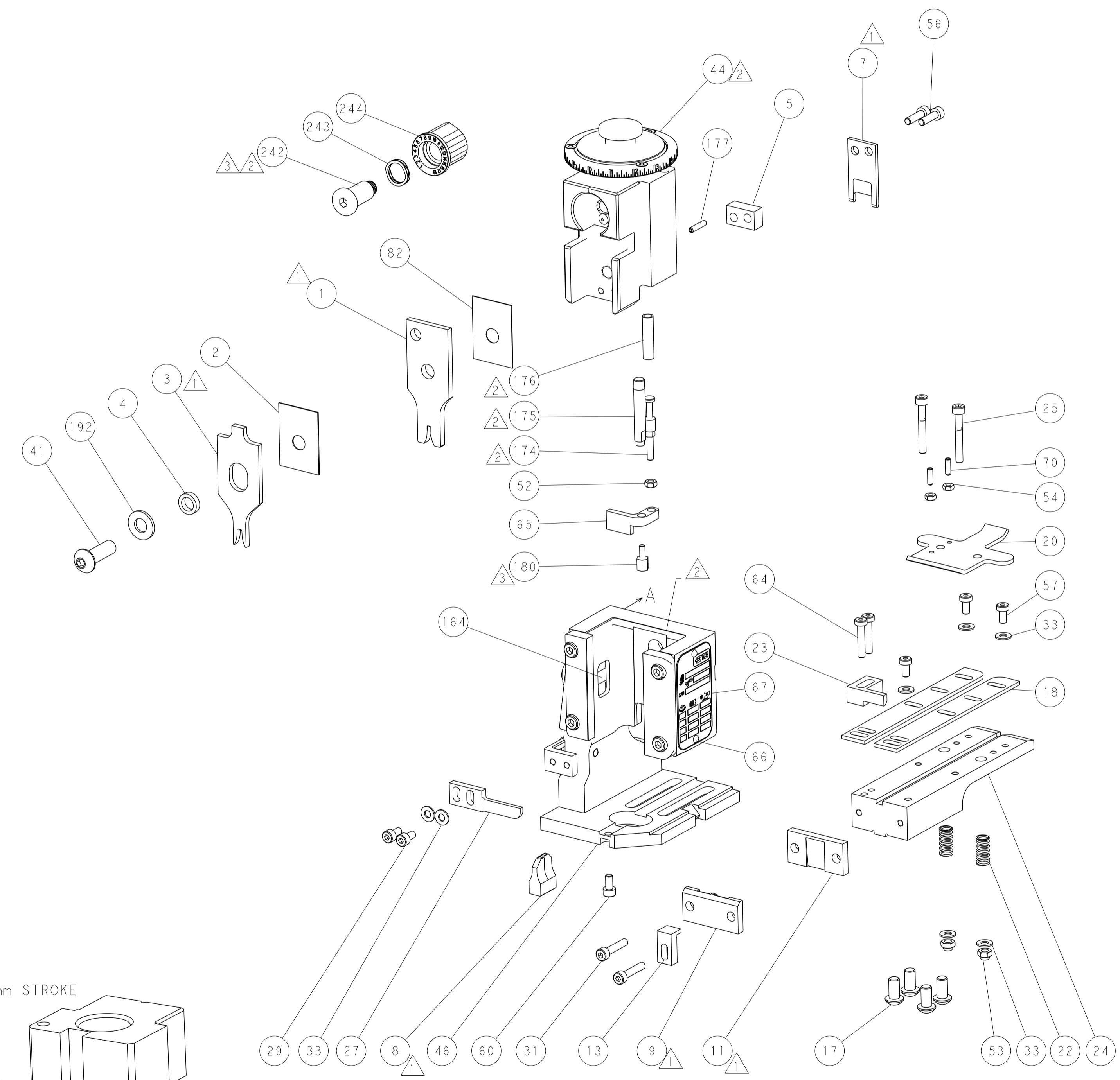

CAM POSITIONS

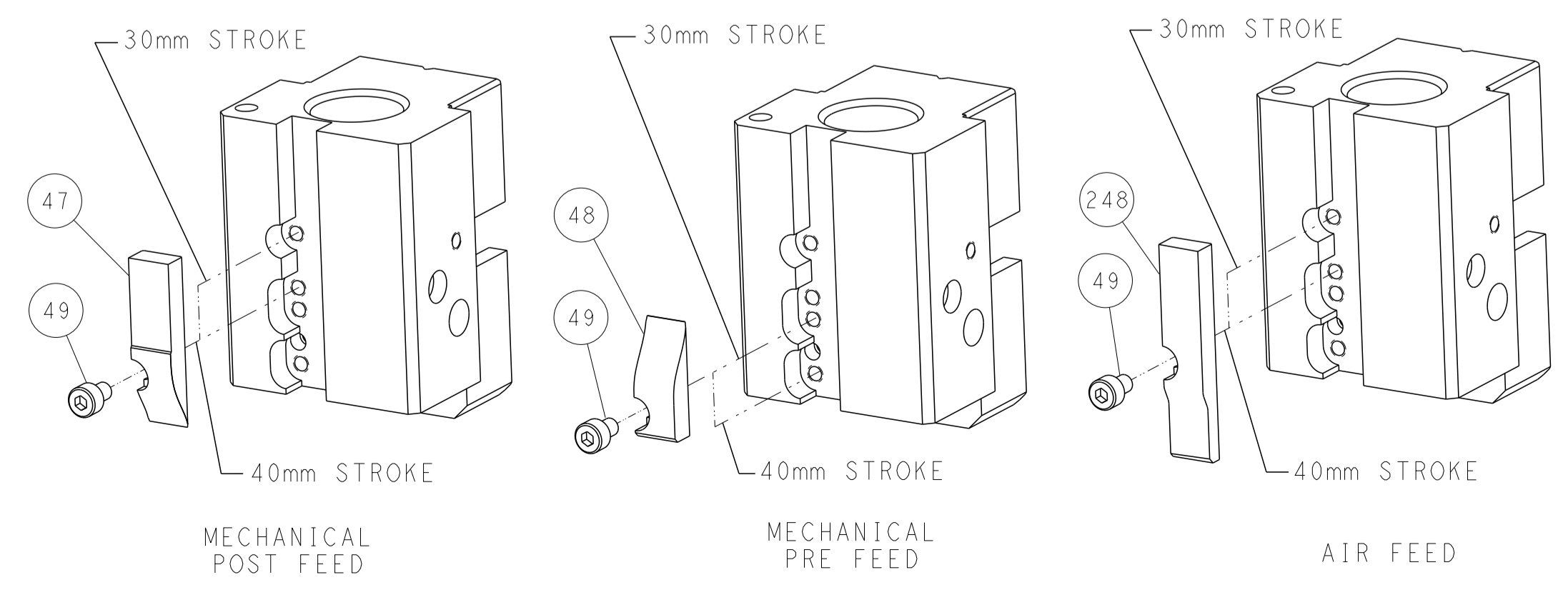

DIMENSIONS: mm 		TOLERANCES UNLESS OTHERWISE SPECIFIED: 0 PLC ± 1 PLC ± 2 PLC ± 3 PLC ± 4 PLC ± ANGLES ± FINISH		DWN: HOFFNER 23MAR2015 CHK: G. BAILEY 24MAR2015 APVD: G. BAILEY 24MAR2014 NAME: Ocean End Feed Applicator SIZE: A1 CAGE CODE: 00779 DRAWING NO: 2150529 SCALE: 1:1 SHEET: 2 of 4 REV: D		RESTRICTED TO:	
MATERIAL: -		WEIGHT: -		CUSTOMER ACCESSIBLE PRODUCTION DRAWING		SHEETS 3 & 4 ARE NOT REQUIRED FOR ATLANTIC VERSION	