

PART NUMBER	REVISION	DESCRIPTION	FEED TYPE
2150624-1	F	FINE CRIMP HEIGHT ADJUST	MECHANICAL
2150624-2	F	FINE CRIMP HEIGHT ADJUST	PNEUMATIC
7-2150624-7	A	CRIMP TOOLING KIT	-

ATLANTIC VERSION TERMINATOR  
 INTERFACE ADAPTER

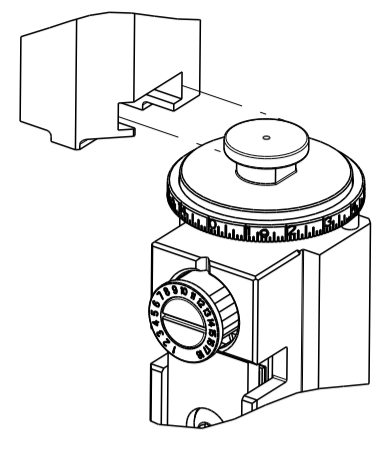

APPLICATOR DATA		
CRIMP	SIZE	TYPE
WIRE	4.83 mm [.190]	F
APPL INSTRUCTIONS 408-35043		

TERMINAL DATA: TE TERMINAL TE CRIMP SPECIFICATION			
TERMINAL NAME: RING TERMINAL			
WIRE STRIP LENGTH		INSULATION DIAMETER RANGE	
5.95-6.75 mm [.234-.266 IN]		Ø	
TERMINAL APPLICATION SPECIFICATION	114-2084	-	-
TERMINALS APPLIED <sup>4</sup>			
TE TERMINAL	TE TERMINAL	TE TERMINAL	TE TERMINAL
40696			

WIRE SIZE	CRIMP HEIGHT mm [INCH]	CRIMP HEIGHT REFERENCE SETTING
10 AWG	3.18 +/- 0.05 [.125 +/- .002]	6.5
12 AWG	2.82 +/- 0.05 [.111 +/- .002]	11.0

- <sup>1</sup> RECOMMENDED SPARE PARTS
- <sup>2</sup> REFER TO SUPPLIED INSTRUCTION SHEET FOR CLEANING, LUBRICATION AND STORAGE OF APPLICATOR.
- <sup>3</sup> CRIMP HEIGHT REFERENCE SETTING WAS THE SETTING USED WHEN THE APPLICATOR WAS QUALIFIED AT THE FACTORY. ADJUSTMENT MAY BE NECESSARY WHEN RUNNING APPLICATOR IN THE FIELD.
- <sup>4</sup> TERMINAL LUBRICANT IS RECOMMENDED.
- 5. UNLESS SPECIFIED OTHERWISE TORQUE VALUES SHALL BE USED PER DOCUMENT, 101-35000.

**\*WARNING**  
 ON INSTALLATION, SET WIRE DISC TO CRIMP HEIGHT REFERENCE SETTING FOR LARGEST WIRE SIZE. CRIMP HEIGHT REFERENCE SETTINGS GREATER THAN THE VALUE SHOWN MAY CAUSE DAMAGE TO THE CRIMP TOOLING, REFER TO THE INSTRUCTION SHEET FOR PROPER SETUP AND ADJUSTMENTS.

LOC	DIST	REVISIONS					
A	66	P	LTN	DESCRIPTION	DATE	DWN	APVD
		D		ECR-18-016742	24OCT2018	FZ	KZ
		E		ECR-19-009780	24JUN2019	FZ	TB
		F		ECR-24-198624	26JAN2024	TB	RK
		F1		ECR-24-222406	03OCT2024	AB	RK

-	1	1	1803203-1	BLOCK, FRONT DEPRESSOR	261	
-	1	-	2119641-1	FEED CAM, AIR FEED	248	
-	-	1	2119580-1	MECHANICAL FEED ASSEMBLY	239	
-	1	-	2844940-3	AIR FEED MODULE	238	
-	REFREF		994970-2	COUNTER, MAGNETIC	164	
<sup>4</sup>	-	1	2119955-2	ASSY, LUBRICATOR, END FEED	84	
-	1	1	455888-5	SPACER, CRIMPER	82	
-	1	1	2119791-6	DEPRESSOR, WIRE	73	
-	1	1	1803607-4	DOCUMENTATION PACKAGE	71	
-	2	2	2-18032-2	SCR, SET, FLT PNT, M3 X 10.0	70	
-	1	1	2119943-1	WASHER, SPACER	69	
-	1	1	2119740-1	TAG, IDENTIFICATION	67	
-	2	2	2168078-1	SCREW, DRIVE, RH, RoHS, 2 x .188	66	
-	1	1	2168083-2	SCR, SKT HD CAP, RoHS, M4 X 8.0	60	
-	1	1	5-18022-5	SCR, HEX HD CAP, M4 X 6.0	59	
-	-	1	2063961-1	FEED FINGER	58	
-	4	4	2168400-4	SHCS, LOW HEAD, RoHS, M4 X 8	57	
-	2	2	2168083-3	SCR, SKT HD CAP, RoHS, M4 X 12.0	56	
-	2	2	5018030-1	NUT, HEX, REG, RoHS, M3	54	
-	2	2	986965-8	NUT, LOCK, HEX, TORQUE (M4)	53	
-	1	-	2063961-1	FEED FINGER	51	
-	1	2	18023-9	SCR, SKT HD CAP M4 X 6.0	49	
-	-	1	2119652-1	FEED CAM, PRE FEED	48	
-	-	1	2119653-1	FEED CAM, POST FEED	47	
-	1	1	2119655-5	APPLICATOR BASIC ASSEMBLY, EF	46	
-	1	1	1803517-1	RAM ASSEMBLY, EF ATLANTIC	44	
-	1	1	1803602-1	SCR, BHSC, RoHS (M8 X 25)	41	
-	8	8	1-18028-2	WASHER, FLAT, REG M4	33	
-	2	2	2168083-9	SCR, SKT HD CAP, RoHS, M4 X 20	31	
-	2	2	2168083-2	SCR, SKT HD CAP, RoHS, M4 X 8.0	29	
-	1	1	240639-1	STRIPPER (MACHINING)	27	
-	2	2	1-2168083-5	SCR, SKT HD CAP, RoHS, M4 X 30	25	
-	1	1	1752371-5	PLATE, STRIP GUIDE	24	
-	2	2	2-22281-3	SPRING, COMPRESSION	22	
-	1	1	1803292-4	DRAG	20	
-	1	1	1901696-1	STRIP GUIDE, REAR	19	
-	1	1	1901695-1	STRIP GUIDE, FRONT	18	
-	4	4	1-2079383-1	SCR, BHSC, RoHS (M6 X 12)	17	
<sup>1</sup>	-	1	240644-1	PLATE, REAR SHEAR	11	
-	-	-	-	-	10	
<sup>1</sup>	-	1	690482-7	PLATE, FRONT SHEAR	9	
<sup>1</sup>	1	1	1-1803002-6	ANVIL, COMBINATION, END FEED	8	
<sup>1</sup>	-	1	1-2217206-6	BLADE, SLUG	7	
-	-	-	-	-	6	
-	1	1	2-240641-5	SPACER	5	
-	-	-	-	-	4	
-	-	-	-	-	3	
-	-	-	-	-	2	
<sup>1</sup>	1	1	1	456429-2	CRIMPER, WIRE	1
-	77	2	-1	PART NO	DESCRIPTION	ITEM NO

DIMENSIONS:		TOLERANCES UNLESS OTHERWISE SPECIFIED:		DWN		TE Connectivity	
mm		0 PLC ±		Y. YIN		Harrisburg, PA 17105-3608	
		1 PLC ±		G. BAILEY		NAME	
		2 PLC ±		U. GUO		Ocean End Feed	
		3 PLC ±		APVD		Applicator	
		4 PLC ±		23SEP2015		-	
		ANGLES		PRODUCT SPEC		SIZE	
		FINISH		APPLICATION SPEC		CAGE CODE	
MATERIAL				WEIGHT		DRAWING NO	
				A1 00779		RESTRICTED TO	
				Customer Accessible Production Drawing		SCALE	
				1:1		SHEET 1 OF 4	
						REV F1	

LOC	DIST	REVISIONS					
A	66	P	LTM	DESCRIPTION	DATE	OWN	APVD
		-	-	SEE SHEET 1	-	-	-

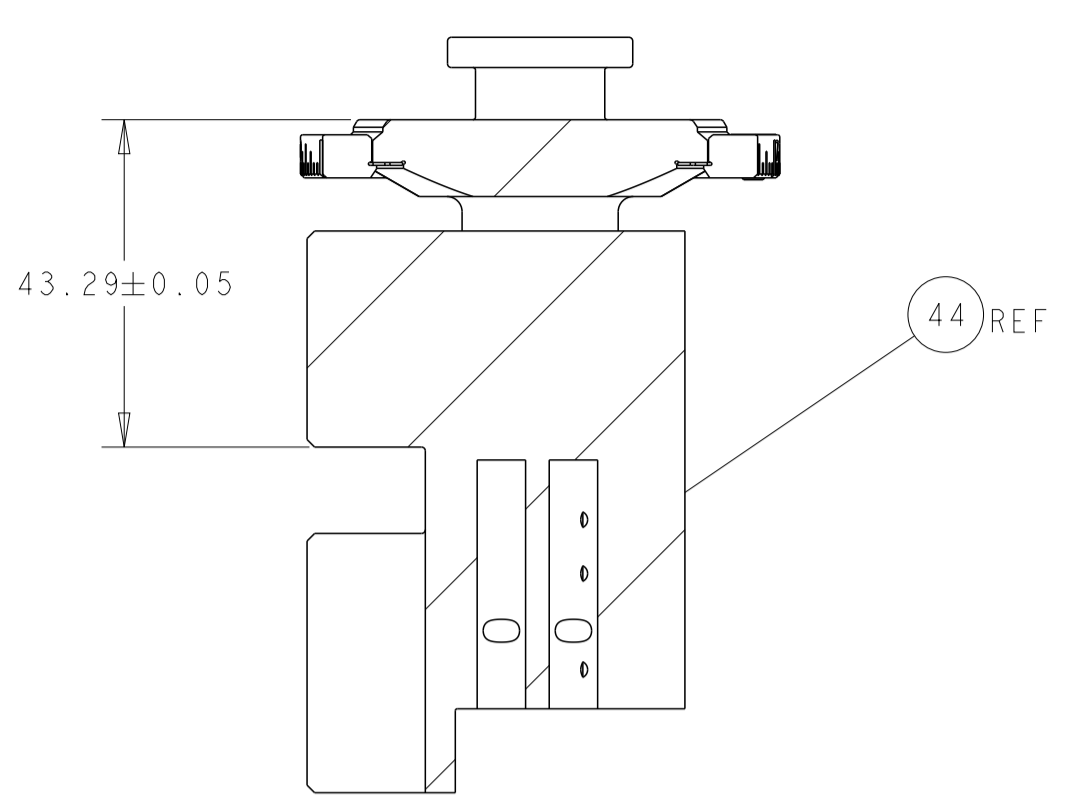

RAM SET-UP

FEED TYPE  
MECHANICAL

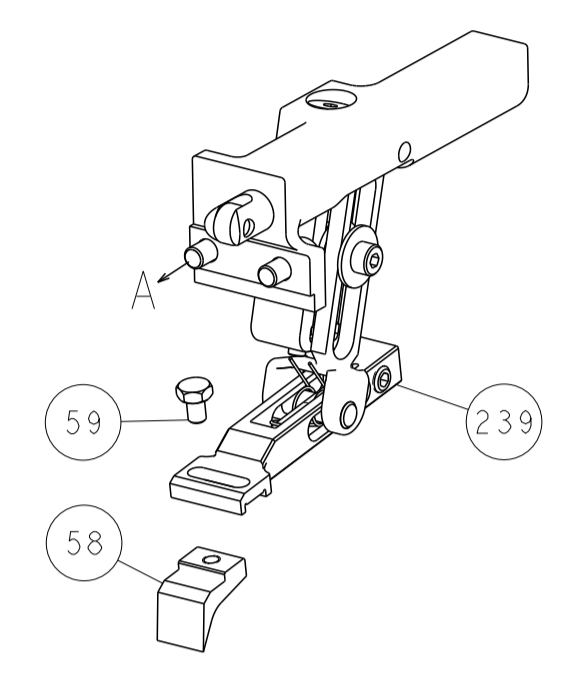

PNEUMATIC

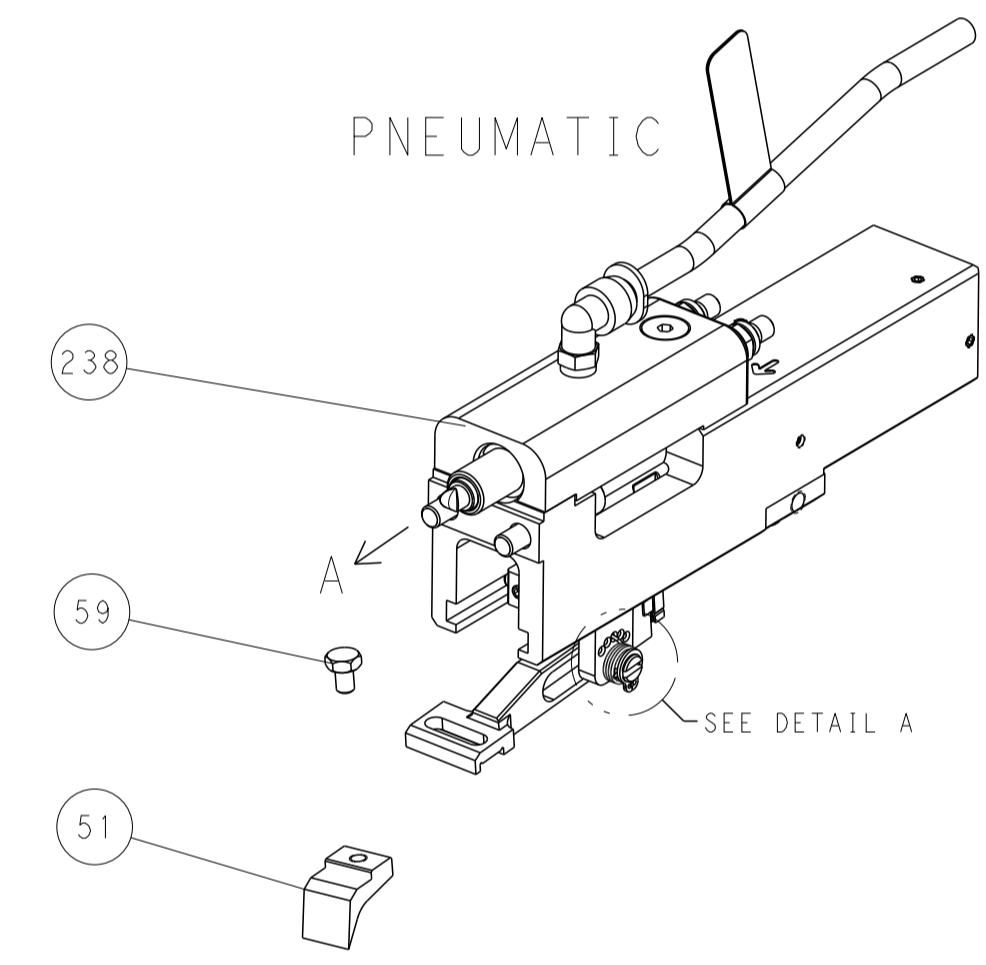

FEED SPRING  
SETTING POSITION

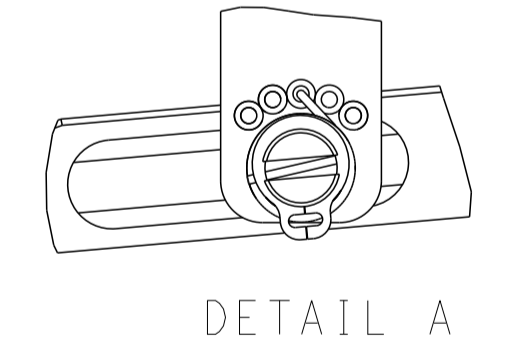

CAM POSITIONS

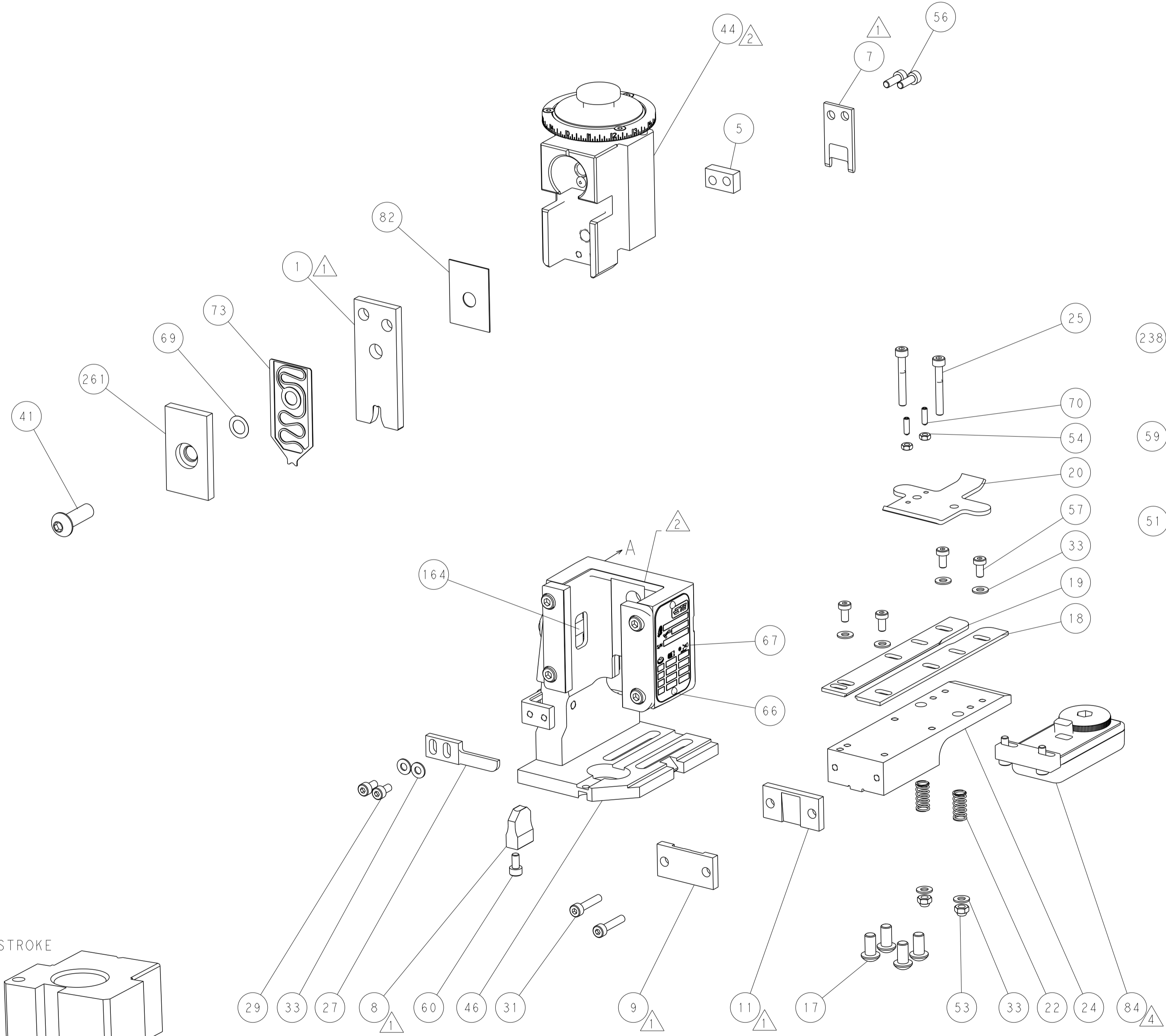
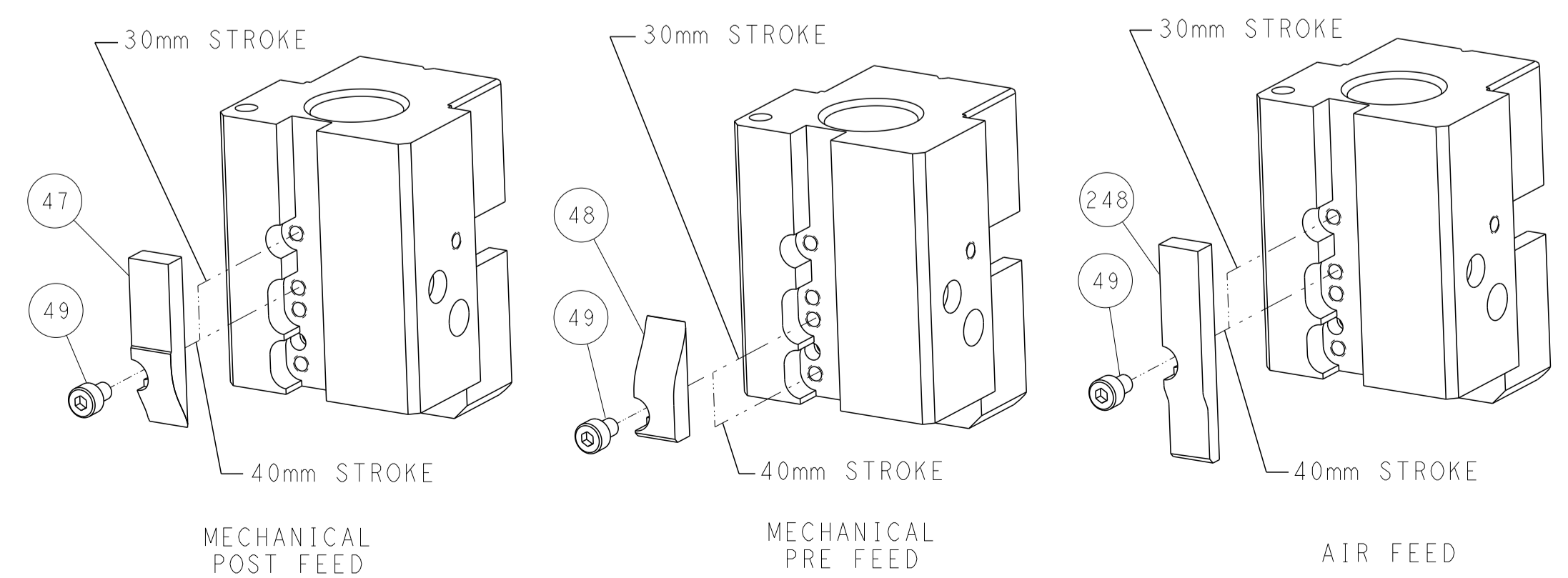

DIMENSIONS: mm 		TOLERANCES UNLESS OTHERWISE SPECIFIED: 0 PLC ± 1 PLC ± 2 PLC ± 3 PLC ± 4 PLC ± ANGLES ± FINISH		DWN Y. YIN 23SEP2015 CHK G. BAILEY 23SEP2015 APVD H. GUO 23SEP2015		TE Connectivity Harrisburg, PA 17105-3608	
MATERIAL:		WEIGHT:		NAME: Ocean End Feed Applicator		SIZE: A1 CAGE CODE: 00779 DRAWING NO: C=2150624	
CUSTOMER ACCESSIBLE PRODUCTION DRAWING		SCALE: 1:1		SHEET: 2 OF 4		REV: F1	