

| PART NUMBER | REVISION | DESCRIPTION | FEED TYPE |
|-------------|----------|----------------------------------|------------|
| 2150787-1 | B | FINE CRIMP HEIGHT ADJUST | MECHANICAL |
| 2150787-2 | B | FINE CRIMP HEIGHT ADJUST | PNEUMATIC |
| 7-2150787-1 | B | MECHANICAL AND CRIMP TOOLING KIT | MECHANICAL |
| 7-2150787-2 | B | PNEUMATIC AND CRIMP TOOLING KIT | PNEUMATIC |
| 7-2150787-7 | A | CRIMP TOOLING KIT | - |

ATLANTIC VERSION TERMINATOR INTERFACE ADAPTER



| APPLICATOR DATA | | |
|--------------------------------|----------------|------|
| CRIMP | SIZE | TYPE |
| WIRE | 2.03 mm [.080] | F |
| INSUL | 3.56 mm [.140] | O |
| APPL INSTRUCTIONS 408-35043 | | |

| TERMINAL DATA: TE TERMINAL | | TE CRIMP SPECIFICATION | |
|--|-------------|------------------------------|-------------|
| TERMINAL NAME: .093 DIA PIN RECEPTACLE | | | |
| WIRE STRIP LENGTH | | INSULATION DIAMETER RANGE | |
| 3.58-4.34 mm [.141-.171 IN] | | ∅2.29-3.05 mm [.090-.120 IN] | |
| TERMINAL APPLICATION SPECIFICATION | 114-2080 | | |
| TERMINALS APPLIED | | | |
| TE TERMINAL | TE TERMINAL | TE TERMINAL | TE TERMINAL |
| 42T01-2 | | | |

| WIRE SIZE | CRIMP HEIGHT mm [INCH] | CRIMP HEIGHT REFERENCE SETTING |
|-----------|----------------------------|--------------------------------|
| 16 AWG | 1.73+/-0.05 [.068+/-0.002] | 7.9 |
| 18 AWG | 1.52+/-0.05 [.060+/-0.002] | 10.1 |

- RECOMMENDED SPARE PARTS
- REFER TO SUPPLIED INSTRUCTION SHEET FOR CLEANING, LUBRICATION AND STORAGE OF APPLICATOR.
- APPLY PART NUMBER 2-23419-6 LOCTITE TO THREADS OF ITEM 242. APPLY PART NUMBER 1-23419-5 LOCTITE TO THREADS OF ITEM 180.
- CRIMP HEIGHT REFERENCE SETTING WAS THE SETTING USED WHEN THE APPLICATOR WAS QUALIFIED AT THE FACTORY. ADJUSTMENT MAY BE NECESSARY WHEN RUNNING APPLICATOR IN THE FIELD.
- TERMINAL LUBRICANT IS RECOMMENDED.
- 6. UNLESS SPECIFIED OTHERWISE TORQUE VALUES SHALL BE USED PER DOCUMENT, 101-35000.

***WARNING**
ON INSTALLATION, SET WIRE DISC TO CRIMP HEIGHT REFERENCE SETTING FOR LARGEST WIRE SIZE. CRIMP HEIGHT REFERENCE SETTINGS GREATER THAN THE VALUE SHOWN MAY CAUSE DAMAGE TO THE CRIMP TOOLING. REFER TO THE INSTRUCTION SHEET FOR PROPER SETUP AND ADJUSTMENTS.

| LOC | DIST | REVISIONS | | | | | |
|-----|------|-----------|-----|---------------|-----------|-----|------|
| A | 66 | P | LTN | DESCRIPTION | DATE | OWN | APVD |
| | | A | | RELEASE | 14APR2017 | MZ | TE |
| | | B | | ECR-19-005424 | 03APR2019 | TB | CT |

| | | | | | | | | | |
|---|-----|-----|-----|-----|-------------|-------------------------------------|-------------------------------|-------------|---------|
| - | 1 | - | 1 | - | 2119640-1 | PUSH ROD, AIR FEED | 250 | | |
| - | 1 | - | 1 | - | 1803259-1 | BUSHING, FLANGED | 249 | | |
| - | 1 | - | 1 | - | 2119641-1 | FEED CAM, AIR FEED | 248 | | |
| - | 1 | 1 | 1 | 1 | 2119082-3 | CAM, SNAIL, INSULATION ADJUSTMENT | 244 | | |
| - | 1 | 1 | 1 | 1 | 2079764-1 | WASHER, WAVE SPRING, CREST-TO-CREST | 243 | | |
| | - | 1 | 1 | 1 | 2119083-1 | RETAINER, INSULATION DIAL | 242 | | |
| - | - | 1 | - | 1 | 2119580-1 | MECHANICAL FEED ASSEMBLY | 239 | | |
| - | 1 | - | 1 | - | 2063440-1 | AIR FEED MODULE | 238 | | |
| - | 1 | 1 | 1 | 1 | 1-18028-0 | WASHER, FLAT, REG M8 | 192 | | |
| | - | 1 | 1 | 1 | 1752354-9 | STANDOFF, HOLD-DOWN | 180 | | |
| - | 1 | 1 | 1 | 1 | 6-993111-6 | PIN, SLOTTED SPRING 3.0 X 14.0 | 177 | | |
| - | 1 | 1 | 1 | 1 | 8-22280-7 | SPRING, COMPRESSION | 176 | | |
| - | 1 | 1 | 1 | 1 | 1752353-2 | GUIDE PIN, HOLDDOWN | 175 | | |
| - | 1 | 1 | 1 | 1 | 1901680-2 | GUIDE PIN, HOLDDOWN | 174 | | |
| - | 2 | - | 2 | - | 21045-3 | RING, RETAIN, EXTERN, 3/16 CRESCENT | 172 | | |
| - | REF | REF | REF | REF | 994970-2 | COUNTER, MAGNETIC | 164 | | |
| - | 1 | - | 1 | - | 240638-1 | SPRING, FEED FINGER | 163 | | |
| - | 1 | - | 1 | - | 3-23627-7 | PIN, RETAIN, GRVD, 3/16 X .854 | 137 | | |
| | - | 1 | 1 | 1 | 2119955-2 | ASSY, LUBRICATOR, END FEED | 84 | | |
| - | 1 | 1 | 1 | 1 | 455888-6 | SPACER, CRIMPER | 82 | | |
| - | 1 | 1 | 1 | 1 | 1803607-2 | DOCUMENTATION PACKAGE | 71 | | |
| - | 2 | 2 | 2 | 2 | 2-18032-2 | SCR, SET, FLT PNT, M3 X 10.0 | 70 | | |
| - | 1 | 1 | 1 | 1 | 2119740-1 | TAG, IDENTIFICATION | 67 | | |
| - | 2 | 2 | 2 | 2 | 2168078-1 | SCREW, DRIVE, RH, RoHS, 2 x .188 | 66 | | |
| - | 1 | 1 | 1 | 1 | 1-1901681-3 | HOLDDOWN, TERMINAL | 65 | | |
| - | 2 | 2 | 2 | 2 | 2168400-8 | SHCS, LOW HEAD, RoHS, M4 X 16 | 64 | | |
| - | 1 | 1 | 1 | 1 | 2168083-2 | SCR, SKT HD CAP, RoHS, M4 X 8.0 | 60 | | |
| - | - | 1 | - | 1 | 5-18022-5 | SCR, HEX HD CAP, M4 X 6.0 | 59 | | |
| - | - | 1 | - | 1 | 2063961-1 | FEED FINGER | 58 | | |
| - | 3 | 3 | 3 | 3 | 2168400-4 | SHCS, LOW HEAD, RoHS, M4 X 8 | 57 | | |
| - | 2 | 2 | 2 | 2 | 2168083-2 | SCR, SKT HD CAP, RoHS, M4 X 8.0 | 56 | | |
| - | 2 | 2 | 2 | 2 | 5018030-1 | NUT, HEX, REG, RoHS, M3 | 54 | | |
| - | 2 | 2 | 2 | 2 | 986965-8 | NUT, LOCK, HEX, TORQUE (M4) | 53 | | |
| - | 1 | 1 | 1 | 1 | 1-5018030-0 | NUT, HEX, REG, RoHS, M3.5 | 52 | | |
| - | 1 | - | 1 | - | 2119792-1 | PAWL, EF, AIR | 51 | | |
| - | 1 | 2 | 1 | 2 | 18023-9 | SCR, SKT HD CAP M4 X 6.0 | 49 | | |
| - | - | 1 | - | 1 | 2119652-1 | FEED CAM, PRE FEED | 48 | | |
| - | - | 1 | - | 1 | 2119653-1 | FEED CAM, POST FEED | 47 | | |
| - | 1 | 1 | 1 | 1 | 2119655-5 | APPLICATOR BASIC ASSEMBLY, EF | 46 | | |
| - | 1 | 1 | 1 | 1 | 1803517-1 | RAM ASSEMBLY, EF ATLANTIC | 44 | | |
| - | 1 | 1 | 1 | 1 | 1803602-1 | SCR, BHSC, RoHS (M8 X 25) | 41 | | |
| - | 7 | 7 | 7 | 7 | 1-18028-2 | WASHER, FLAT, REG M4 | 33 | | |
| - | 2 | 2 | 2 | 2 | 2168083-8 | SCR, SKT HD CAP, RoHS, M4 X 16 | 31 | | |
| - | 2 | 2 | 2 | 2 | 2168083-2 | SCR, SKT HD CAP, RoHS, M4 X 8.0 | 29 | | |
| - | 1 | 1 | 1 | 1 | 240639-4 | STRIPPER (MACHINING) | 27 | | |
| - | 2 | 2 | 2 | 2 | 1-2168083-5 | SCR, SKT HD CAP, RoHS, M4 X 30 | 25 | | |
| - | 1 | 1 | 1 | 1 | 1752371-5 | PLATE, STRIP GUIDE | 24 | | |
| - | 1 | 1 | 1 | 1 | 240825-4 | PLATE, STRIP HOLD DOWN | 23 | | |
| - | 2 | 2 | 2 | 2 | 2-22281-3 | SPRING, COMPRESSION | 22 | | |
| - | 1 | 1 | 1 | 1 | 1803292-4 | DRAG | 20 | | |
| - | 2 | 2 | 2 | 2 | 1901259-4 | GUIDE, LOWER STRIP | 18 | | |
| - | 4 | 4 | 4 | 4 | 1-2079383-1 | SCR, BHSC, RoHS (M6 X 12) | 17 | | |
| - | 1 | 1 | 1 | 1 | 1752360-1 | SPACER, HOLD-DOWN | 13 | | |
| | - | 1 | 1 | 1 | 240644-9 | PLATE, REAR SHEAR | 11 | | |
| - | - | - | - | - | - | - | 10 | | |
| | - | 1 | 1 | 1 | 5-690482-7 | PLATE, FRONT SHEAR | 9 | | |
| | 1 | 2 | 2 | 1 | 1 | 2-1803257-6 | ANVIL, COMBINATION, END FEED | 8 | |
| | - | 1 | 1 | 1 | 1 | 2217206-4 | BLADE, SLUG | 7 | |
| - | - | - | - | - | - | - | 6 | | |
| - | 1 | 1 | 1 | 1 | 1 | 1-240641-1 | SPACER | 5 | |
| - | 1 | 1 | 1 | 1 | 1 | 238011-2 | BLOCK, CRIMPER SPACER | 4 | |
| | 1 | 2 | 2 | 1 | 1 | 3-1803248-4 | CRIMPER, INSULATION O PREMIUM | 3 | |
| - | 1 | 1 | 1 | 1 | 1 | 455888-1 | SPACER, CRIMPER | 2 | |
| | 1 | 2 | 2 | 1 | 1 | 5-456405-2 | CRIMPER, WIRE PREMIUM | 1 | |
| - | 77 | 72 | 71 | 2 | - | 1 | PART NO | DESCRIPTION | ITEM NO |

ATLANTIC VERSION
Shown on sheets 1 of 4 & 2 of 4
(Pacific version shown on sheets 3 of 4 & 4 of 4)

| DIMENSIONS: | | TOLERANCES UNLESS OTHERWISE SPECIFIED: | | APPROVED: | | NAME: | |
|--|---------|--|---------|-----------|---------|--------------|--------|
| mm | 0 PLC ± | 1 PLC ± | 2 PLC ± | 3 PLC ± | 4 PLC ± | ANGLES ± | FINISH |
| MATERIAL | | FINISH | | WEIGHT | | SCALE | |
| - | | - | | - | | 1:1 | |
| Customer Accessible Production Drawing | | | | SCALE | | SHEET 1 OF 4 | |
| AMP 4805 REV 31MAR2000 | | | | 00779 | | REV B | |

| LOC | | DIST | | REVISIONS | | | |
|-----|----|------|-----|-------------|------|-----|------|
| A | 66 | P | LTM | DESCRIPTION | DATE | OWN | APVD |
| | | - | | SEE SHEET 1 | | | |

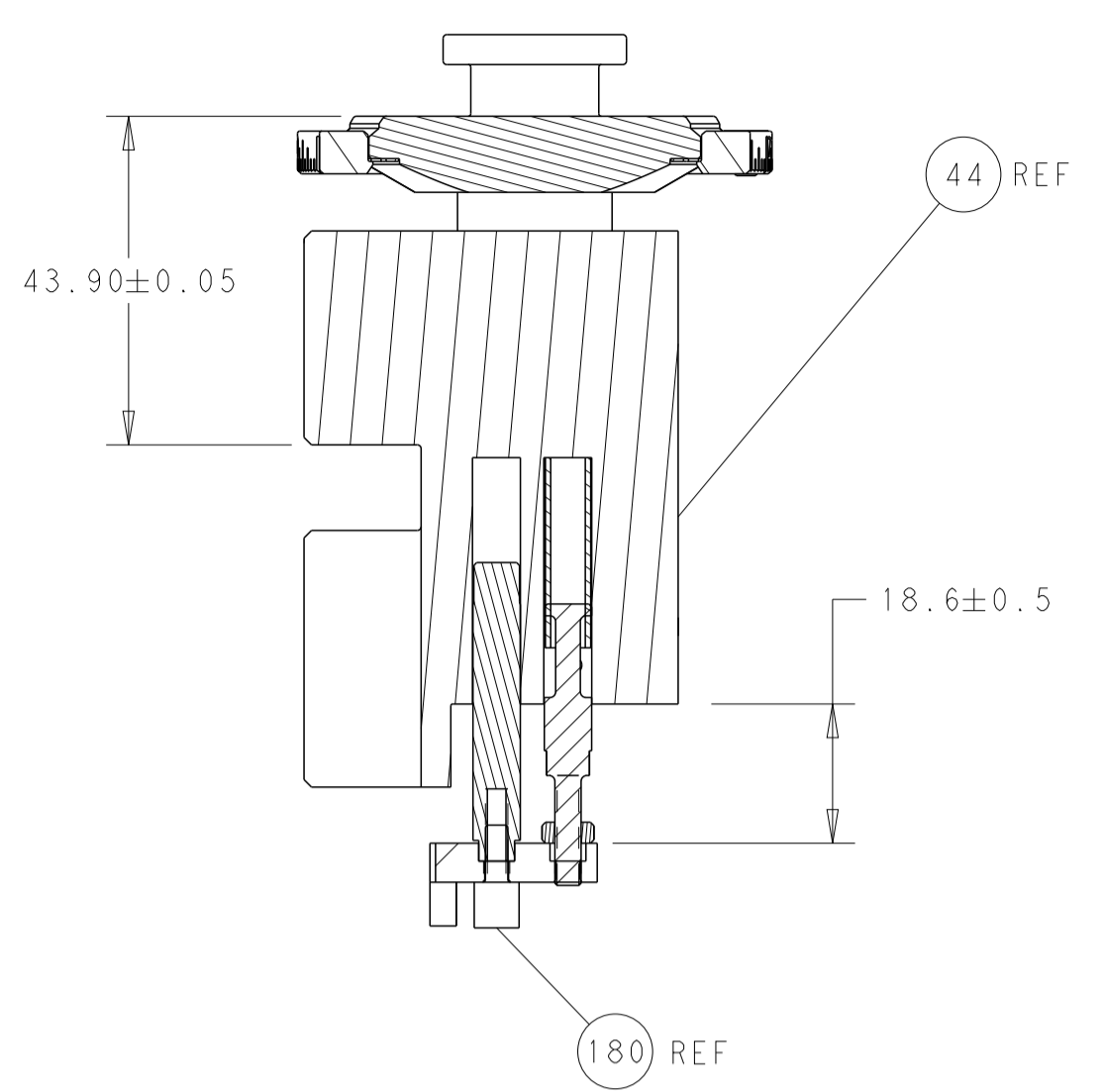

RAM AND HOLDDOWN SET-UP

FEED TYPE
MECHANICAL

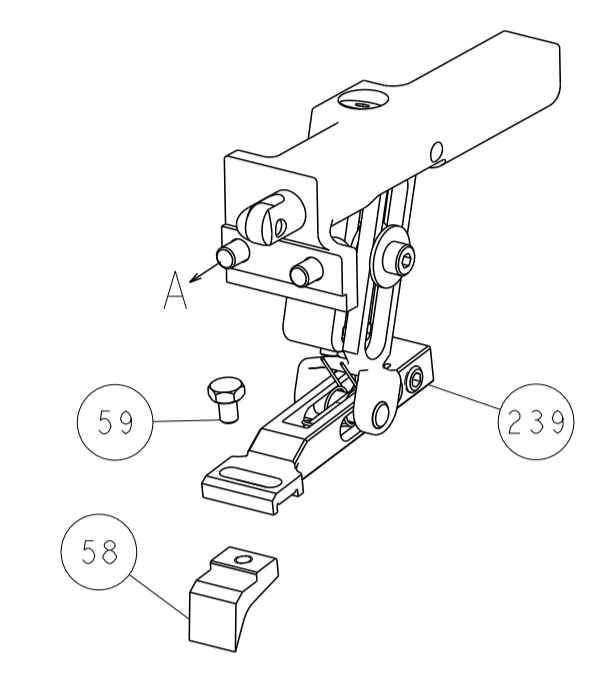

PNEUMATIC

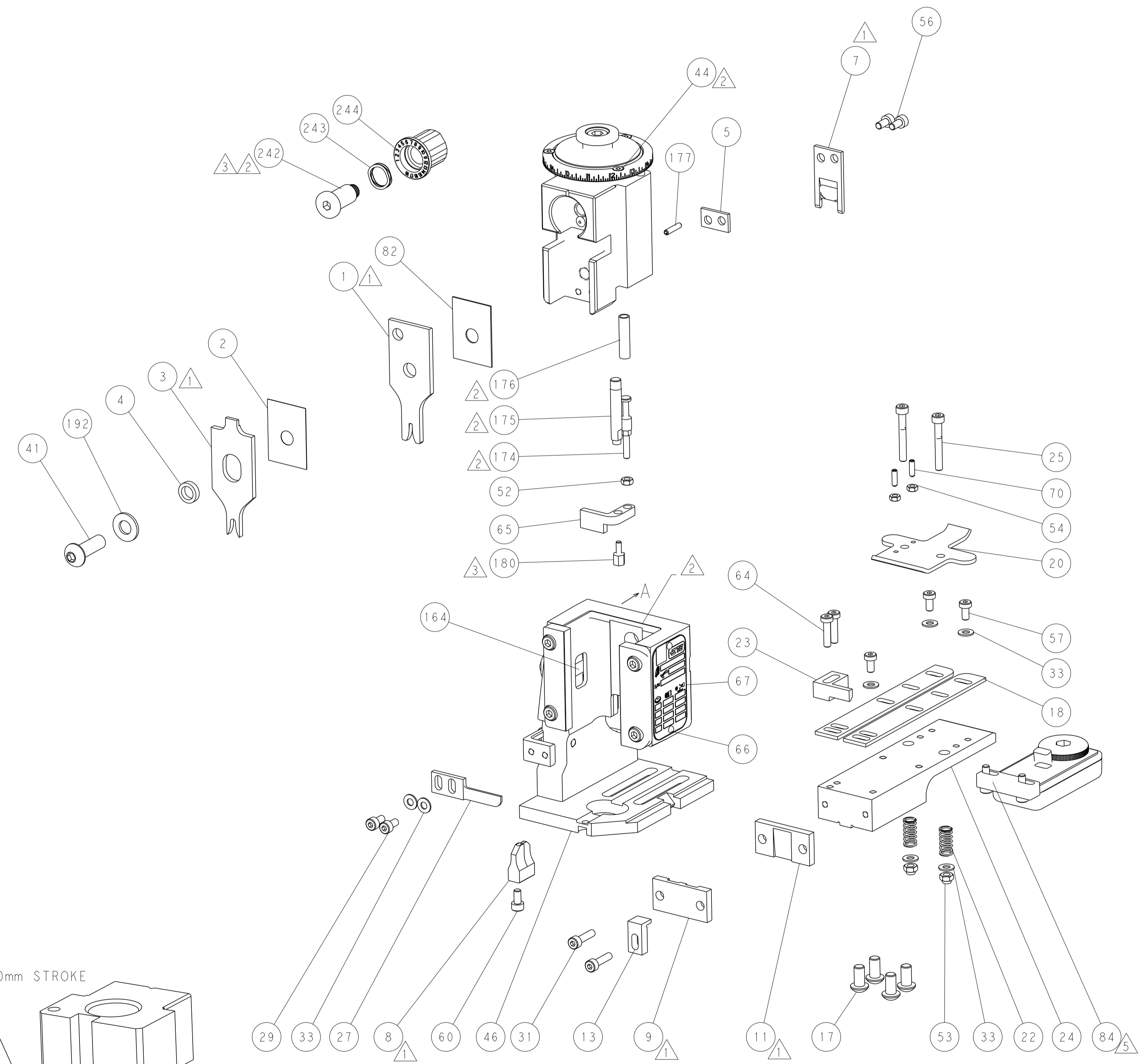
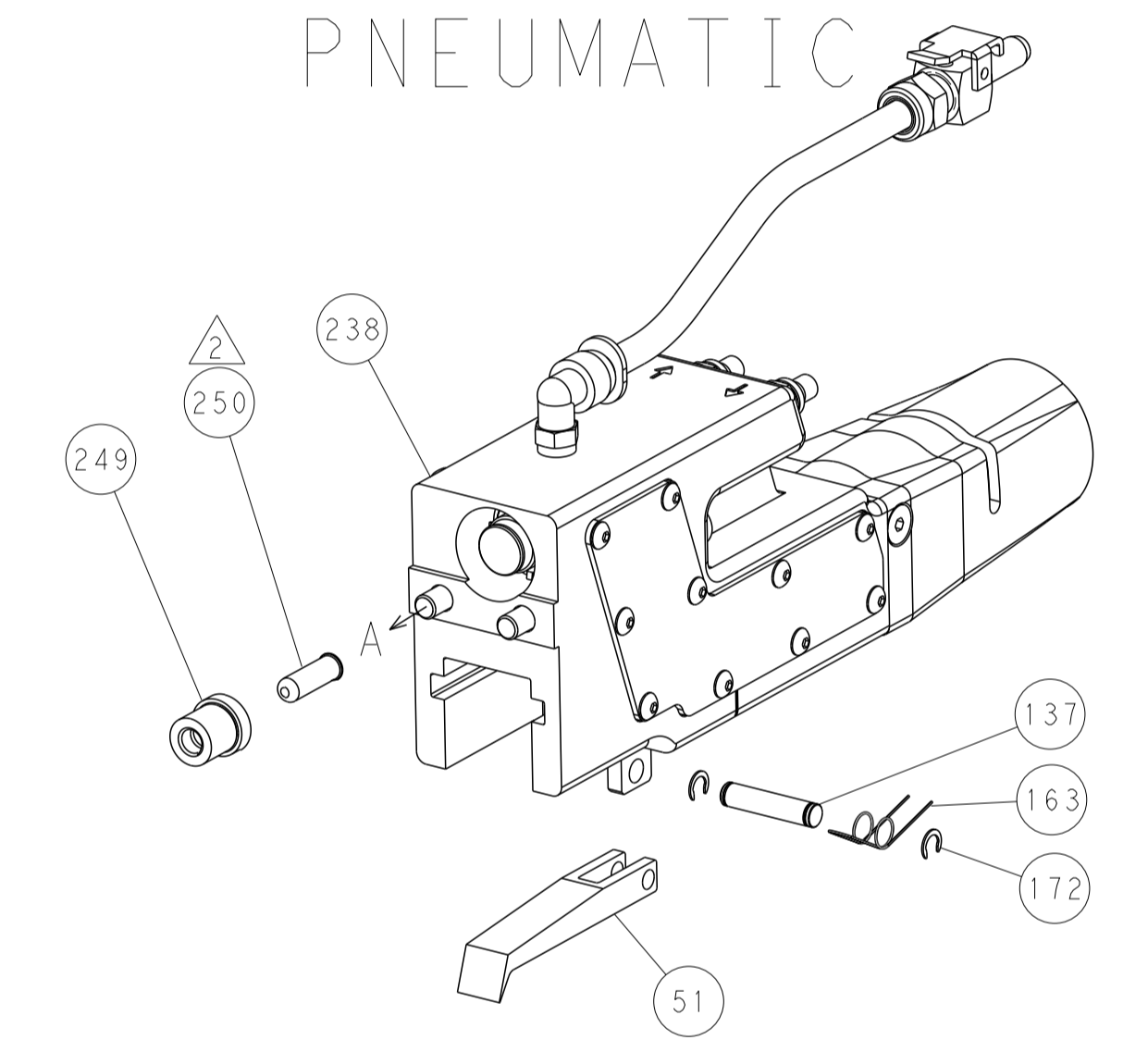

CAM POSITIONS

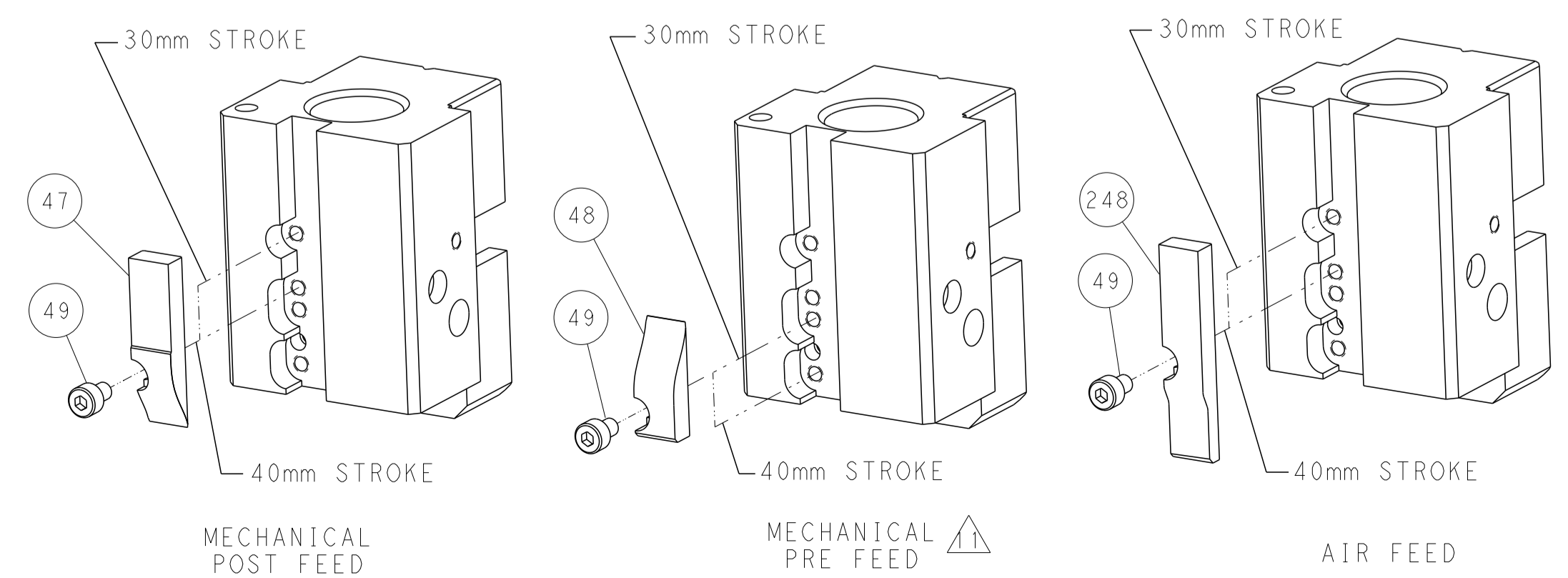

ATLANTIC VERSION
 Shown on sheets 1 of 4 & 2 of 4
 (Pacific version shown on sheets 3 of 4 & 4 of 4)

| | | | |
|---|---|---|--|
| <small>THIS DRAWING IS UNPUBLISHED. RELEASED FOR PUBLICATION BY TYCO ELECTRONICS CORPORATION. ALL RIGHTS RESERVED.</small> | | OWN: M. ZHAO 14MAR2017 CHK: K. ZHANG 14MAR2017 APVD: K. ZHANG 14MAR2017 | TE Connectivity Harrisburg, PA 17105-3608 |
| DIMENSIONS: mm TOLERANCES UNLESS OTHERWISE SPECIFIED: 0 PLC ± 1 PLC ± 2 PLC ± 3 PLC ± 4 PLC ± ANGLES ° ± FINISH | NAME: Ocean End Feed Applicator SIZE: A1 CAGE CODE: 00779 DRAWING NO: C-2150787 SCALE: 1:1 SHEET: 2 of 4 REV: B | RESTRICTED TO: | CUSTOMER ACCESSIBLE PRODUCTION DRAWING |

| PART NUMBER | REVISION | DESCRIPTION | FEED TYPE |
|-------------|----------|--------------------------|------------|
| 2-2150787-1 | B | FINE CRIMP HEIGHT ADJUST | MECHANICAL |
| 2-2150787-2 | B | FINE CRIMP HEIGHT ADJUST | PNEUMATIC |
| 7-2150787-7 | A | CRIMP TOOLING KIT | - |

PACIFIC VERSION TERMINATOR
INTERFACE ADAPTER



| APPLICATOR DATA | | |
|--------------------------------|----------------|------|
| CRIMP | SIZE | TYPE |
| WIRE | 2.03 mm [.080] | F |
| INSUL | 3.56 mm [.140] | Q |
| APPL INSTRUCTIONS 408-35043 | | |

| TERMINAL DATA: TE TERMINAL | | TE CRIMP SPECIFICATION | |
|--|-------------|------------------------------|-------------|
| TERMINAL NAME: .093 DIA PIN RECEPTACLE | | | |
| WIRE STRIP LENGTH | | INSULATION DIAMETER RANGE | |
| 3.58-4.34 mm [.141-.171 IN] | | ∅2.29-3.05 mm [.090-.120 IN] | |
| TERMINAL APPLICATION SPECIFICATION | 114-2080 | | |
| TERMINALS APPLIED | | | |
| TE TERMINAL | TE TERMINAL | TE TERMINAL | TE TERMINAL |
| 42101-2 | | | |

| WIRE SIZE | CRIMP HEIGHT mm [INCH] | CRIMP HEIGHT REFERENCE SETTING |
|-----------|----------------------------|--------------------------------|
| 16 AWG | 1.73+/-0.05 [.068+/-0.002] | 7.9 |
| 18 AWG | 1.52+/-0.05 [.060+/-0.002] | 10.1 |

- RECOMMENDED SPARE PARTS
- REFER TO SUPPLIED INSTRUCTION SHEET FOR CLEANING, LUBRICATION AND STORAGE OF APPLICATOR.
- APPLY PART NUMBER 2-23419-6 LOCTITE TO THREADS OF ITEM 242. APPLY PART NUMBER 1-23419-5 LOCTITE TO THREADS OF ITEM 180.
- CRIMP HEIGHT REFERENCE SETTING WAS THE SETTING USED WHEN THE APPLICATOR WAS QUALIFIED AT THE FACTORY. ADJUSTMENT MAY BE NECESSARY WHEN RUNNING APPLICATOR IN THE FIELD.
- TERMINAL LUBRICANT IS RECOMMENDED.
- 6. UNLESS SPECIFIED OTHERWISE TORQUE VALUES SHALL BE USED PER DOCUMENT, 101-35000.

***WARNING**
ON INSTALLATION, SET WIRE DISC TO CRIMP HEIGHT REFERENCE SETTING FOR LARGEST WIRE SIZE. CRIMP HEIGHT REFERENCE SETTINGS GREATER THAN THE VALUE SHOWN MAY CAUSE DAMAGE TO THE CRIMP TOOLING. REFER TO THE INSTRUCTION SHEET FOR PROPER SETUP AND ADJUSTMENTS.

| LOC | DIST | REVISIONS | | | | | |
|-----|------|-----------|-----|-------------|------|-----|------|
| A | 66 | P | LTN | DESCRIPTION | DATE | OWN | APVD |
| | | - | - | SEE SHEET 1 | - | - | - |

| | | | | | |
|---|----------|---|-------------|-------------------------------------|---------|
| - | 1 | - | 2119640-1 | PUSH ROD, AIR FEED | 250 |
| - | 1 | - | 1803259-1 | BUSHING, FLANGED | 249 |
| - | 1 | 1 | 2119082-3 | CAM, SNAIL, INSULATION ADJUSTMENT | 244 |
| - | 1 | 1 | 2079764-1 | WASHER, WAVE SPRING, CREST-TO-CREST | 243 |
| | 1 | 1 | 2119083-1 | RETAINER, INSULATION DIAL | 242 |
| - | - | 1 | 2119580-1 | MECHANICAL FEED ASSEMBLY | 239 |
| - | 1 | - | 2063440-1 | AIR FEED MODULE | 238 |
| - | 1 | 1 | 1-18028-0 | WASHER, FLAT, REG M8 | 192 |
| - | 4 | 4 | 2079383-9 | SCR, BHSC, RoHS (M6 X 20) | 186 |
| | 1 | 1 | 1752354-9 | STANDOFF, HOLD-DOWN | 180 |
| - | 1 | 1 | 6-993111-6 | PIN, SLOTTED SPRING 3.0 X 14.0 | 177 |
| - | 1 | 1 | 8-22280-7 | SPRING, COMPRESSION | 176 |
| - | 1 | 1 | 1752353-2 | GUIDE PIN, HOLDDOWN | 175 |
| - | 1 | 1 | 1901680-2 | GUIDE PIN, HOLDDOWN | 174 |
| - | 2 | - | 21045-3 | RING, RETAIN, EXTERN, 3/16 CRESCENT | 172 |
| - | REF REF | | 994970-2 | COUNTER, MAGNETIC | 164 |
| - | 1 | - | 240638-1 | SPRING, FEED FINGER | 163 |
| - | 1 | - | 2119641-2 | FEED CAM, AIR FEED | 152 |
| - | 1 | 1 | 2168083-8 | SCR, SKT HD CAP, RoHS, M4 X 16 | 144 |
| - | - | 1 | 2119653-2 | FEED CAM, POST FEED | 142 |
| - | 1 | 1 | 2119655-6 | APPLICATOR BASIC ASSEMBLY, EF | 141 |
| - | 1 | 1 | 1803518-1 | RAM ASSEMBLY, EF PACIFIC | 140 |
| - | 1 | - | 3-23627-7 | PIN, RETAIN, GRVD, 3/16 X .854 | 137 |
| | 1 | 1 | 2119955-2 | ASSY, LUBRICATOR, END FEED | 84 |
| - | 1 | 1 | 455888-6 | SPACER, CRIMPER | 82 |
| - | 1 | 1 | 1803607-2 | DOCUMENTATION PACKAGE | 71 |
| - | 2 | 2 | 2-18032-2 | SCR, SET, FLT PNT, M3 X 10.0 | 70 |
| - | 1 | 1 | 2119740-1 | TAG, IDENTIFICATION | 67 |
| - | 2 | 2 | 2168078-1 | SCREW, DRIVE, RH, RoHS, 2 x .188 | 66 |
| - | 1 | 1 | 1-1901681-3 | HOLDDOWN, TERMINAL | 65 |
| - | 2 | 2 | 2168400-8 | SHCS, LOW HEAD, RoHS, M4 X 16 | 64 |
| - | - | 1 | 5-18022-5 | SCR, HEX HD CAP, M4 X 6.0 | 59 |
| - | - | 1 | 2063961-1 | FEED FINGER | 58 |
| - | 3 | 3 | 2168400-4 | SHCS, LOW HEAD, RoHS, M4 X 8 | 57 |
| - | 2 | 2 | 2168083-2 | SCR, SKT HD CAP, RoHS, M4 X 8.0 | 56 |
| - | 2 | 2 | 5018030-1 | NUT, HEX, REG, RoHS, M3 | 54 |
| - | 2 | 2 | 986965-8 | NUT, LOCK, HEX, TORQUE (M4) | 53 |
| - | 1 | 1 | 1-5018030-0 | NUT, HEX, REG, RoHS, M3.5 | 52 |
| - | 1 | - | 2119792-1 | PAWL, EF, AIR | 51 |
| - | 1 | 2 | 18023-9 | SCR, SKT HD CAP M4 X 6.0 | 49 |
| - | - | 1 | 2119652-1 | FEED CAM, PRE FEED | 48 |
| - | 1 | 1 | 1803602-1 | SCR, BHSC, RoHS (M8 X 25) | 41 |
| - | 7 | 7 | 1-18028-2 | WASHER, FLAT, REG M4 | 33 |
| - | 2 | 2 | 2168083-8 | SCR, SKT HD CAP, RoHS, M4 X 16 | 31 |
| - | 2 | 2 | 2168083-2 | SCR, SKT HD CAP, RoHS, M4 X 8.0 | 29 |
| - | 1 | 1 | 240639-4 | STRIPPER (MACHINING) | 27 |
| - | 2 | 2 | 1-2168083-5 | SCR, SKT HD CAP, RoHS, M4 X 30 | 25 |
| - | 1 | 1 | 1752371-5 | PLATE, STRIP GUIDE | 24 |
| - | 1 | 1 | 240825-4 | PLATE, STRIP HOLD DOWN | 23 |
| - | 2 | 2 | 2-22281-3 | SPRING, COMPRESSION | 22 |
| - | 1 | 1 | 1803292-4 | DRAG | 20 |
| - | 2 | 2 | 1901259-4 | GUIDE, LOWER STRIP | 18 |
| - | 1 | 1 | 1752360-1 | SPACER, HOLD-DOWN | 13 |
| | 1 | 1 | 240644-9 | PLATE, REAR SHEAR | 11 |
| - | - | - | - | - | 10 |
| | 1 | 1 | 5-690482-7 | PLATE, FRONT SHEAR | 9 |
| | 1 | 1 | 2-1803257-6 | ANVIL, COMBINATION, END FEED | 8 |
| | 1 | 1 | 2217206-4 | BLADE, SLUG | 7 |
| - | - | - | - | - | 6 |
| - | 1 | 1 | 1-240641-1 | SPACER | 5 |
| - | 1 | 1 | 238011-2 | BLOCK, CRIMPER SPACER | 4 |
| | 1 | 1 | 3-1803248-4 | CRIMPER, INSULATION O PREMIUM | 3 |
| - | 1 | 1 | 455888-1 | SPACER, CRIMPER | 2 |
| | 1 | 1 | 5-456405-2 | CRIMPER, WIRE PREMIUM | 1 |
| - | 77-22-21 | | PART NO | DESCRIPTION | ITEM NO |

PACIFIC VERSION
Shown on sheets 3 of 4 & 4 of 4
(Atlantic version shown on sheets 1 of 4 & 2 of 4)

| DIMENSIONS: | | TOLERANCES UNLESS OTHERWISE SPECIFIED: | | MATERIAL: | | FINISH: | | WEIGHT: | | SCALE: | |
|--|---------|--|---------|--|---------|--|--------|--|--|--|--------------|
| mm | 0 PLC ± | 1 PLC ± | 2 PLC ± | 3 PLC ± | 4 PLC ± | ANGLES | FINISH | | | 1:1 | SHEET 3 OF 4 |
| APVD: K. ZHANG | | APVD: K. ZHANG | | APVD: K. ZHANG | | APVD: K. ZHANG | | APVD: K. ZHANG | | APVD: K. ZHANG | |
| DATE: 14MAR2017 | | DATE: 14MAR2017 | | DATE: 14MAR2017 | | DATE: 14MAR2017 | | DATE: 14MAR2017 | | DATE: 14MAR2017 | |
| NAME: K. ZHANG | | NAME: K. ZHANG | | NAME: K. ZHANG | | NAME: K. ZHANG | | NAME: K. ZHANG | | NAME: K. ZHANG | |
| PRODUCT SPEC | | PRODUCT SPEC | | PRODUCT SPEC | | PRODUCT SPEC | | PRODUCT SPEC | | PRODUCT SPEC | |
| APPLICATION SPEC | | APPLICATION SPEC | | APPLICATION SPEC | | APPLICATION SPEC | | APPLICATION SPEC | | APPLICATION SPEC | |
| CAGE CODE | | CAGE CODE | | CAGE CODE | | CAGE CODE | | CAGE CODE | | CAGE CODE | |
| DRAWING NO | | DRAWING NO | | DRAWING NO | | DRAWING NO | | DRAWING NO | | DRAWING NO | |
| RESTRICTED TO | | RESTRICTED TO | | RESTRICTED TO | | RESTRICTED TO | | RESTRICTED TO | | RESTRICTED TO | |
| A1 | | A1 | | A1 | | A1 | | A1 | | A1 | |
| 00779 | | 00779 | | 00779 | | 00779 | | 00779 | | 00779 | |
| C=2150787 | | C=2150787 | | C=2150787 | | C=2150787 | | C=2150787 | | C=2150787 | |
| Customer Accessible Production Drawing | | Customer Accessible Production Drawing | | Customer Accessible Production Drawing | | Customer Accessible Production Drawing | | Customer Accessible Production Drawing | | Customer Accessible Production Drawing | |

| LOC | DIST | REVISIONS | | | | | |
|-----|------|-----------|-----|-------------|------|-----|------|
| A | 66 | P | LTM | DESCRIPTION | DATE | DWN | APVD |
| | | - | - | SEE SHEET 1 | - | - | - |

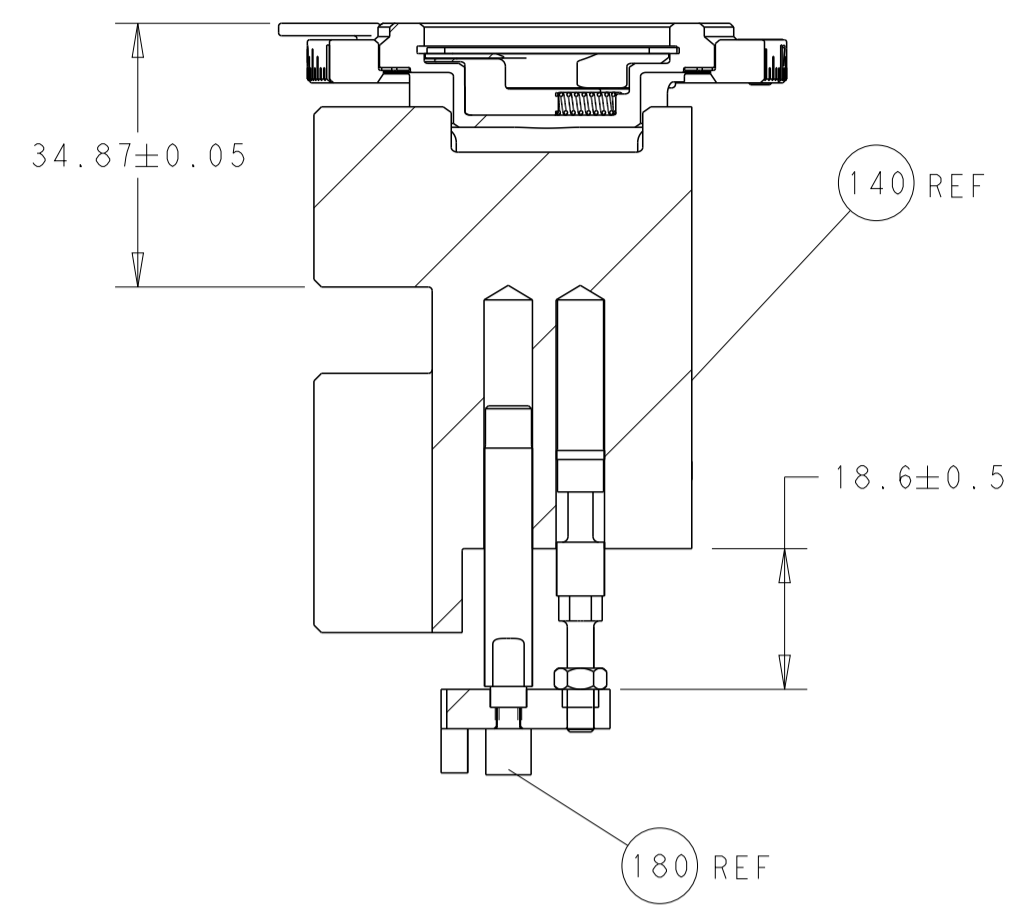

RAM AND HOLDDOWN SET-UP

FEED TYPE
MECHANICAL

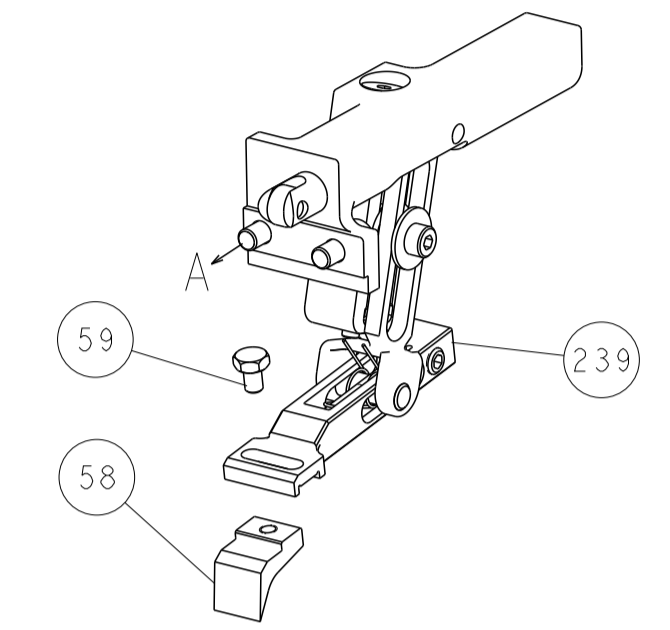

PNEUMATIC

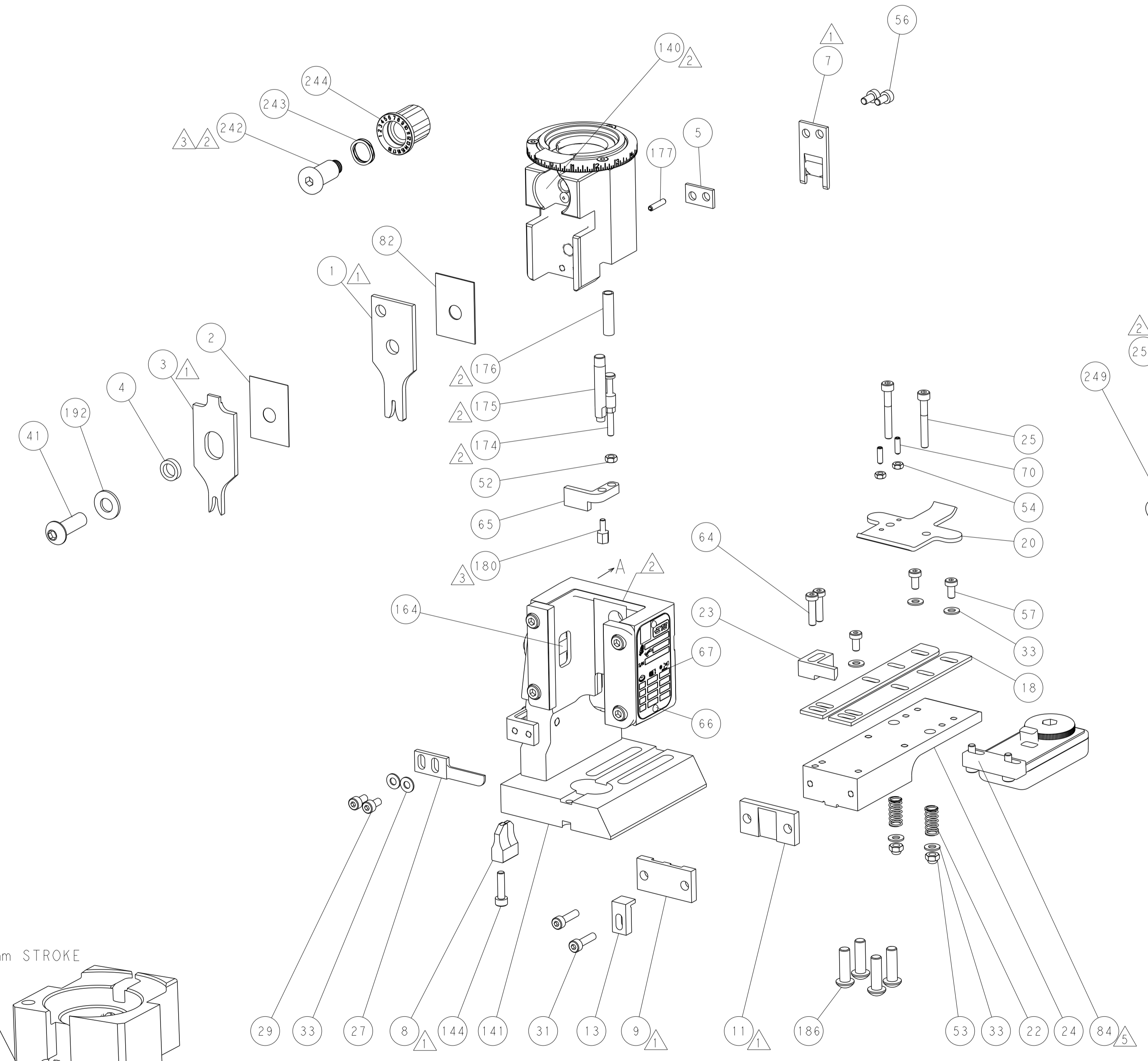
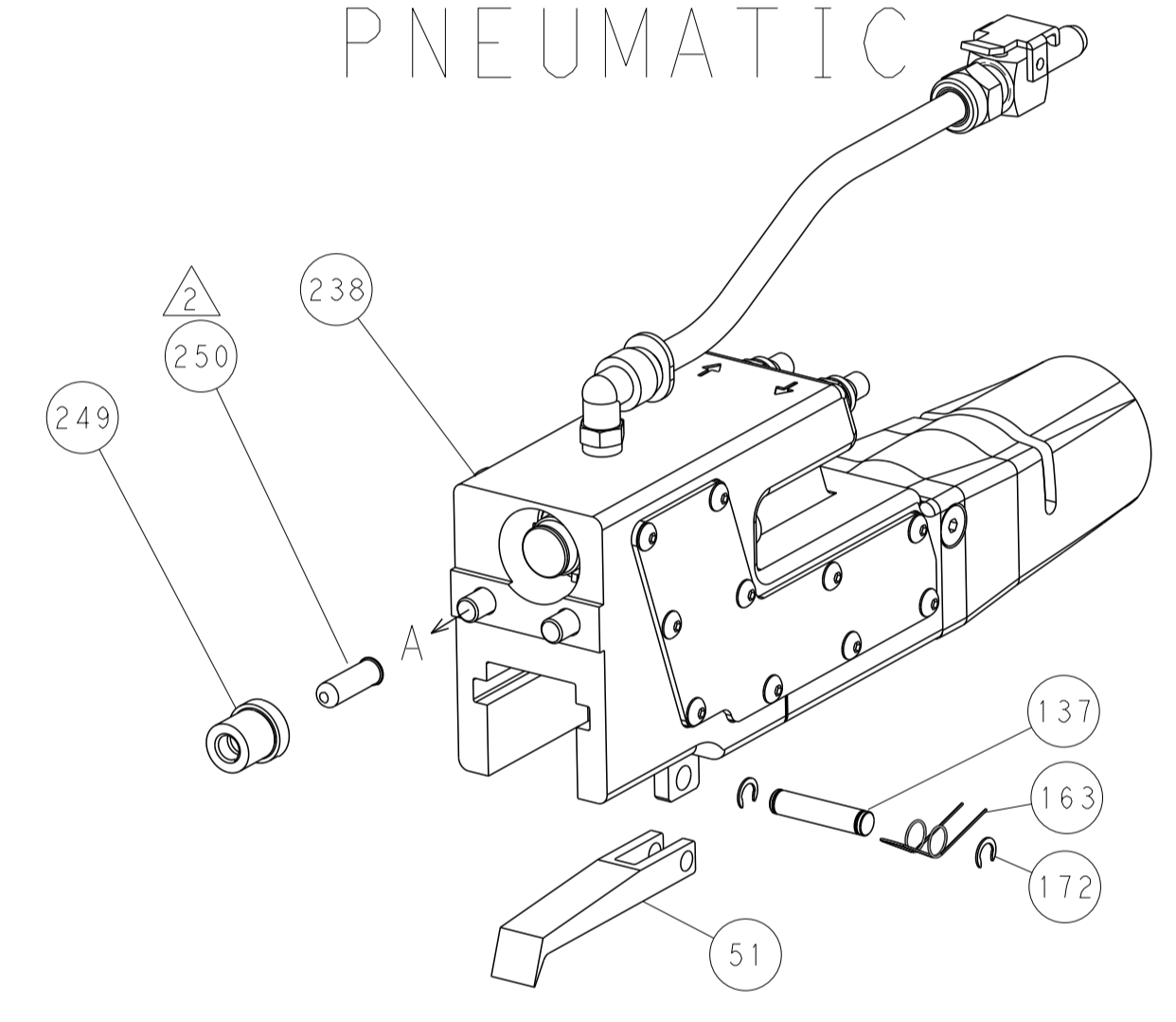

CAM POSITIONS

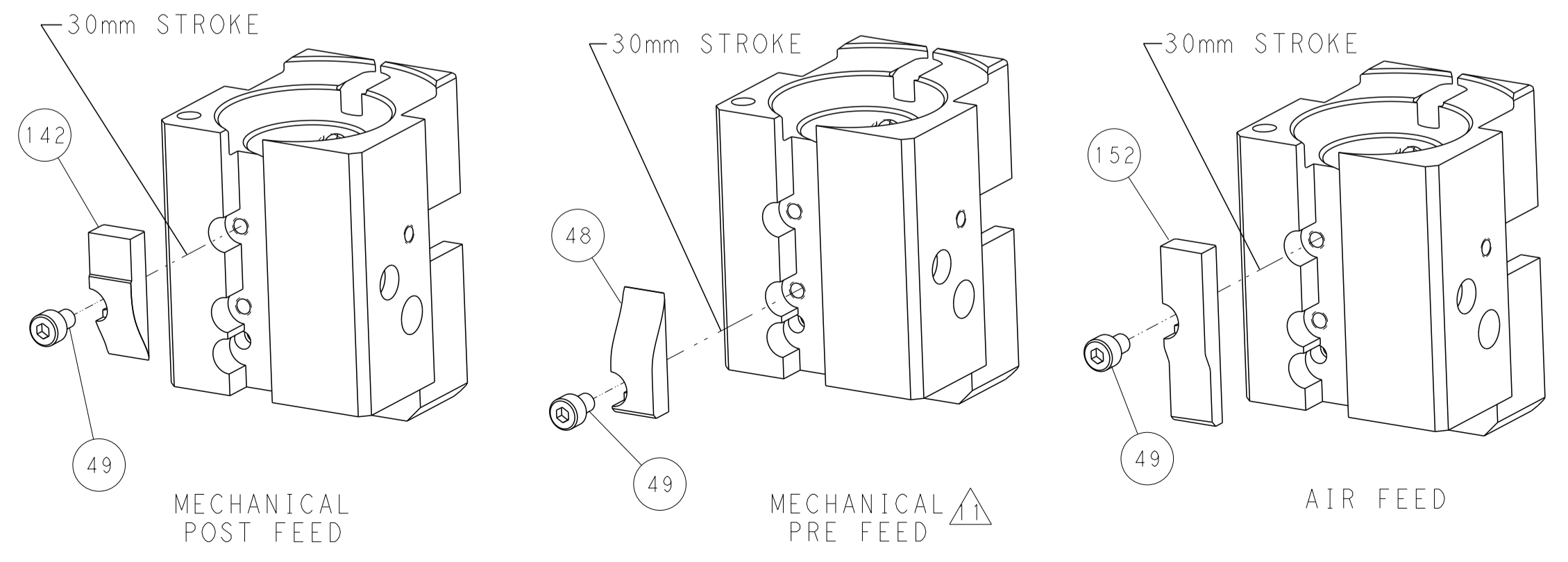

PACIFIC VERSION
 Shown on sheets 3 of 4 & 4 of 4
 (Atlantic version shown on sheets 1 of 4 & 2 of 4)

| | | | | | | | |
|-------------|---------|--|---------|--|---------|------------------------------|--|
| DIMENSIONS: | | TOLERANCES UNLESS OTHERWISE SPECIFIED: | | DWN M. ZHAO 14MAR2017 | | STE TE Connectivity | |
| mm | 0 PLC ± | 1 PLC ± | 2 PLC ± | 3 PLC ± | 4 PLC ± | Harrisburg, PA 17105-3608 | |
| MATERIAL: | | FINISH: | | CHK K. ZHANG 14MAR2017 | | NAME | |
| | | | | APVD K. ZHANG 14MAR2017 | | Ocean End Feed Applicator | |
| | | | | PRODUCT SPEC | | SIZE CAGE CODE DRAWING NO | |
| | | | | APPLICATION SPEC | | A1 00779 C=2150787 | |
| | | | | WEIGHT | | RESTRICTED TO | |
| | | | | Customer Accessible Production Drawing | | SCALE 1:1 SHEET 4 OF 4 REV B | |