

| PART NUMBER | REVISION | DESCRIPTION | FEED TYPE |
|-------------|----------|----------------------------------|------------|
| 2150844-1 | B | FINE CRIMP HEIGHT ADJUST | MECHANICAL |
| 2150844-2 | B | FINE CRIMP HEIGHT ADJUST | PNEUMATIC |
| 7-2150844-1 | B | MECHANICAL AND CRIMP TOOLING KIT | MECHANICAL |
| 7-2150844-2 | B | PNEUMATIC AND CRIMP TOOLING KIT | PNEUMATIC |
| 7-2150844-7 | A | CRIMP TOOLING KIT | - |

ATLANTIC VERSION TERMINATOR INTERFACE ADAPTER

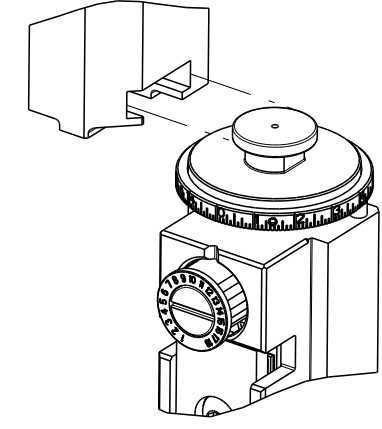

| APPLICATOR DATA | | |
|--------------------------------|----------------|------|
| CRIMP | SIZE | TYPE |
| WIRE | 1.78 mm [.070] | F |
| INSUL | 2.54 mm [.100] | OV |
| APPL INSTRUCTIONS 408-35043 | | |

| TERMINAL DATA: TE TERMINAL | | TE CRIMP SPECIFICATION | |
|---|-------------------|------------------------------|-------------|
| TERMINAL NAME: .250 SERIES FASTIN-FASTON RECEPTACLE | | | |
| WIRE STRIP LENGTH | | INSULATION DIAMETER RANGE | |
| 4.90-5.60 mm [.193-.220 IN] | | Ø1.40-2.30 mm [.055-.091 IN] | |
| TERMINAL APPLICATION SPECIFICATION | APPL DWG 573835-2 | | |
| TERMINALS APPLIED | | | |
| TE TERMINAL | TE TERMINAL | TE TERMINAL | TE TERMINAL |
| 880675-1 | 880675-2 | 880675-3 | |

| WIRE SIZE | CRIMP HEIGHT mm [INCH] | CRIMP HEIGHT REFERENCE SETTING |
|-----------|-------------------------------|--------------------------------|
| 1.00mm2 | 1.52 +/- 0.05 [.060 +/- .002] | 5.7 |
| 0.75mm2 | 1.40 +/- 0.05 [.055 +/- .002] | 7.0 |
| 0.50mm2 | 1.29 +/- 0.05 [.051 +/- .002] | 8.3 |

- 1. RECOMMENDED SPARE PARTS
- 2. REFER TO SUPPLIED INSTRUCTION SHEET FOR CLEANING, LUBRICATION AND STORAGE OF APPLICATOR.
- 3. APPLY PART NUMBER 1-23419-5 LOCTITE TO THREADS OF ITEMS 180. APPLY PART NUMBER 2-23419-6 LOCTITE TO THREADS OF ITEM 242.
- 4. CRIMP HEIGHT REFERENCE SETTING WAS THE SETTING USED WHEN THE APPLICATOR WAS QUALIFIED AT THE FACTORY. ADJUSTMENT MAY BE NECESSARY WHEN RUNNING APPLICATOR IN THE FIELD.
- 5. UNLESS SPECIFIED OTHERWISE TORQUE VALUES SHALL BE USED PER DOCUMENT, 101-35000.

***WARNING**
ON INSTALLATION, SET WIRE DISC TO CRIMP HEIGHT REFERENCE SETTING FOR LARGEST WIRE SIZE. CRIMP HEIGHT REFERENCE SETTINGS GREATER THAN THE VALUE SHOWN MAY CAUSE DAMAGE TO THE CRIMP TOOLING, REFER TO THE INSTRUCTION SHEET FOR PROPER SETUP AND ADJUSTMENTS.

ATLANTIC VERSION
Shown on sheets 1 of 4 & 2 of 4
(Pacific version shown on sheets 3 of 4 & 4 of 4)

| LOC | DIST | REVISIONS | | | | | |
|-----|------|-----------|-----|---------------|-----------|-----|------|
| A | 66 | P | LTN | DESCRIPTION | DATE | DWN | APVD |
| | | A | | RELEASED | 19FEB2018 | BW | TE |
| | | B | | ECR-21-111152 | 23AUG2021 | JAH | RK |

| | | | | | | | | |
|---|-----|-----|-----|-----|-------------|-------------------------------------|-------------------------------------|---------|
| - | 1 | - | 1 | - | 2119641-1 | FEED CAM, AIR FEED | 248 | |
| - | 1 | 1 | 1 | 1 | 2119082-9 | CAM, SNAIL, INSULATION ADJUSTMENT | 244 | |
| - | 1 | 1 | 1 | 1 | 2079764-1 | WASHER, WAVE SPRING, CREST-TO-CREST | 243 | |
| - | 1 | 1 | 1 | 1 | 2119083-1 | RETAINER, INSULATION DIAL | 242 | |
| - | - | 1 | - | 1 | 2119580-1 | MECHANICAL FEED ASSEMBLY | 239 | |
| - | 1 | - | 1 | - | 2844940-3 | AIR FEED MODULE | 238 | |
| - | 1 | 1 | 1 | 1 | 1-18028-0 | WASHER, FLAT, REG M8 | 192 | |
| - | 1 | 1 | 1 | 1 | 1-1976055-3 | STANDOFF, HOLD-DOWN | 180 | |
| - | 1 | 1 | 1 | 1 | 6-9931111-6 | PIN, SLOTTED SPRING 3.0 X 14.0 | 177 | |
| - | 1 | 1 | 1 | 1 | 8-22280-7 | SPRING, COMPRESSION | 176 | |
| - | 1 | 1 | 1 | 1 | 1752353-2 | GUIDE PIN,HOLDDOWN | 175 | |
| - | 1 | 1 | 1 | 1 | 1901680-2 | GUIDE PIN,HOLDDOWN | 174 | |
| - | REF | REF | REF | REF | 994970-2 | COUNTER, MAGNETIC | 164 | |
| - | 1 | 1 | 1 | 1 | 455888-5 | SPACER, CRIMPER | 82 | |
| - | 1 | 1 | 1 | 1 | 1803607-4 | DOCUMENTATION PACKAGE | 71 | |
| - | 2 | 2 | 2 | 2 | 2-18032-2 | SCR, SET, FLT PNT, M3 X 10.0 | 70 | |
| - | 1 | 1 | 1 | 1 | 2119740-1 | TAG, IDENTIFICATION | 67 | |
| - | 2 | 2 | 2 | 2 | 2168078-1 | SCREW, DRIVE, RH, RoHS, 2 x .188 | 66 | |
| - | 1 | 1 | 1 | 1 | 1901681-5 | HOLDDOWN, TERMINAL | 65 | |
| - | 1 | 1 | 1 | 1 | 2168083-2 | SCR, SKT HD CAP, RoHS, M4 X 8.0 | 60 | |
| - | 1 | 1 | 1 | 1 | 5-18022-5 | SCR, HEX HD CAP, M4 X 6.0 | 59 | |
| - | - | 1 | - | 1 | 2063961-3 | FEED FINGER | 58 | |
| - | 4 | 4 | 4 | 4 | 2168400-4 | SHCS, LOW HEAD, RoHS, M4 X 8 | 57 | |
| - | 2 | 2 | 2 | 2 | 1-2168083-0 | SCR, SKT HD CAP, RoHS, M4 X 10 | 56 | |
| - | 2 | 2 | 2 | 2 | 5018030-1 | NUT, HEX, REG, RoHS, M3 | 54 | |
| - | 2 | 2 | 2 | 2 | 986965-8 | NUT, LOCK, HEX, TORQUE (M4) | 53 | |
| - | 1 | 1 | 1 | 1 | 1-5018030-0 | NUT, HEX, REG, RoHS, M3.5 | 52 | |
| - | 1 | - | 1 | - | 1-2063961-8 | FEED FINGER | 51 | |
| - | 1 | 2 | 1 | 2 | 18023-9 | SCR, SKT HD CAP M4 X 6.0 | 49 | |
| - | - | 1 | - | 1 | 2119652-1 | FEED CAM, PRE FEED | 48 | |
| - | - | 1 | - | 1 | 2119653-1 | FEED CAM, POST FEED | 47 | |
| - | 1 | 1 | 1 | 1 | 2119655-5 | APPLICATOR BASIC ASSEMBLY, EF | 46 | |
| - | 1 | 1 | 1 | 1 | 1803517-1 | RAM ASSEMBLY, EF ATLANTIC | 44 | |
| - | 1 | 1 | 1 | 1 | 1803602-1 | SCR, BHSC, RoHS (M8 X 25) | 41 | |
| - | 8 | 8 | 8 | 8 | 1-18028-2 | WASHER, FLAT, REG M4 | 33 | |
| - | 2 | 2 | 2 | 2 | 2168083-9 | SCR, SKT HD CAP, RoHS, M4 X 20 | 31 | |
| - | 2 | 2 | 2 | 2 | 2168083-2 | SCR, SKT HD CAP, RoHS, M4 X 8.0 | 29 | |
| - | 1 | 1 | 1 | 1 | 240639-1 | STRIPPER (MACHINING) | 27 | |
| - | 2 | 2 | 2 | 2 | 1-2168083-5 | SCR, SKT HD CAP, RoHS, M4 X 30 | 25 | |
| - | 1 | 1 | 1 | 1 | 1752371-6 | PLATE, STRIP GUIDE | 24 | |
| - | 2 | 2 | 2 | 2 | 2-22281-3 | SPRING, COMPRESSION | 22 | |
| - | 1 | 1 | 1 | 1 | 1803292-4 | DRAG | 20 | |
| - | 1 | 1 | 1 | 1 | 1803152-1 | STRIP GUIDE, REAR | 19 | |
| - | 1 | 1 | 1 | 1 | 1803151-1 | STRIP GUIDE, FRONT | 18 | |
| - | 4 | 4 | 4 | 4 | 1-2079383-1 | SCR, BHSC, RoHS (M6 X 12) | 17 | |
| - | 1 | 1 | 1 | 1 | 1752360-1 | SPACER,HOLD-DOWN | 13 | |
| - | 1 | 1 | 1 | 1 | 240833-4 | PLATE, REAR SHEAR | 11 | |
| - | - | - | - | - | - | - | 10 | |
| - | 1 | 1 | 1 | 1 | 1-690495-2 | PLATE, FRONT SHEAR | 9 | |
| - | 1 | 2 | 2 | 1 | 1 | 5-1803074-5 | ANVIL, COMBINATION, END FEED | 8 |
| - | 1 | 1 | 1 | 1 | 2217206-6 | BLADE, SLUG | 7 | |
| - | - | - | - | - | - | - | 6 | |
| - | 1 | 1 | 1 | 1 | 240641-4 | SPACER | 5 | |
| - | 1 | 1 | 1 | 1 | 238011-4 | BLOCK, CRIMPER SPACER | 4 | |
| - | 1 | 2 | 2 | 1 | 1 | 2119785-7 | CRIMPER, INSULATION OVERLAP PREMIUM | 3 |
| - | 1 | 1 | 1 | 1 | 455888-5 | SPACER, CRIMPER | 2 | |
| - | 1 | 2 | 2 | 1 | 1 | 7-456404-3 | CRIMPER, WIRE PREMIUM | 1 |
| - | 77 | 72 | 71 | 2 | -1 | PART NO | DESCRIPTION | ITEM NO |

| DIMENSIONS: | | TOLERANCES UNLESS OTHERWISE SPECIFIED: | | MATERIAL: | | FINISH: | | WEIGHT: | | SCALE: | | SHEET: | | REV: | |
|--|---------|--|---------|-----------|---------|---------|--------|---------|--|--------|-------|-----------|---|------|---|
| mm | 0 PLC ± | 1 PLC ± | 2 PLC ± | 3 PLC ± | 4 PLC ± | ANGLES | FINISH | | | A | 00779 | C=2150844 | 1 | of | 4 |
| Customer Accessible Production Drawing | | | | | | | | | | SCALE | | SHEET | | REV | |

| LOC | DIST | REVISIONS | | | | | |
|-----|------|-----------|-----|-------------|------|-----|------|
| | | P | LTN | DESCRIPTION | DATE | DWN | APVD |
| A | 66 | - | - | SEE SHEET 1 | - | - | - |

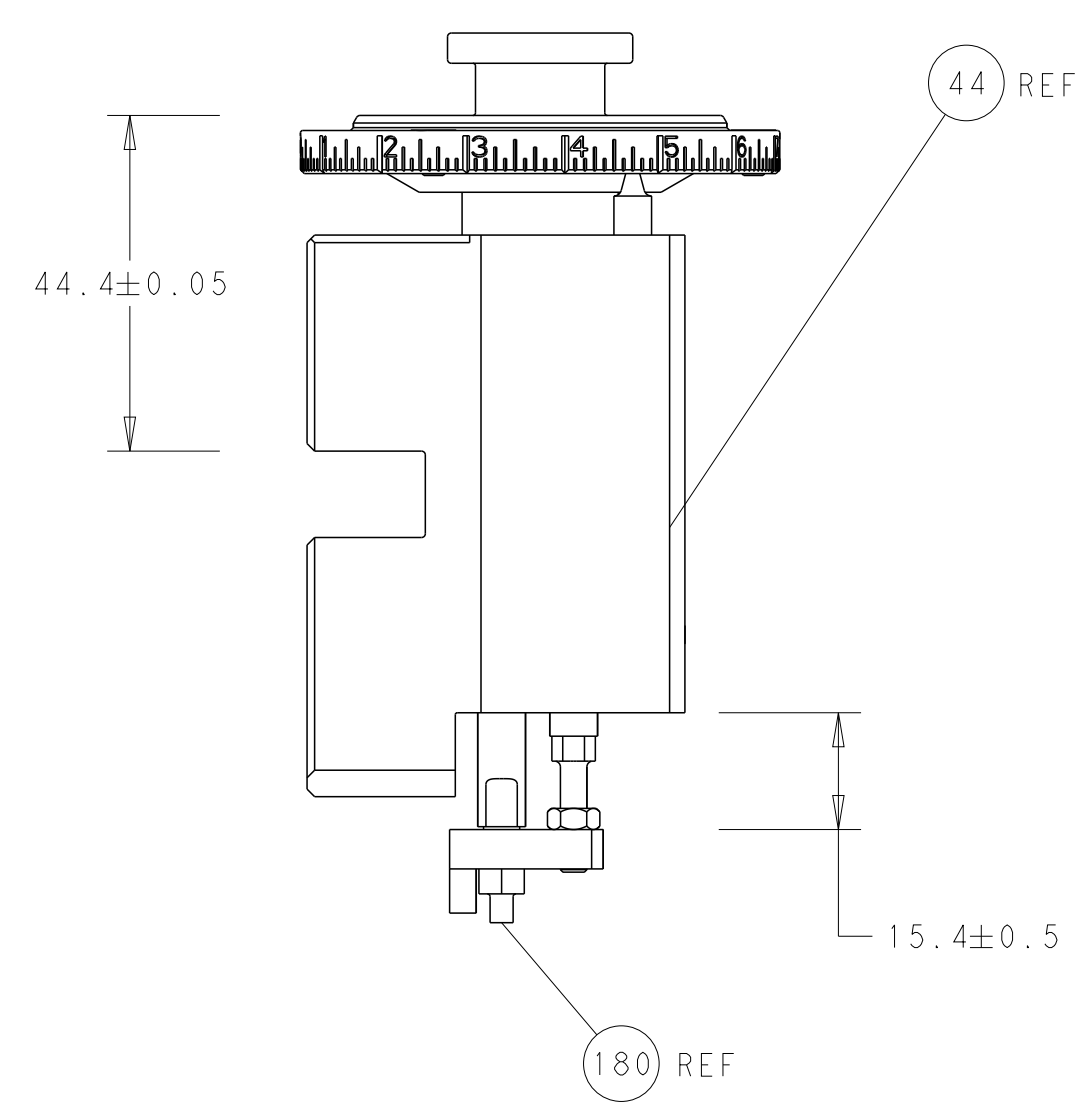

RAM AND HOLDDOWN SET-UP

FEED TYPE
MECHANICAL

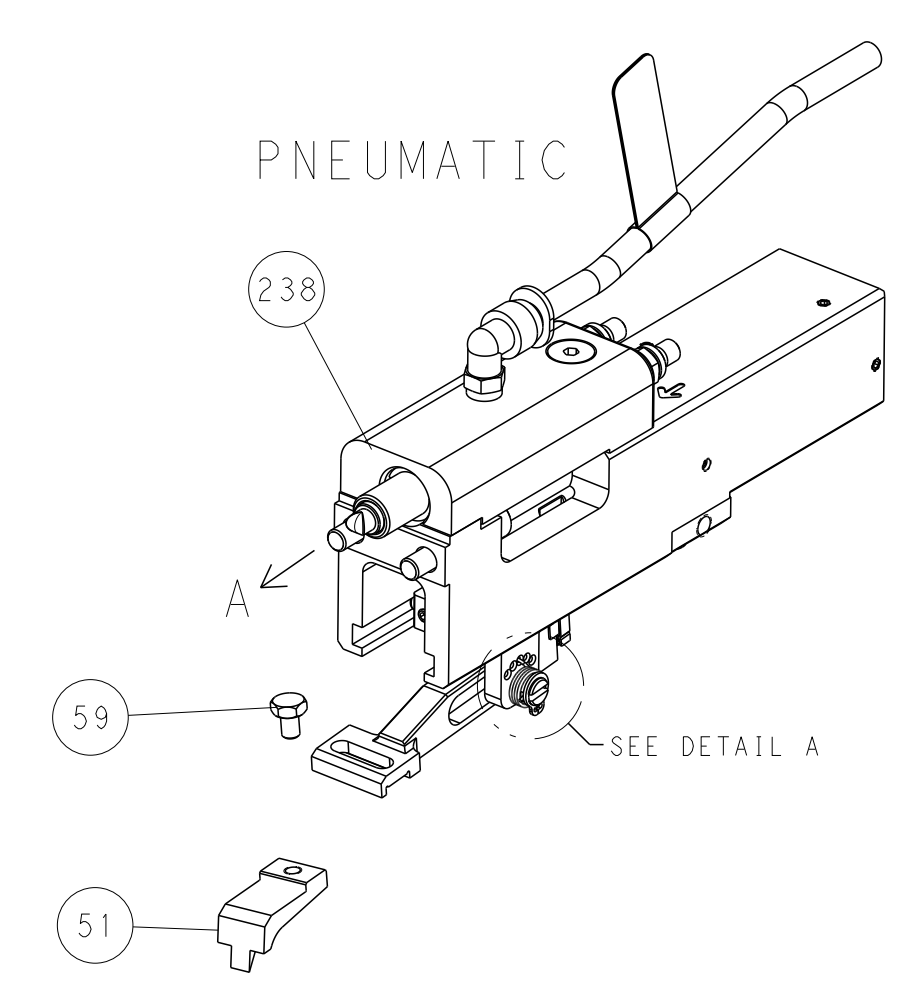
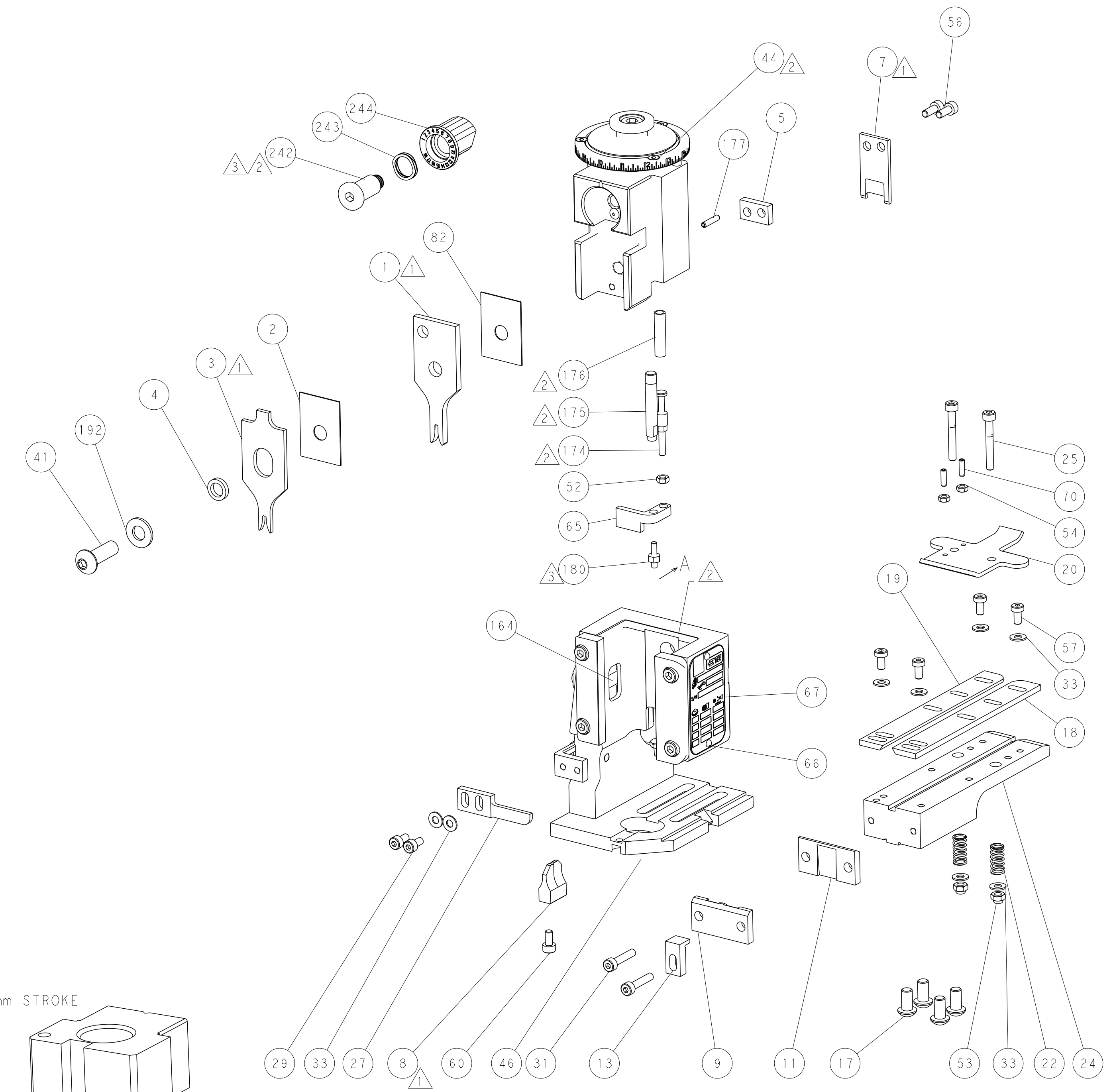
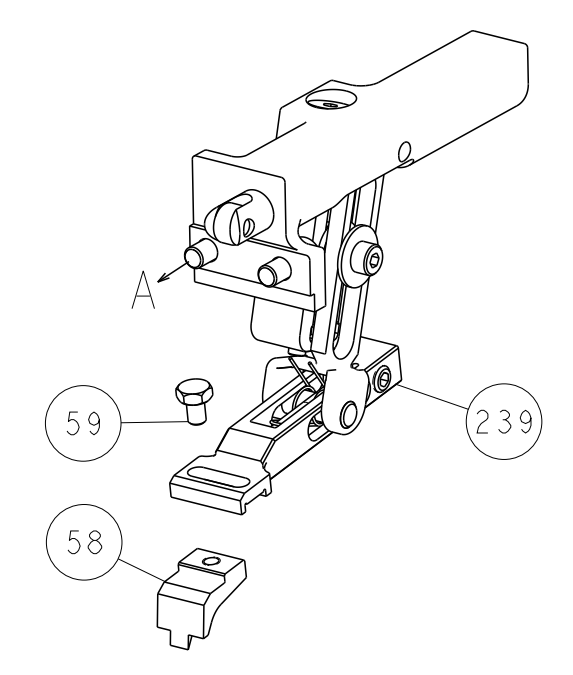

PNEUMATIC

FEED SPRING
SETTING POSITION

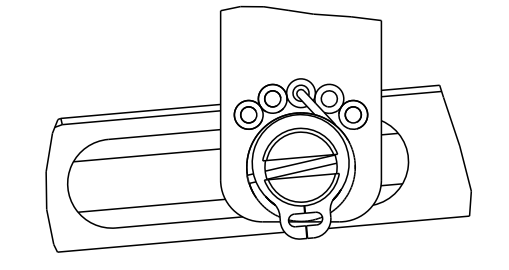

DETAIL A

CAM POSITIONS

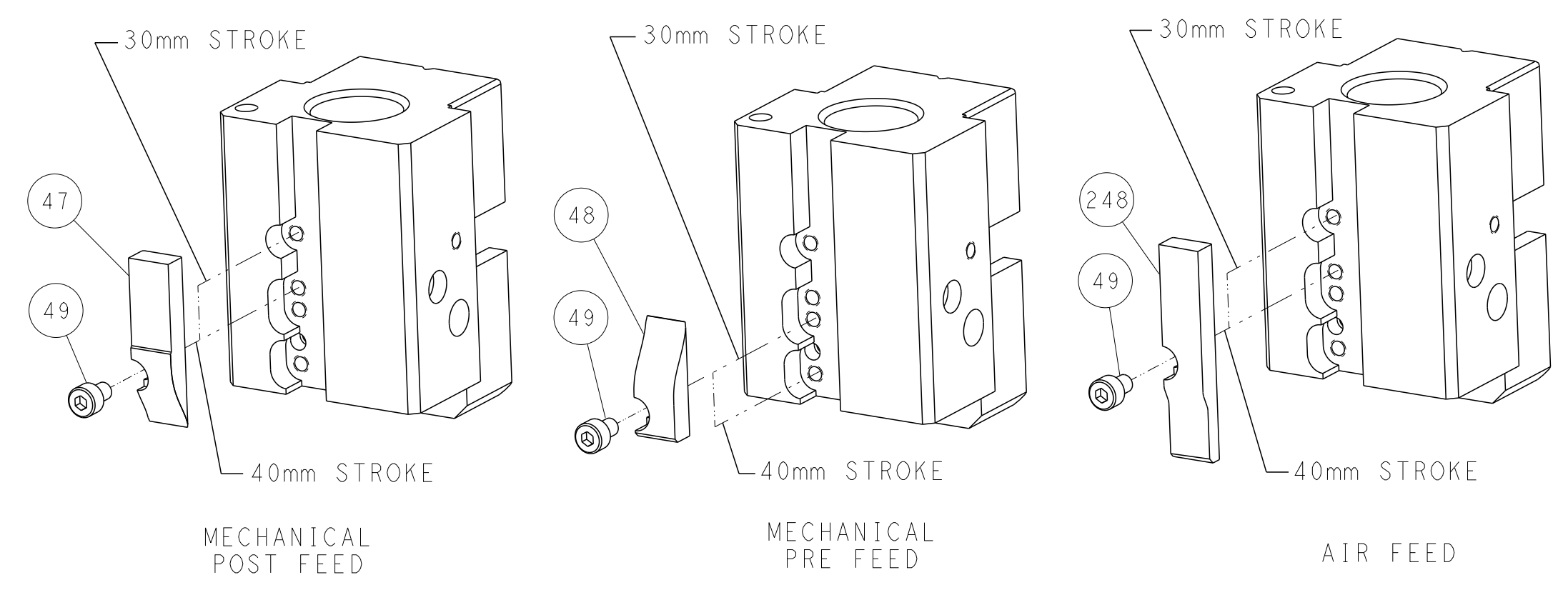

ATLANTIC VERSION
 Shown on sheets 1 of 4 & 2 of 4
 (Pacific version shown on sheets 3 of 4 & 4 of 4)

| | | | | | | |
|--------------------|--|---|--|--|--|--------------------|
| DIMENSIONS: mm | | TOLERANCES UNLESS OTHERWISE SPECIFIED: 0 PLC ± 1 PLC ± 2 PLC ± 3 PLC ± 4 PLC ± ANGLES ± FINISH | | DWN B. WEAVER 07OCT2017 CHK T. ELBIN 07OCT2017 APVD T. ELBIN 07OCT2017 PRODUCT SPEC APPLICATION SPEC WEIGHT Customer Accessible Production Drawing | NAME Ocean End Feed Applicator SIZE CAGE CODE DRAWING NO A1 00779 ©=2150844 SCALE 1:1 SHEET 2 OF 4 REV B | RESTRICTED TO - |
|--------------------|--|---|--|--|--|--------------------|

| PART NUMBER | REVISION | DESCRIPTION | FEED TYPE |
|-------------|----------|--------------------------|------------|
| 2-2150844-1 | B | FINE CRIMP HEIGHT ADJUST | MECHANICAL |
| 2-2150844-2 | B | FINE CRIMP HEIGHT ADJUST | PNEUMATIC |
| 7-2150844-7 | A | CRIMP TOOLING KIT | - |

PACIFIC VERSION TERMINATOR
INTERFACE ADAPTER

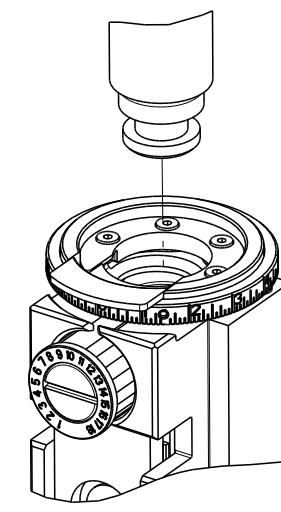

| APPLICATOR DATA | | |
|--------------------------------|----------------|------|
| CRIMP | SIZE | TYPE |
| WIRE | 1.78 mm (.070) | F |
| INSUL | 2.54 mm (.100) | OV |
| APPL INSTRUCTIONS 408-35043 | | |

| TERMINAL DATA: TE TERMINAL | | TE CRIMP SPECIFICATION | |
|---|-------------|---|-------------|
| TERMINAL NAME: .250 SERIES FASTIN-FASTON RECEPTACLE | | | |
| WIRE STRIP LENGTH 4.90-5.60 mm (.193-.220 IN) | | INSULATION DIAMETER RANGE Ø1.40-2.30 mm (.055-.091 IN) | |
| TERMINAL APPLICATION SPECIFICATION APPL DWG 573835-2 | | | |
| TERMINALS APPLIED | | | |
| TE TERMINAL | TE TERMINAL | TE TERMINAL | TE TERMINAL |
| 880675-1 | 880675-2 | 880675-3 | |

| WIRE SIZE | CRIMP HEIGHT mm [INCH] | CRIMP HEIGHT REFERENCE SETTING |
|---------------------|-------------------------------|--------------------------------|
| 1.00mm ² | 1.52 +/- 0.05 [.060 +/- .002] | 5.7 |
| 0.75mm ² | 1.40 +/- 0.05 [.055 +/- .002] | 7.0 |
| 0.50mm ² | 1.29 +/- 0.05 [.051 +/- .002] | 8.3 |

- RECOMMENDED SPARE PARTS
- REFER TO SUPPLIED INSTRUCTION SHEET FOR CLEANING, LUBRICATION AND STORAGE OF APPLICATOR.
- APPLY PART NUMBER 1-23419-5 LOCTITE TO THREADS OF ITEMS 180. APPLY PART NUMBER 2-23419-6 LOCTITE TO THREADS OF ITEM 242.
- CRIMP HEIGHT REFERENCE SETTING WAS THE SETTING USED WHEN THE APPLICATOR WAS QUALIFIED AT THE FACTORY. ADJUSTMENT MAY BE NECESSARY WHEN RUNNING APPLICATOR IN THE FIELD.
- UNLESS SPECIFIED OTHERWISE TORQUE VALUES SHALL BE USED PER DOCUMENT, 101-35000.

***WARNING**
ON INSTALLATION, SET WIRE DISC TO CRIMP HEIGHT REFERENCE SETTING FOR LARGEST WIRE SIZE. CRIMP HEIGHT REFERENCE SETTINGS GREATER THAN THE VALUE SHOWN MAY CAUSE DAMAGE TO THE CRIMP TOOLING, REFER TO THE INSTRUCTION SHEET FOR PROPER SETUP AND ADJUSTMENTS.

| LOC | DIST | REVISIONS | | | | | |
|-----|------|-----------|-----|-------------|------|-----|------|
| A | 66 | P | LTN | DESCRIPTION | DATE | OWN | APVD |
| - | - | - | - | SEE SHEET 1 | - | - | - |

| | | | | | | |
|---|-----|-----|-------------|-------------------------------------|-------------|---------|
| - | 1 | 1 | 2119082-9 | CAM, SNAIL, INSULATION ADJUSTMENT | 244 | |
| - | 1 | 1 | 2079764-1 | WASHER, WAVE SPRING, CREST-TO-CREST | 243 | |
| - | 1 | 1 | 2119083-1 | RETAINER, INSULATION DIAL | 242 | |
| - | - | 1 | 2119580-1 | MECHANICAL FEED ASSEMBLY | 239 | |
| - | 1 | - | 2844940-3 | AIR FEED MODULE | 238 | |
| - | 1 | 1 | 1-18028-0 | WASHER, FLAT, REG M8 | 192 | |
| - | 4 | 4 | 2079383-9 | SCR, BHSC, RoHS (M6 X 20) | 186 | |
| - | 1 | 1 | 1-1976055-3 | STANDOFF, HOLD-DOWN | 180 | |
| - | 1 | 1 | 6-993111-6 | PIN, SLOTTED SPRING 3.0 X 14.0 | 177 | |
| - | 1 | 1 | 8-22280-7 | SPRING, COMPRESSION | 176 | |
| - | 1 | 1 | 1752353-2 | GUIDE PIN,HOLDDOWN | 175 | |
| - | 1 | 1 | 1901680-2 | GUIDE PIN,HOLDDOWN | 174 | |
| - | REF | REF | 994970-2 | COUNTER, MAGNETIC | 164 | |
| - | 1 | - | 2119641-2 | FEED CAM, AIR FEED | 152 | |
| - | 1 | 1 | 2168083-8 | SCR, SKT HD CAP, RoHS, M4 X 16 | 144 | |
| - | - | 1 | 2119653-2 | FEED CAM, POST FEED | 142 | |
| - | 1 | 1 | 2119655-6 | APPLICATOR BASIC ASSEMBLY, EF | 141 | |
| - | 1 | 1 | 1803518-1 | RAM ASSEMBLY, EF PACIFIC | 140 | |
| - | 1 | 1 | 455888-5 | SPACER, CRIMPER | 82 | |
| - | 1 | 1 | 1803607-4 | DOCUMENTATION PACKAGE | 71 | |
| - | 2 | 2 | 2-18032-2 | SCR, SET, FLT PNT, M3 X 10.0 | 70 | |
| - | 1 | 1 | 2119740-1 | TAG, IDENTIFICATION | 67 | |
| - | 2 | 2 | 2168078-1 | SCREW, DRIVE, RH, RoHS, 2 x .188 | 66 | |
| - | 1 | 1 | 1901681-5 | HOLDDOWN, TERMINAL | 65 | |
| - | 1 | 1 | 5-18022-5 | SCR, HEX HD CAP, M4 X 6.0 | 59 | |
| - | - | 1 | 2063961-3 | FEED FINGER | 58 | |
| - | 4 | 4 | 2168400-4 | SHCS, LOW HEAD, RoHS, M4 X 8 | 57 | |
| - | 2 | 2 | 1-2168083-0 | SCR, SKT HD CAP, RoHS, M4 X 10 | 56 | |
| - | 2 | 2 | 5018030-1 | NUT, HEX, REG, RoHS, M3 | 54 | |
| - | 2 | 2 | 986965-8 | NUT, LOCK, HEX, TORQUE (M4) | 53 | |
| - | 1 | 1 | 1-5018030-0 | NUT, HEX, REG, RoHS, M3.5 | 52 | |
| - | 1 | - | 1-2063961-8 | FEED FINGER | 51 | |
| - | 1 | 2 | 18023-9 | SCR, SKT HD CAP M4 X 6.0 | 49 | |
| - | - | 1 | 2119652-1 | FEED CAM, PRE FEED | 48 | |
| - | 1 | 1 | 1803602-1 | SCR, BHSC, RoHS (M8 X 25) | 41 | |
| - | 8 | 8 | 1-18028-2 | WASHER, FLAT, REG M4 | 33 | |
| - | 2 | 2 | 2168083-9 | SCR, SKT HD CAP, RoHS, M4 X 20 | 31 | |
| - | 2 | 2 | 2168083-2 | SCR, SKT HD CAP, RoHS, M4 X 8.0 | 29 | |
| - | 1 | 1 | 240639-1 | STRIPPER (MACHINING) | 27 | |
| - | 2 | 2 | 1-2168083-5 | SCR, SKT HD CAP, RoHS, M4 X 30 | 25 | |
| - | 1 | 1 | 1752371-6 | PLATE, STRIP GUIDE | 24 | |
| - | 2 | 2 | 2-22281-3 | SPRING, COMPRESSION | 22 | |
| - | 1 | 1 | 1803292-4 | DRAG | 20 | |
| - | 1 | 1 | 1803152-1 | STRIP GUIDE, REAR | 19 | |
| - | 1 | 1 | 1803151-1 | STRIP GUIDE, FRONT | 18 | |
| - | 1 | 1 | 1752360-1 | SPACER,HOLD-DOWN | 13 | |
| - | 1 | 1 | 240833-4 | PLATE, REAR SHEAR | 11 | |
| - | - | - | - | - | 10 | |
| - | 1 | 1 | 1-690495-2 | PLATE, FRONT SHEAR | 9 | |
| - | 1 | 1 | 5-1803074-5 | ANVIL, COMBINATION, END FEED | 8 | |
| - | 1 | 1 | 2217206-6 | BLADE, SLUG | 7 | |
| - | - | - | - | - | 6 | |
| - | 1 | 1 | 240641-4 | SPACER | 5 | |
| - | 1 | 1 | 238011-4 | BLOCK, CRIMPER SPACER | 4 | |
| - | 1 | 1 | 2119785-7 | CRIMPER, INSULATION OVERLAP PREMIUM | 3 | |
| - | 1 | 1 | 455888-5 | SPACER, CRIMPER | 2 | |
| - | 1 | 1 | 7-456404-3 | CRIMPER, WIRE PREMIUM | 1 | |
| - | 77 | 22 | 21 | PART NO | DESCRIPTION | ITEM NO |

PACIFIC VERSION
Shown on sheets 3 of 4 & 4 of 4
(Atlantic version shown on sheets 1 of 4 & 2 of 4)

| DIMENSIONS: | | TOLERANCES UNLESS OTHERWISE SPECIFIED: | | MATERIAL: | | FINISH: | |
|-------------|---------|--|---------|-----------|---------|---------|--------|
| mm | 0 PLC ± | 1 PLC ± | 2 PLC ± | 3 PLC ± | 4 PLC ± | ANGLES | FINISH |
| WEIGHT | | SCALE | | SHEET | | REV | |
| A | | 1:1 | | 3 OF 4 | | B | |

| LOC | DIST | REV | DESCRIPTION | DATE | OWN | APVD |
|-----|------|-----|-------------|------|-----|------|
| A | 66 | | SEE SHEET 1 | | | |

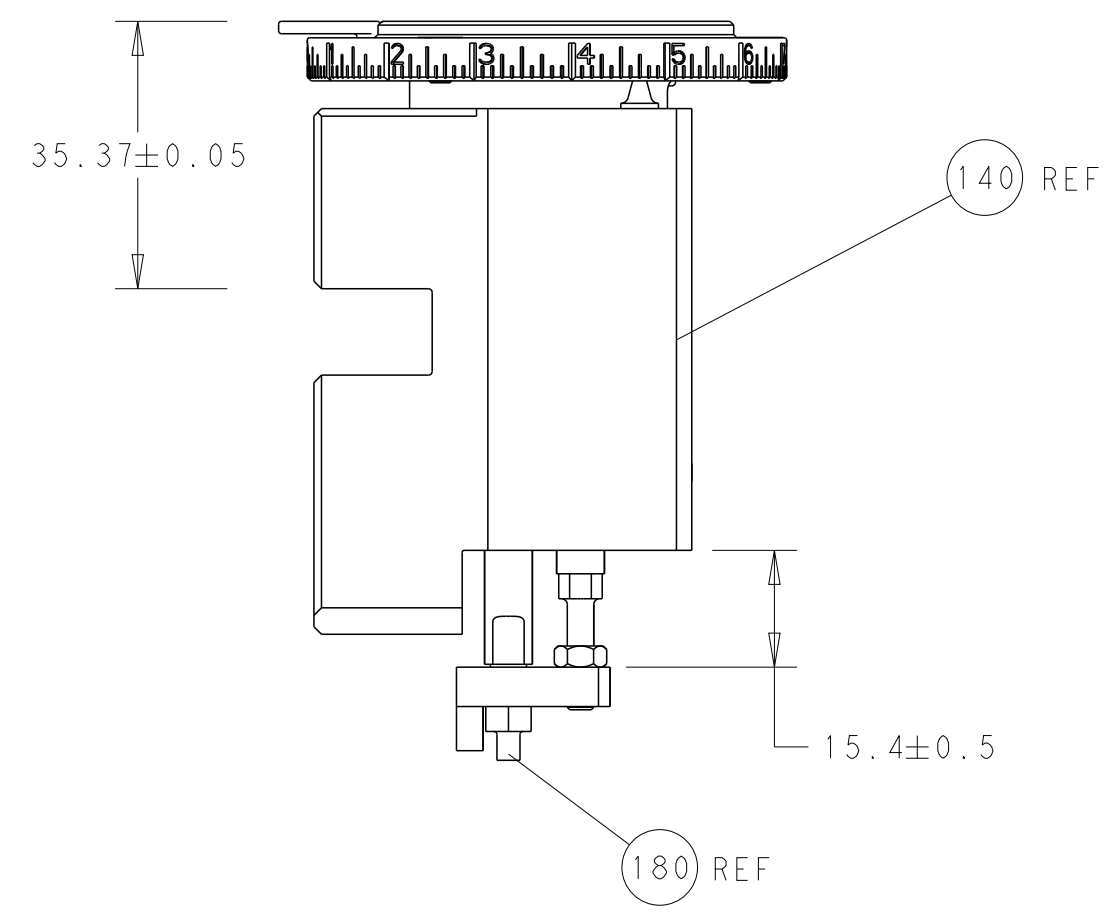

RAM AND HOLDDOWN SET-UP

FEED TYPE
MECHANICAL

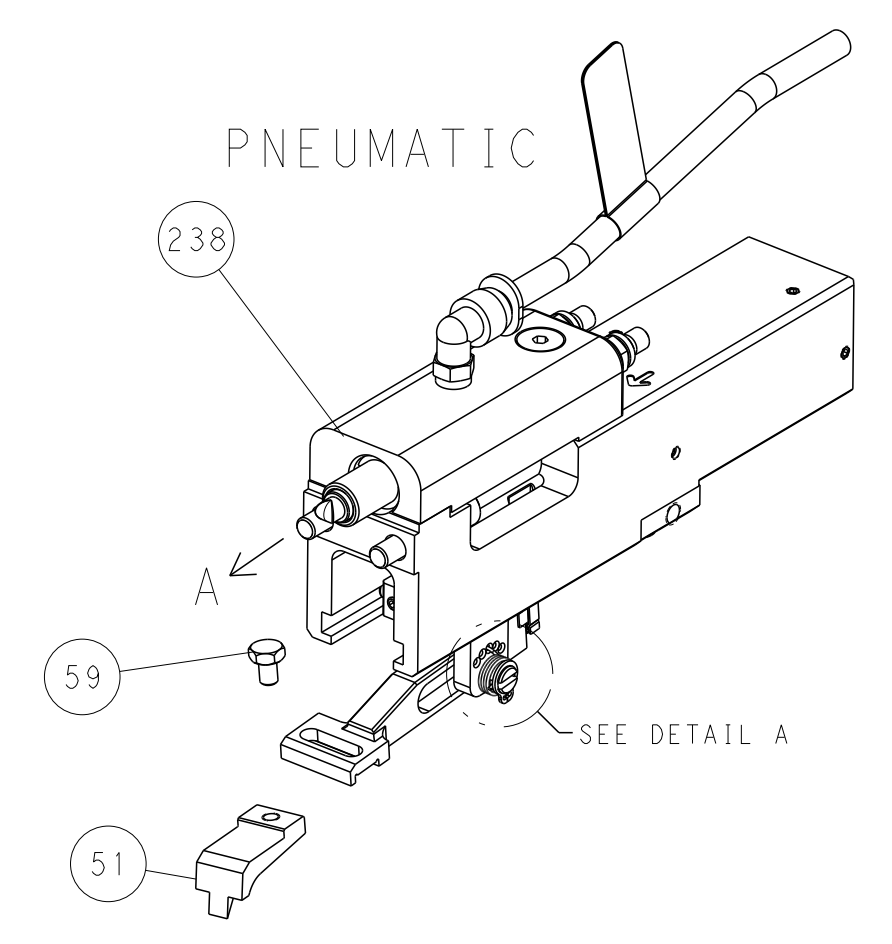
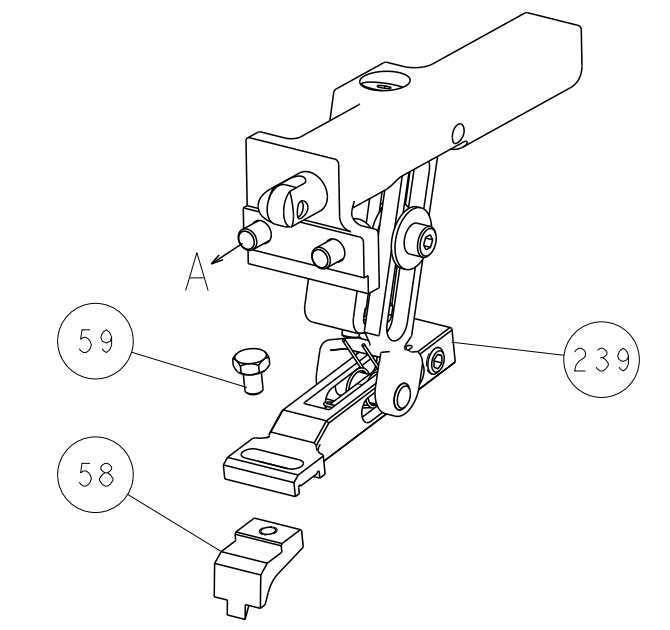

FEED SPRING
SETTING POSITION

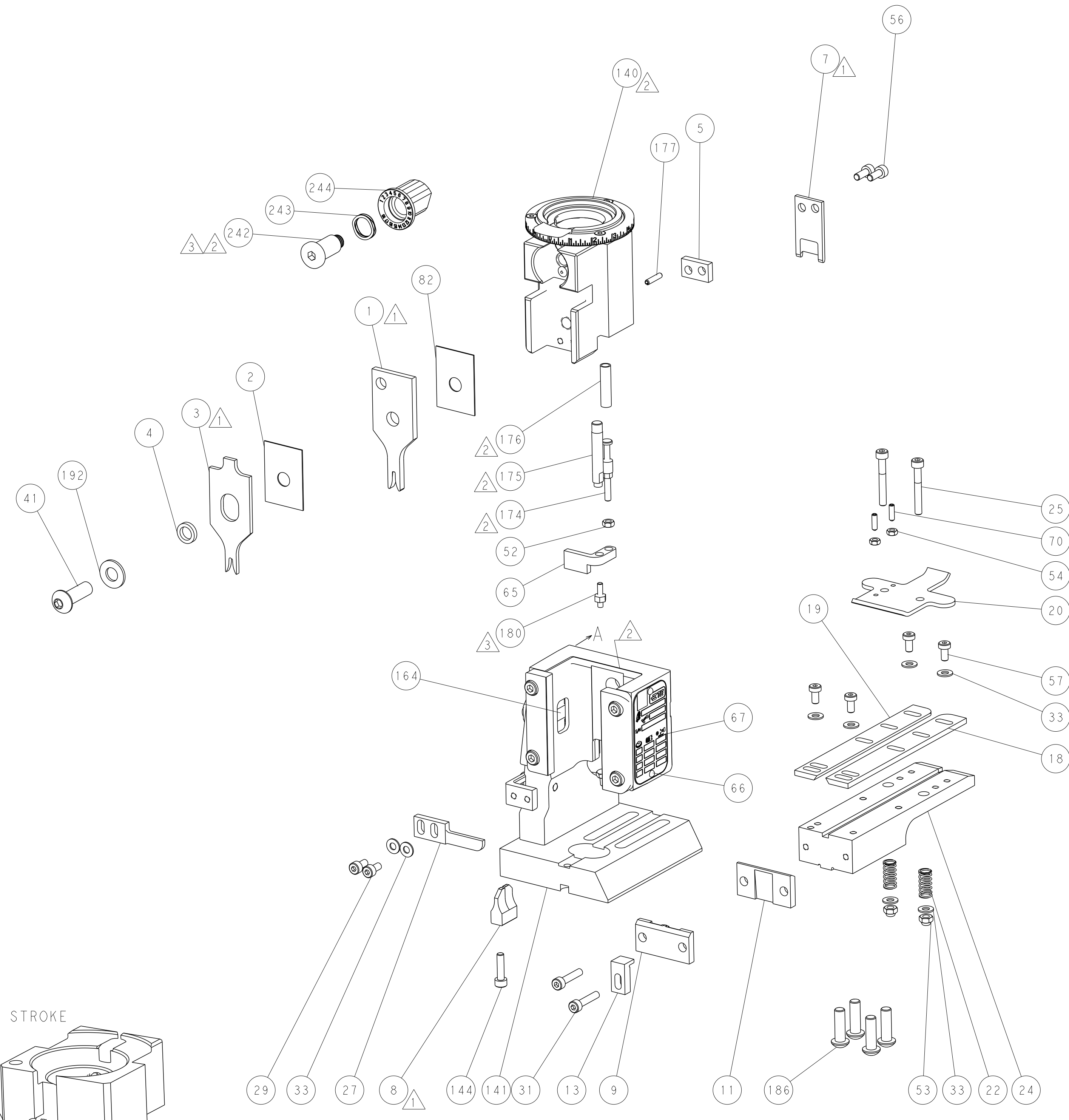
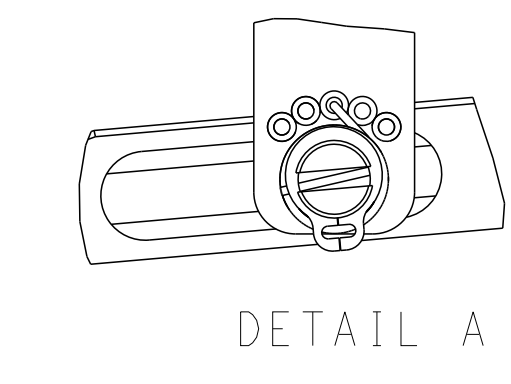

CAM POSITIONS

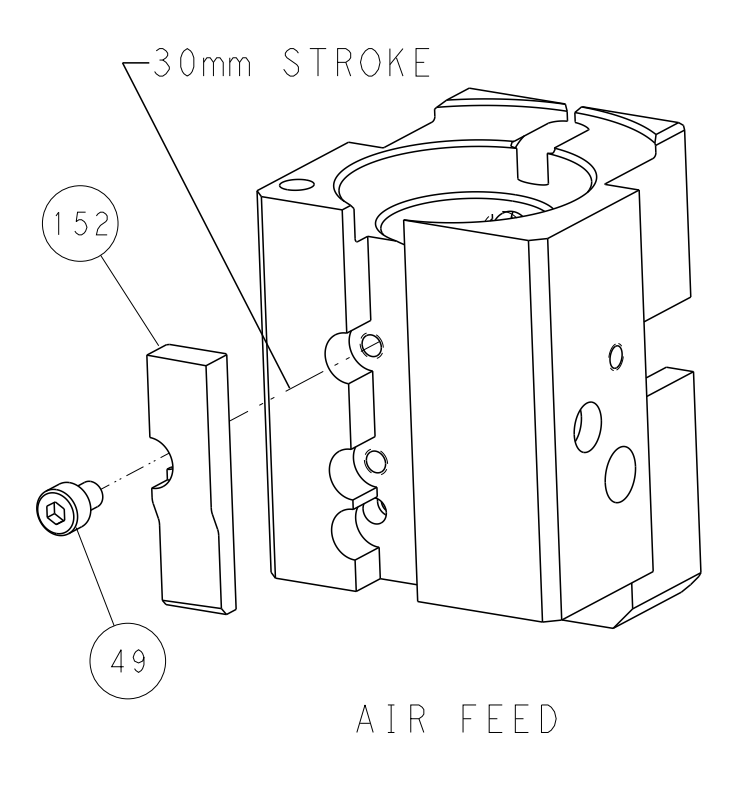
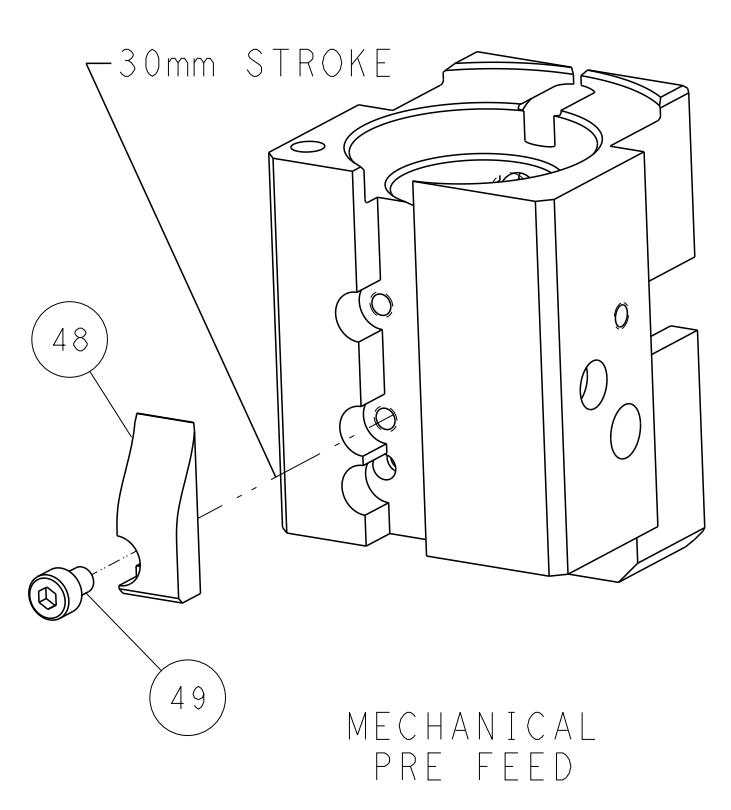
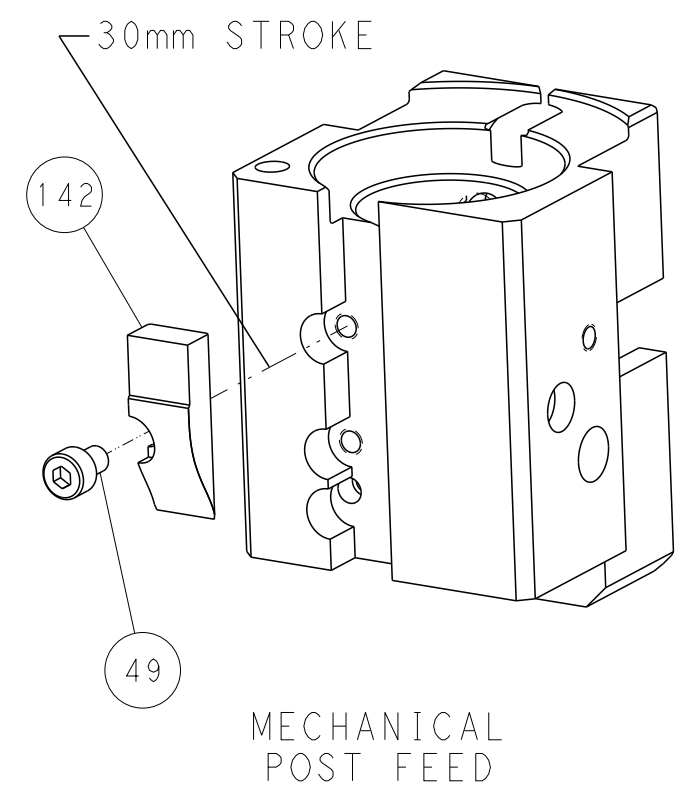

PACIFIC VERSION
 Shown on sheets 3 of 4 & 4 of 4
 (Atlantic version shown on sheets 1 of 4 & 2 of 4)

| | | | | | | | | | |
|-----------------------|--|---|--|--|--|--|--|------------------------------|--|
| DIMENSIONS: mm | | TOLERANCES UNLESS OTHERWISE SPECIFIED: 0 PLC ± 1 PLC ± 2 PLC ± 3 PLC ± 4 PLC ± ANGLES ± FINISH | | DWN B. WEAVER 07OCT2017 CHK T. ELBIN 07OCT2017 APVD T. ELBIN 07OCT2017 PRODUCT SPEC APPLICATION SPEC WEIGHT Customer Accessible Production Drawing | | NAME Ocean End Feed Applicator SIZE CAGE CODE DRAWING NO A 00779 C=2150844 SCALE 1:1 SHEET 4 OF 4 REV B | | RESTRICTED TO - - - | |
|-----------------------|--|---|--|--|--|--|--|------------------------------|--|