

PART NUMBER	REVISION	DESCRIPTION	FEED TYPE
2151070-1	K	FINE CRIMP HEIGHT ADJUST	MECHANICAL
2151070-2	K	FINE CRIMP HEIGHT ADJUST	PNEUMATIC
7-2151070-7	A	CRIMP TOOLING KIT	-

ATLANTIC VERSION TERMINATOR
INTERFACE ADAPTER

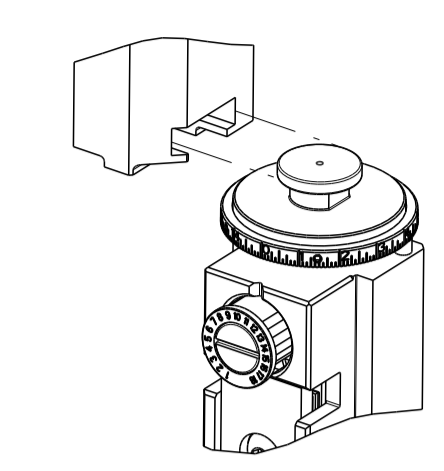

APPLICATOR DATA		
CRIMP	SIZE	TYPE
WIRE	3.30 mm [.130]	F
INSUL	4.57 mm [.180]	OV

APPLICATOR INSTRUCTIONS
408-35042

TERMINAL DATA: TE TERMINAL		TE CRIMP SPECIFICATION	
TERMINAL NAME: STANDARD POWER TIMER CONTACT			
WIRE STRIP LENGTH		INSULATION DIAMETER RANGE	
4.40-5.00 mm [.173-.197 IN]		Ø3.30-4.50 mm [.130-.177 IN]	
TERMINAL APPLICATION SPECIFICATION	(A)114-18037		
	(B)114-18388		
TERMINALS APPLIED			
	TE TERMINAL		TE TERMINAL
(A) 964328-1	(A) 964328-5	(B) 1241406-1	(B) 1241406-3
	TE TERMINAL		TE TERMINAL
(B) 1-2208461-3	(B) 1-2333551-3		

TERMINAL DATA: TE TERMINAL		TE CRIMP SPECIFICATION	
TERMINAL NAME: STANDARD POWER TIMER CONTACT			
WIRE STRIP LENGTH		INSULATION DIAMETER RANGE	
4.40-5.00 mm [.173-.197 IN]		Ø3.30-4.50 mm [.130-.177 IN]	
TERMINAL APPLICATION SPECIFICATION			
TERMINALS APPLIED			
	TE TERMINAL		TE TERMINAL
1241406-1	964328-1		

TERMINAL DATA: TE TERMINAL		TE CRIMP SPECIFICATION	
TERMINAL NAME: STANDARD POWER TIMER CONTACT			
WIRE STRIP LENGTH		INSULATION DIAMETER RANGE	
4.40-5.00 mm [.173-.197 IN]		Ø3.30-4.50 mm [.130-.177 IN]	
TERMINAL APPLICATION SPECIFICATION	(B) 114-18388		
TERMINALS APPLIED			
	TE TERMINAL		TE TERMINAL
(B) 1-2208461-3	(B) 1-2333551-3	(B) 1241406-1	(B) 1241406-3

WIRE SIZE	CRIMP HEIGHT mm [INCH]	CRIMP HEIGHT REFERENCE SETTING
4.00mm2	2.22+/-0.05 [.087+/- .002]	6.1
3.50mm2	2.24+/-0.05 [.088+/- .002]	5.8
3.00mm2	2.13+/-0.05 [.084+/- .002]	7.0

WIRE SIZE	CRIMP HEIGHT mm [INCH]	CRIMP HEIGHT REFERENCE SETTING
1.50mm2+2.50mm2	2.35+/-0.05 [.093+/- .002]	4.3

WIRE SIZE	CRIMP HEIGHT mm [INCH]	CRIMP HEIGHT REFERENCE SETTING
4.0mm2	2.22+/-0.05 [.087+/- .002]	6.1

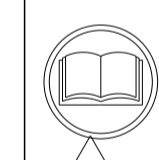

- 1 RECOMMENDED SPARE PARTS
- 2 REFER TO SUPPLIED INSTRUCTION SHEET FOR CLEANING, LUBRICATION AND STORAGE OF APPLICATOR.
- 3 APPLY PART NUMBER 2-23419-6 LOCTITE TO THREADS OF ITEM 242.
- 4 CRIMP HEIGHT REFERENCE SETTING WAS THE SETTING USED WHEN THE APPLICATOR WAS QUALIFIED AT THE FACTORY. ADJUSTMENT MAY BE NECESSARY WHEN RUNNING APPLICATOR IN THE FIELD.
- 5 TERMINAL LUBRICANT IS RECOMMENDED.
- 6. UNLESS SPECIFIED OTHERWISE TORQUE VALUES SHALL BE USED PER DOCUMENT, 101-35000.
- 7 USE ITEM 34 WITH TERMINAL 964328.
- 8 USE ITEM 261 WITH TERMINAL 1241406/2208461/2333551.

***WARNING**
ON INSTALLATION, SET WIRE DISC TO CRIMP HEIGHT REFERENCE SETTING FOR LARGEST WIRE SIZE. CRIMP HEIGHT REFERENCE SETTINGS GREATER THAN THE VALUE SHOWN MAY CAUSE DAMAGE TO THE CRIMP TOOLING. REFER TO THE INSTRUCTION SHEET FOR PROPER SETUP AND ADJUSTMENTS

9 THIS CRIMP PARAMETER IS PROVIDED TO MEET A CUSTOM AND UNIQUE CUSTOMER REQUIREMENT. IT HAS BEEN EVALUATED AND IS CONDITIONALLY SPECIFIED BY TE CONNECTIVITY. THIS CUSTOMIZED CRIMP PARAMETER IS NOT LISED AS AN APPROVED APPLICATION WITHIN A TE CONNECTIVITY APPLICATION SPECIFICATION. HOWEVER, IT HAS BEEN VALIEDTED ACCORDING TO TE CONNECTIVITY SPECIFICATIONS 109-18079 (TEST GROUP 1) AND 114-18022. **TE CONNECTIVITY EXPRESSLY DISCLAIMS ANY AND ALL WARRANTIES THAT THE PRODUCT WILL PERFORM SIMILARLY TO VALIDATED AND APPROVED APPLICATIONS, AS STATED WITHIN TE CONNECTIVITY APPLICATION SPECIFICATIONS, INCLUDING BUT NOT LIMITED TO IMPLIED WARRANTIES OF MERCHANTABILITY OR FITNESS FOR PARTICULAR PURPOSE.** AS SUCH, IT IS HIGHLY RECOMMENDED THAT THE CUSTOMER PERFORM FURTHER DETAILED EVALUATION TO ASSESS PRODUCT PERFORMANCE IN THE SPECIFIC APPLICATION.

10 THIS SPECIFICATIN PROVIDES AN ALTERNATE CRIMP HEIGHT FOR THE 4.00mm2.

LOC	DIST	REVISIONS					
A	66	P	LTN	DESCRIPTION	DATE	DWN	APVD
		K3		ECR-23-171761	10APR2023	FZ	GB
		K4		ECR-23-174134	03MAY2023	JWC	CB
		K5		ECR-23-193374	23NOV2023	FZ	JAH
		K6		ECR-24-212742	24JUN2024	ROY	TLE

	-	1	1	1-1752356-5	SUPPORT, TERMINAL	261
	-	1	-	2119641-1	FEED CAM, AIR FEED	248
	-	1	1	2119082-7	CAM, SNAIL, INSULATION ADJUSTMENT	244
	-	1	1	2079764-1	WASHER, WAVE SPRING, CREST-TO-CREST	243
	-	1	1	2119083-1	RETAINER, INSULATION DIAL	242
	-	1	1	18023-1	SCR, SKT HD CAP M3 X 5.0	241
	-	-	1	2119580-1	MECHANICAL FEED ASSEMBLY	239
	-	1	-	2844940-1	AIR FEED MODULE	238
	-	REF	REF	994970-2	COUNTER, MAGNETIC	164
	-	1	1	2119955-1	ASSY, LUBRICATOR, SIDE FEED	113
	-	1	1	2844908-1	SCREW, LOCKING	99
	-	1	1	2844907-1	POST, LOCKING	98
	-	1	1	455888-5	SPACER, CRIMPER -	82
	-	1	1	1803607-3	DOCUMENTATION PACKAGE	71
	-	1	1	2119791-9	DEPRESSOR, WIRE	70
	-	1	1	2119740-1	TAG IDENTIFICATION	67
	-	2	2	2168078-1	SCREW, DRIVE, RH, RoHS, 2 x .188	66
	-	1	1	2168083-2	SCR, SKT HD CAP, RoHS, M4 X 8.0	60
	-	1	1	5-18022-5	SCR, HEX HD CAP, M4 X 6.0	59
	-	1	1	1338685-1	PAWL, FEED	56
	-	4	4	2168083-3	SCR, SKT HD CAP, RoHS, M4 X 12.0	54
	-	2	2	1-2168083-0	SCR, SKT HD CAP, RoHS, M4 X 10	53
	-	1	1	1803382-2	HOLD DOWN, SPRING LOADED	50
	-	1	2	18023-9	SCR, SKT HD CAP M4 X 6.0	49
	-	-	1	2119652-1	FEED CAM, PRE FEED	48
	-	-	1	2119653-1	FEED CAM, POST FEED	47
	-	1	1	1803583-9	APPLICATOR BASIC ASSEMBLY, SF	46
	-	1	1	1803515-1	RAM ASSEMBLY, SF ATLANTIC	44
	-	1	1	1803602-1	SCR, BHSC, RoHS (M8 X 25)	41
	-	1	1	1-1752356-1	SUPPORT, TERMINAL	34
	-	2	2	2079383-5	SCR, BHSC, RoHS (M4 X 20)	33
	-	2	2	3-2844962-5	SPACER, CYLINDRICAL, STRIP GUIDE	30
	-	1	1	2844992-2	ASSEMBLY, STRIP GUIDE -	29
	-	1	1	1-455888-0	SPACER, CRIMPER -	28
	-	1	1	1320928-2	STRIP GUIDE -	24
	-	1	1	2168083-2	SCR, SKT HD CAP, RoHS, M4 X 8.0	21
	-	2	2	1-18028-2	WASHER, FLAT, REG M4	20
	-	1	1	2119533-1	STRIPPER, SIDE FEED	19
	-	1	1	2119806-1	INSERT, SHEAR	13
	-	1	1	3-22280-3	SPRING, COMPRESSION	12
	-	1	1	1-356885-4	STOP, SHEAR	11
	-	1	1	2119805-1	SHEAR HOLDER, FRONT -	10
	-	1	1	454276-5	FLOATING SHEAR, FRONT	9
	1	1	1	1333209-1	ANVIL, COMBINATION .130	8
	-	1	1	1-2119757-0	DEPRESSOR, SHEAR	5
	-	1	1	1-238011-7	BLOCK, CRIMPER SPACER	4
	1	1	1	2119785-3	CRIMPER, INSULATION OVERLAP PREMIUM	3
	1	1	1	456410-4	CRIMPER, WIRE PREMIUM	1

DIMENSIONS:		TOLERANCES UNLESS OTHERWISE SPECIFIED:		MATERIAL:		FINISH:	
mm	0 PLC ±	1 PLC ±	2 PLC ±	3 PLC ±	4 PLC ±	ANGLES ±	FINISH

CHK	DATE	NAME	DESCRIPTION	ITEM NO
H. HUANG	16SEP2011			
S. XI	16SEP2011			
J. CRUZ	16SEP2011			

SIZE	CAGE CODE	DRAWING NO	RESTRICTED TO
A1	00779	2151070	-

Customer Accessible Production Drawing SCALE 1:2 SHEET 1 OF 4 REV K6

LOC	DIST	REVISIONS					
		P	LTN	DESCRIPTION	DATE	OWN	APVD
A	66	-	-	SEE SHEET 1	-	-	-

FEED TYPE MECHANICAL

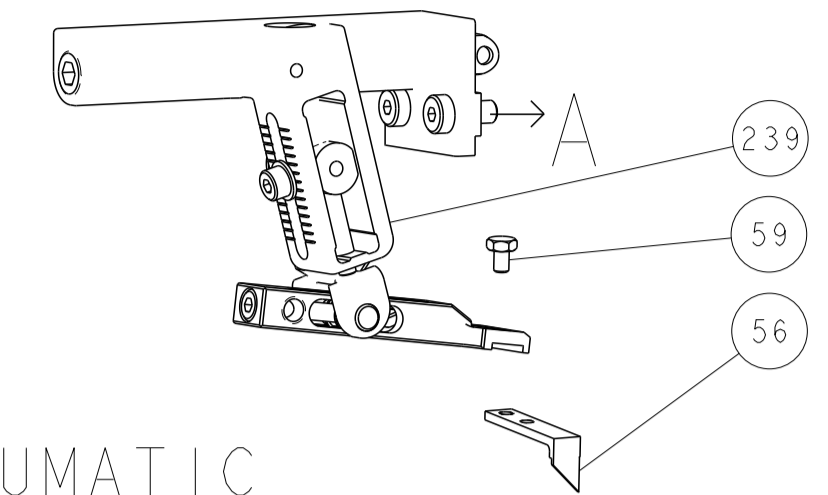

PNEUMATIC

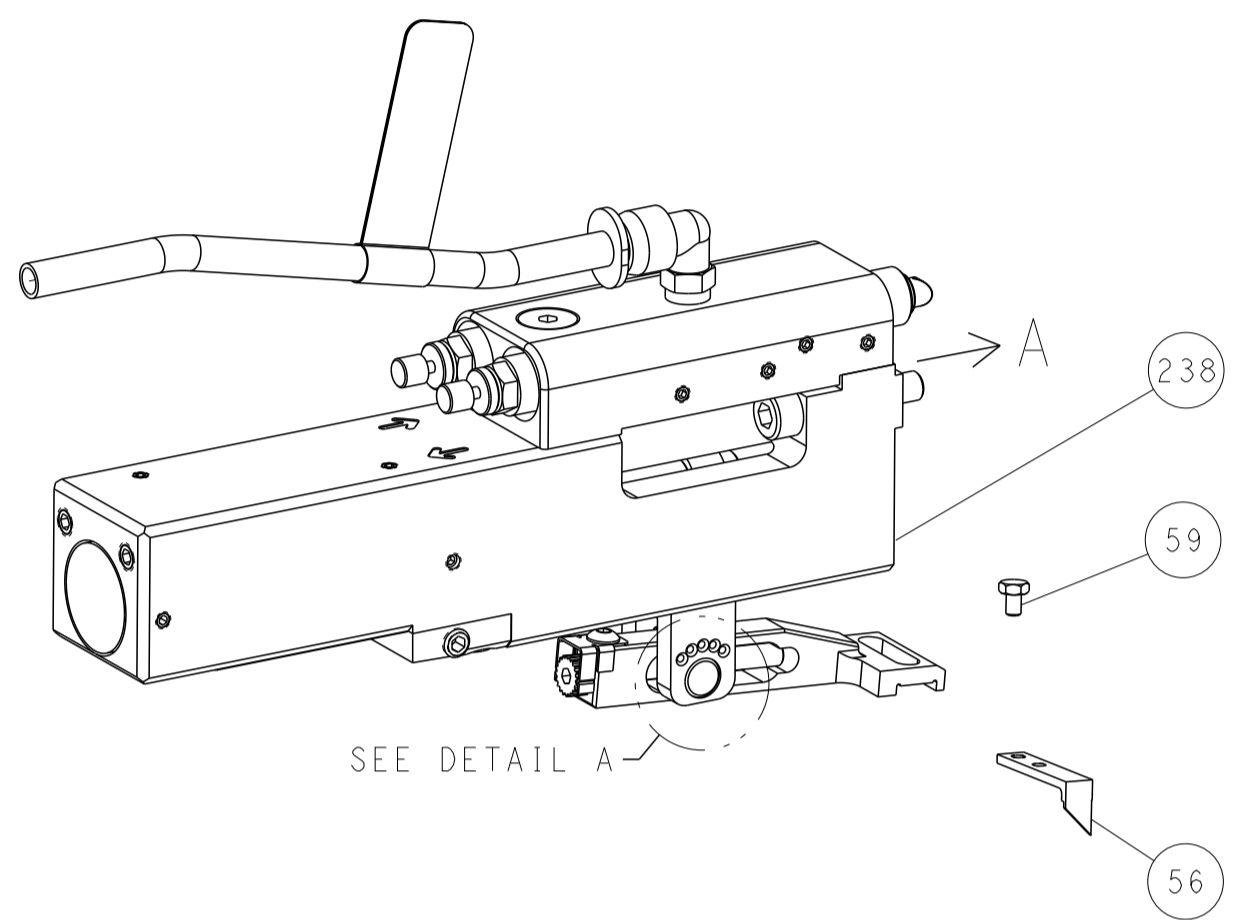

FEED SPRING SETTING POSITION (SHOWN FROM REAR SIDE)



DETAIL A

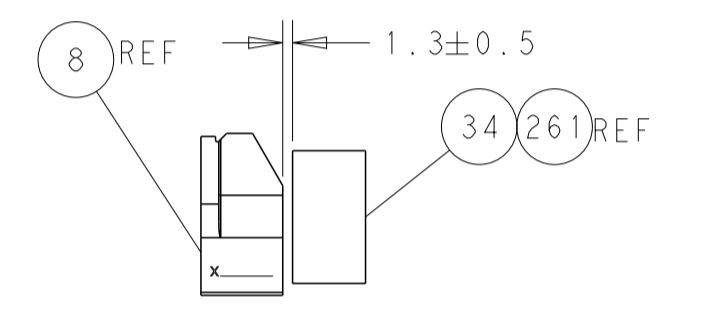
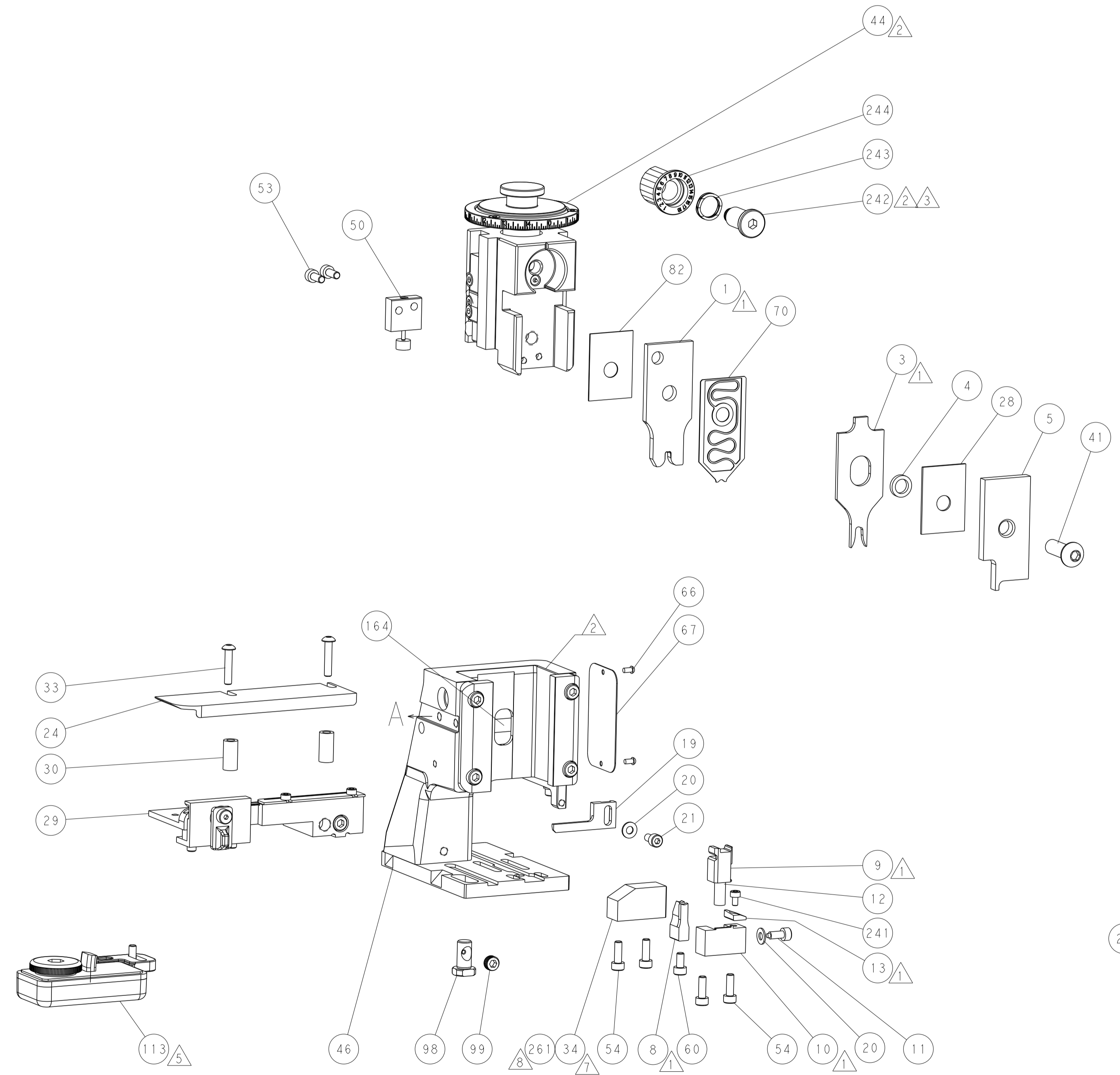

TERMINAL SUPPORT LOCATION

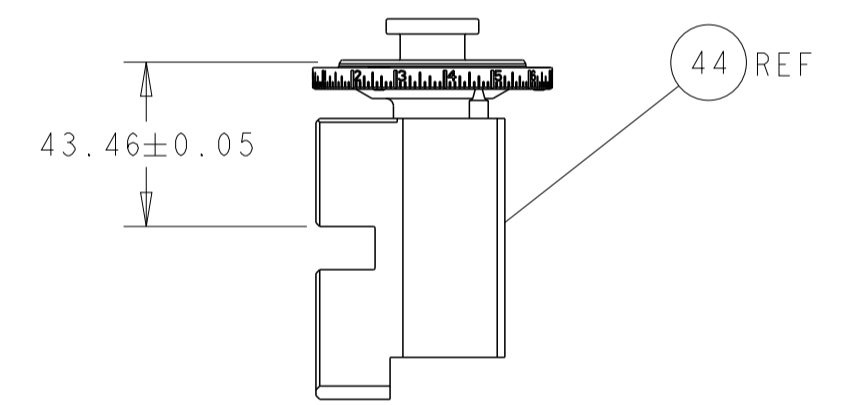

RAM SET-UP

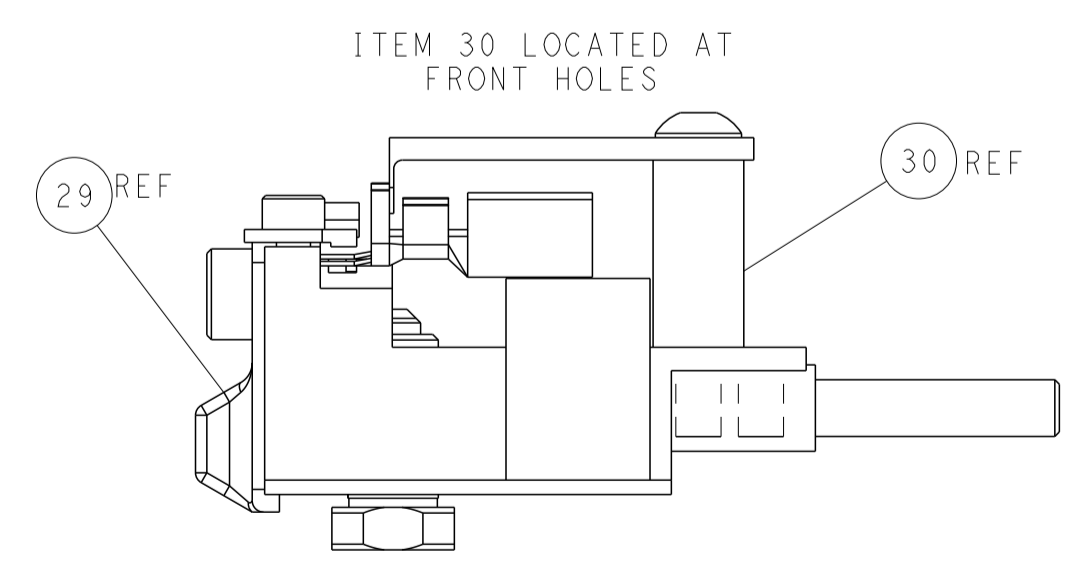

FEED TRACK POSITION GUIDE BY INSULATION BARREL

CAM POSITIONS

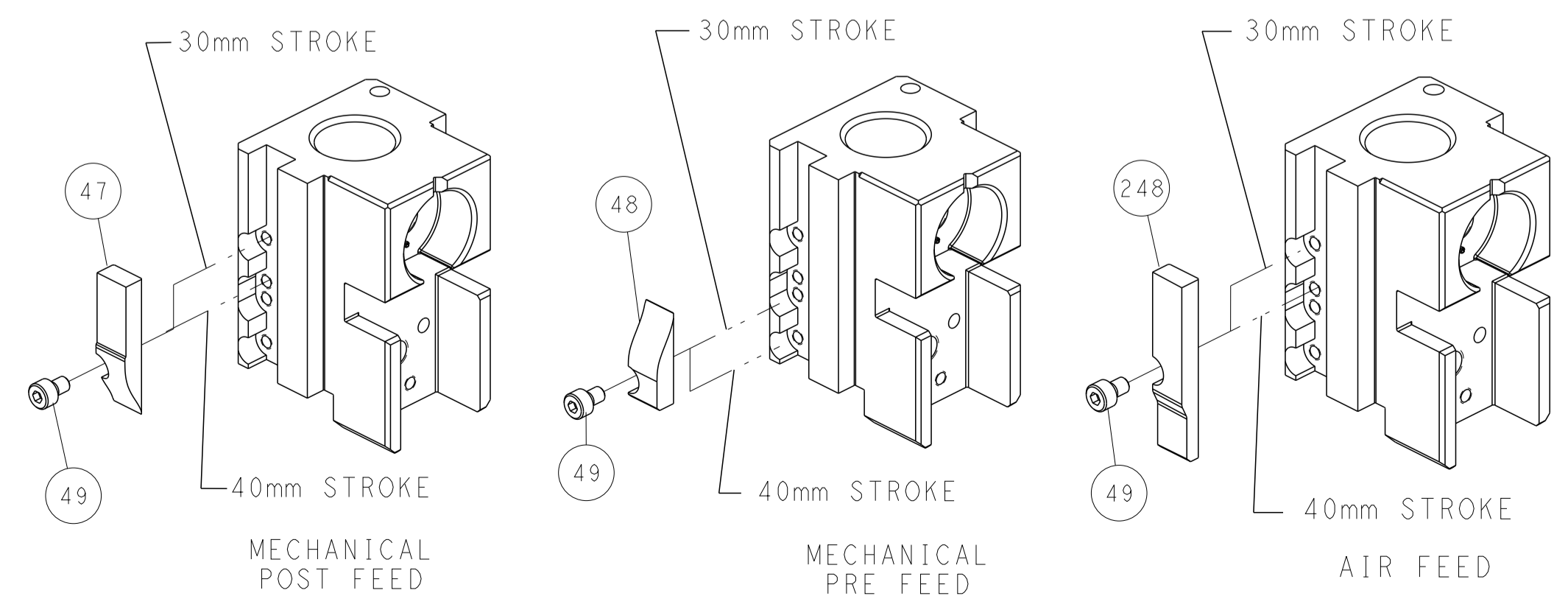

DIMENSIONS: mm 		TOLERANCES UNLESS OTHERWISE SPECIFIED: 0 PLC ± 1 PLC ± 2 PLC ± 3 PLC ± 4 PLC ± ANGLES ± FINISH		DWN R. HUANG 16SEP2011 CHK S. XI 16SEP2011 APVD J. CRUZ 01JUN2011 PRODUCT SPEC APPLICATION SPEC WEIGHT MATERIAL		NAME Ocean Side Feed Applicator SIZE CAGE CODE DRAWING NO A1 00779 C=2151070 RESTRICTED TO	
Customer Accessible Production Drawing		SCALE 1:2		SHEET 2 OF 4		REV K6	