

PART NUMBER	REVISION	DESCRIPTION	FEED TYPE
2151581-1	E	FINE CRIMP HEIGHT ADJUST	MECHANICAL
2151581-2	E	FINE CRIMP HEIGHT ADJUST	PNEUMATIC
7-2151581-1	E	MECHANICAL AND CRIMP TOOLING KIT	MECHANICAL
7-2151581-2	E	PNEUMATIC AND CRIMP TOOLING KIT	PNEUMATIC
7-2151581-7	A	CRIMP TOOLING KIT	-

ATLANTIC VERSION TERMINATOR INTERFACE ADAPTER



APPLICATOR DATA		
CRIMP	SIZE	TYPE
WIRE	1.78 mm [.070]	F
INSUL	2.29 mm [.090]	OV

APPLICATOR INSTRUCTIONS
408-35042

TERMINAL DATA: TE TERMINAL		TE CRIMP SPECIFICATION	
TERMINAL NAME: AMP MCP 1.5K DOUBLE CRIMP			
WIRE STRIP LENGTH		INSULATION DIAMETER RANGE	
3.90-4.50 mm [.154-.177 IN]		∅2 X 1.60mm MAX [2 X .063 IN MAX]	
TERMINAL APPLICATION SPECIFICATION	114-18386		
TERMINALS APPLIED			
TE TERMINAL	TE TERMINAL	TE TERMINAL	TE TERMINAL
1241376-1			

WIRE SIZE	CRIMP HEIGHT mm [INCH]	CRIMP HEIGHT REFERENCE SETTING
1.00mm2	1.26 +/- 0.05 [.050 +/- .002]	4.5
0.85mm2	1.19 +/- 0.05 [.047 +/- .002]	5.2
0.70mm2	1.13 +/- 0.05 [.044 +/- .002]	5.8
0.50mm2	1.04 +/- 0.05 [.041 +/- .002]	6.6

- RECOMMENDED SPARE PARTS
- REFER TO SUPPLIED INSTRUCTION SHEET FOR CLEANING, LUBRICATION AND STORAGE OF APPLICATOR.
- APPLY PART NUMBER 2-23419-6 LOCTITE TO THREADS OF ITEM 242.
- CRIMP HEIGHT REFERENCE SETTING WAS THE SETTING USED WHEN THE APPLICATOR WAS QUALIFIED AT THE FACTORY. ADJUSTMENT MAY BE NECESSARY WHEN RUNNING APPLICATOR IN THE FIELD.
- 5. UNLESS SPECIFIED OTHERWISE TORQUE VALUES SHALL BE USED PER DOCUMENT, 101-35000.
- THIS APPLICATOR APPLIES A DOUBLE WIRE COMBINATION FOR THE SPECIFIED WIRE SIZES.
- TERMINAL LUBRICANT IS RECOMMENDED.

***WARNING**
ON INSTALLATION, SET WIRE DISC TO CRIMP HEIGHT REFERENCE SETTING FOR LARGEST WIRE SIZE. CRIMP HEIGHT REFERENCE SETTINGS GREATER THAN THE VALUE SHOWN MAY CAUSE DAMAGE TO THE CRIMP TOOLING, REFER TO THE INSTRUCTION SHEET FOR PROPER SETUP AND ADJUSTMENTS.

LOC	DIST	REVISIONS					
A	66	P	LTN	DESCRIPTION	DATE	OWN	APVD
		B		ECR-16-008402	09JUN2016	MEH	JDG
		C		ECR-16-012632	02SEP2016	KH	TE
		D		ECR-18-017057	30OCT2018	FL	TE
		E		ECR-23-187546	19SEP2023	JWC	TE

-	1	-	1	-	2119641-1	FEED CAM, AIR FEED	248	
-	1	1	1	1	2119082-9	CAM, SNAIL, INSULATION ADJUSTMENT	244	
-	1	1	1	1	2079764-1	WASHER, WAVE SPRING, CREST-TO-CREST	243	
-	1	1	1	1	2119083-1	RETAINER, INSULATION DIAL	242	
-	1	1	1	1	7-18023-7	SCR, SKT HD CAP M3 X 4.0	241	
-	-	1	-	1	2119580-1	MECHANICAL FEED ASSEMBLY	239	
-	1	-	1	-	2844940-1	AIR FEED MODULE	238	
-	REF	REF	REF	REF	994970-2	COUNTER, MAGNETIC	164	
-	1	1	1	1	2119955-1	ASSY, LUBRICATOR, SIDE FEED	113	
-	1	1	1	1	2844908-1	SCREW, LOCKING	99	
-	1	1	1	1	2844907-1	POST, LOCKING	98	
-	1	1	1	1	455888-4	SPACER, CRIMPER	82	
-	1	1	1	1	1803607-3	DOCUMENTATION PACKAGE	71	
-	1	1	1	1	2119791-9	DEPRESSOR, WIRE	70	
-	1	1	1	1	2119943-1	WASHER, SPACER	69	
-	1	1	1	1	2119740-1	TAG, IDENTIFICATION	67	
-	2	2	2	2	2168078-1	SCREW, DRIVE, RH, RoHS, 2 x .188	66	
-	1	1	1	1	2168083-2	SCR, SKT HD CAP, RoHS, M4 X 8.0	60	
-	1	1	1	1	5-18022-5	SCR, HEX HD CAP, M4 X 6.0	59	
-	1	1	1	1	1338685-1	PAWL, FEED	56	
-	4	4	4	4	2168083-3	SCR, SKT HD CAP, RoHS, M4 X 12.0	54	
-	2	2	2	2	1-2168083-0	SCR, SKT HD CAP, RoHS, M4 X 10	53	
-	1	1	1	1	1803382-6	HOLD DOWN, SPRING LOADED	50	
-	1	2	1	2	18023-9	SCR, SKT HD CAP M4 X 6.0	49	
-	-	1	-	1	2119652-1	FEED CAM, PRE FEED	48	
-	-	1	-	1	2119653-1	FEED CAM, POST FEED	47	
-	1	1	1	1	1803583-9	APPLICATOR BASIC ASSEMBLY, SF	46	
-	1	1	1	1	1803515-1	RAM ASSEMBLY, SF ATLANTIC	44	
-	1	1	1	1	1803602-1	SCR, BHSC, RoHS (M8 X 25)	41	
-	1	1	1	1	1-1752356-7	SUPPORT, TERMINAL	34	
-	2	2	2	2	2079383-5	SCR, BHSC, RoHS (M4 X 20)	33	
-	2	2	2	2	3-2844962-0	SPACER, CYLINDRICAL, STRIP GUIDE	30	
-	1	1	1	1	2844992-2	ASSEMBLY, STRIP GUIDE	29	
-	1	1	1	1	1-455888-0	SPACER, CRIMPER	28	
-	1	1	1	1	1320928-2	STRIP GUIDE	24	
-	1	1	1	1	2168083-2	SCR, SKT HD CAP, RoHS, M4 X 8.0	21	
-	2	2	2	2	1-18028-2	WASHER, FLAT, REG M4	20	
-	1	1	1	1	2119533-1	STRIPPER, SIDE FEED	19	
-	1	1	1	1	2119806-1	INSERT, SHEAR	13	
-	1	1	1	1	3-22280-3	SPRING, COMPRESSION	12	
-	1	1	1	1	1-356885-4	STOP, SHEAR	11	
-	1	1	1	1	2119805-1	SHEAR HOLDER, FRONT	10	
-	1	1	1	1	454276-5	FLOATING SHEAR, FRONT	9	
-	1	2	2	1	1	6-1333203-1	ANVIL, COMBINATION	8
-	-	-	-	-	-	-	7	
-	-	-	-	-	-	-	6	
-	1	1	1	1	2119757-8	DEPRESSOR, SHEAR	5	
-	1	1	1	1	2-238011-2	BLOCK, CRIMPER SPACER	4	
-	1	2	2	1	1	3-2119785-0	CRIMPER, INSULATION OVERLAP PREMIUM	3
-	1	1	1	1	455888-7	SPACER, CRIMPER	2	
-	1	2	2	1	1	3-456404-5	CRIMPER, WIRE PREMIUM	1
-	77	-72	-71	-2	-1	PART NO	DESCRIPTION	ITEM NO

ATLANTIC VERSION
Shown on sheets 1 of 4 & 2 of 4
(Pacific version shown on sheets 3 of 4 & 4 of 4)

DIMENSIONS:		TOLERANCES UNLESS OTHERWISE SPECIFIED:		OWN: H. STAKEM 22OCT2012		TE Connectivity Harrisburg, PA 17105-3608	
mm		0 PLC ±		CHK: T. ELBIN 22OCT2012		NAME: Ocean Side Feed Applicator	
		1 PLC ±		APVD: T. ELBIN 22OCT2012		SIZE: A1	
		2 PLC ±		PRODUCT SPEC		CAGE CODE: 00779	
		3 PLC ±		APPLICATION SPEC		DRAWING NO: 2151581	
		4 PLC ±		WEIGHT		SCALE: 1:2	
		ANGLES		CUSTOMER ACCESSIBLE PRODUCTION DRAWING		SHEET 1 OF 4	
		FINISH		REVISIONS		REV E	

LOC	DIST	REV	DATE	BY	CHKD	APVD
A	66					

FEED TYPE MECHANICAL

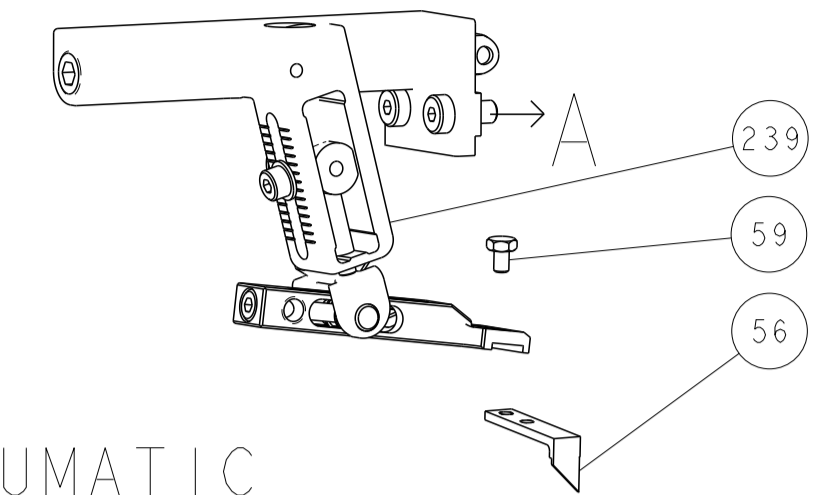

PNEUMATIC

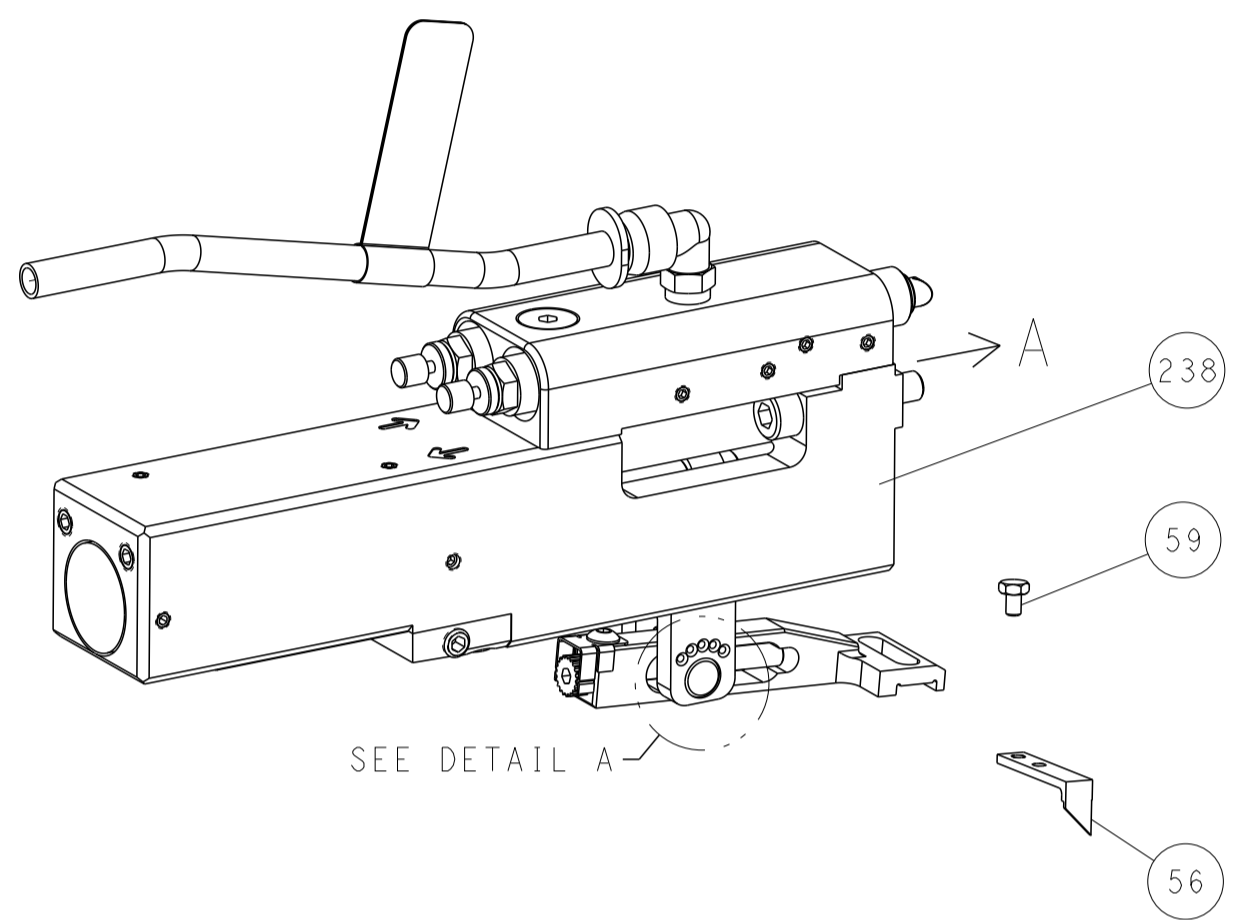

FEED SPRING SETTING POSITION (SHOWN FROM REAR SIDE)



DETAIL A

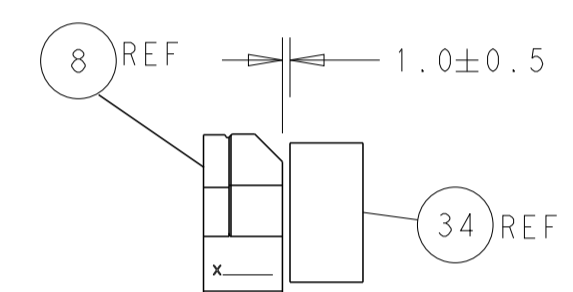
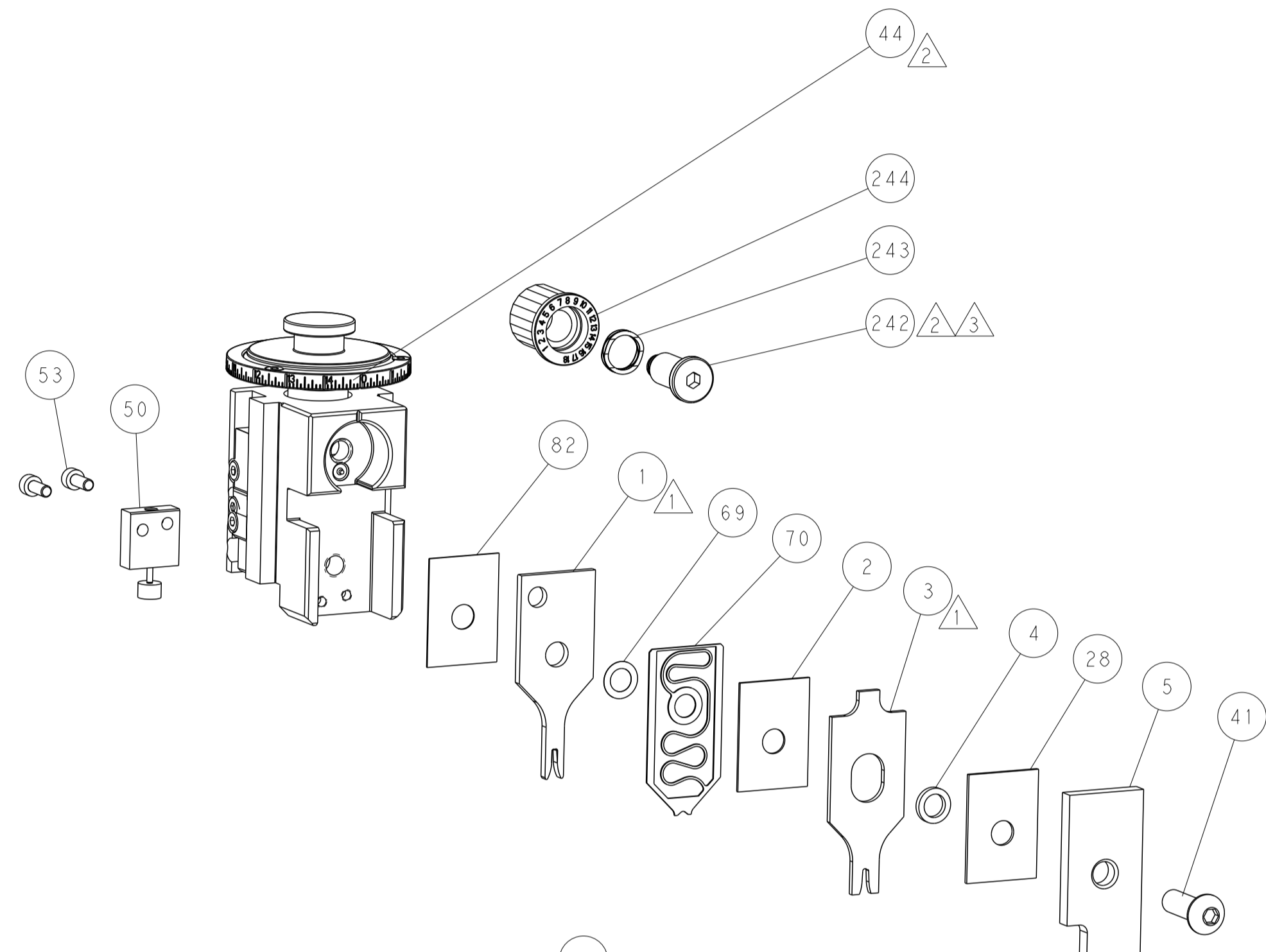

TERMINAL SUPPORT LOCATION

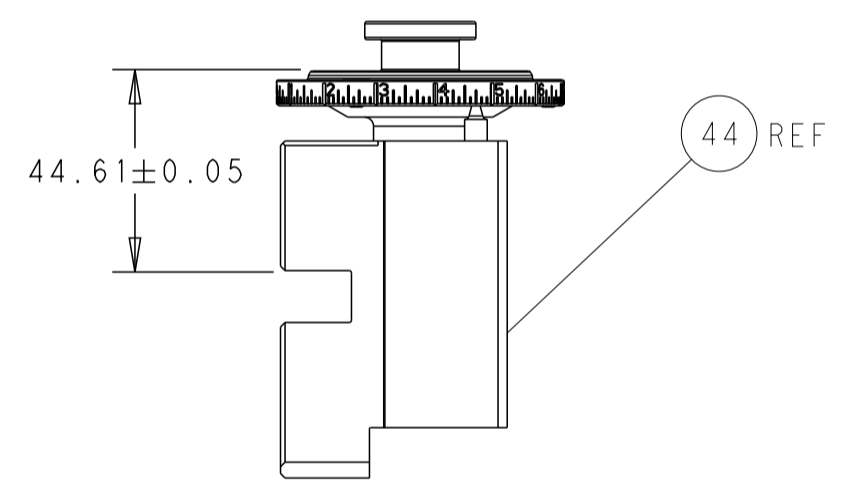

RAM SET-UP

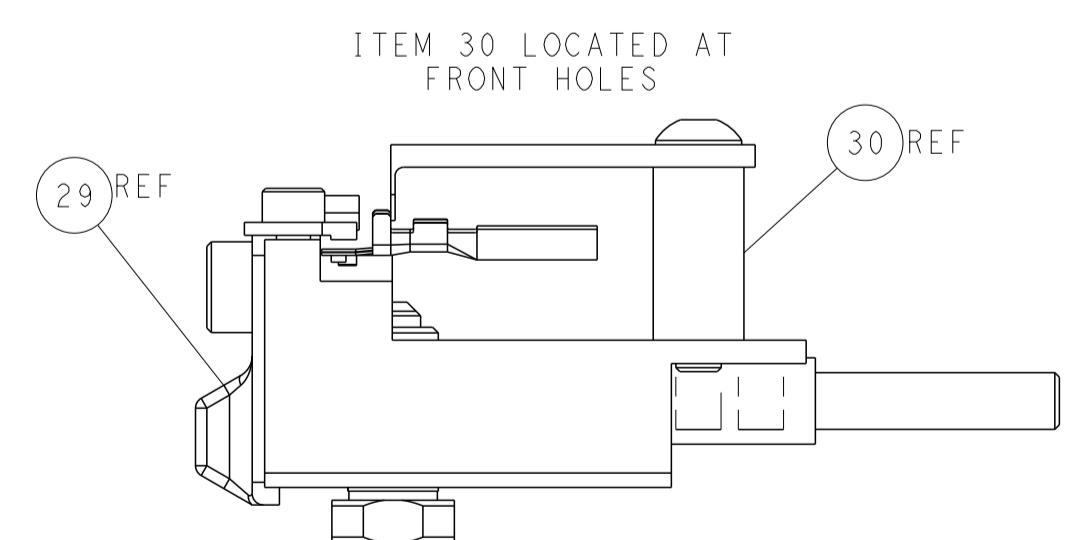
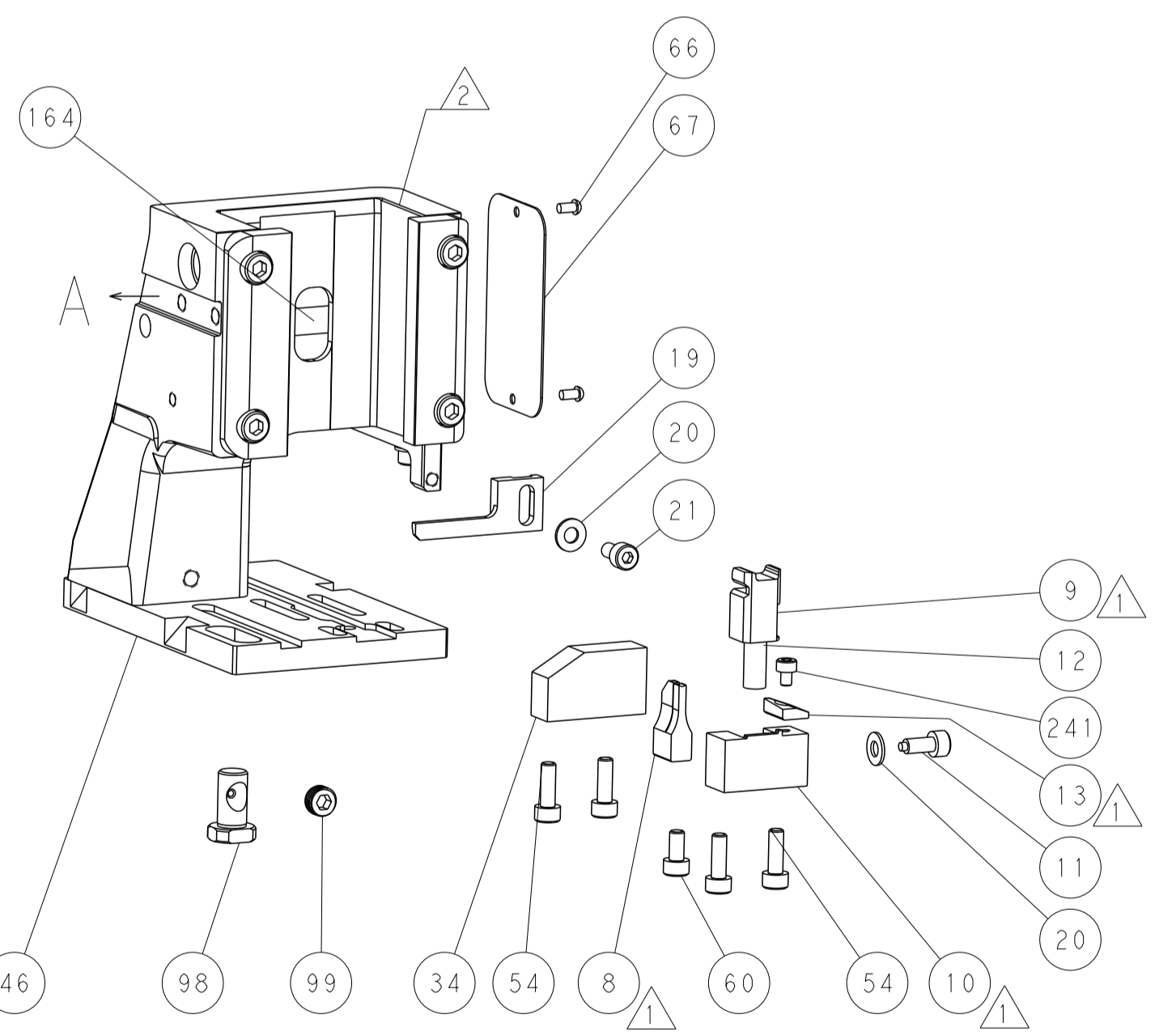
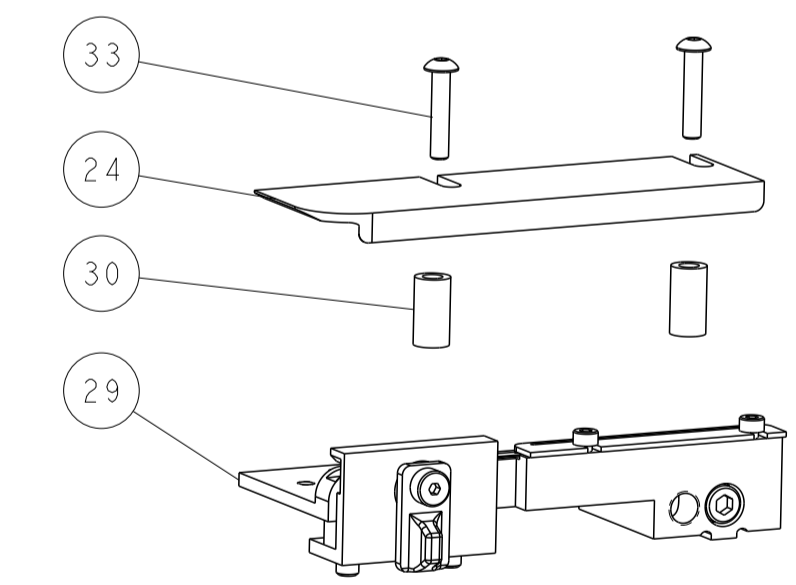

FEED TRACK POSITION GUIDE BY INSULATION BARREL

CAM POSITIONS

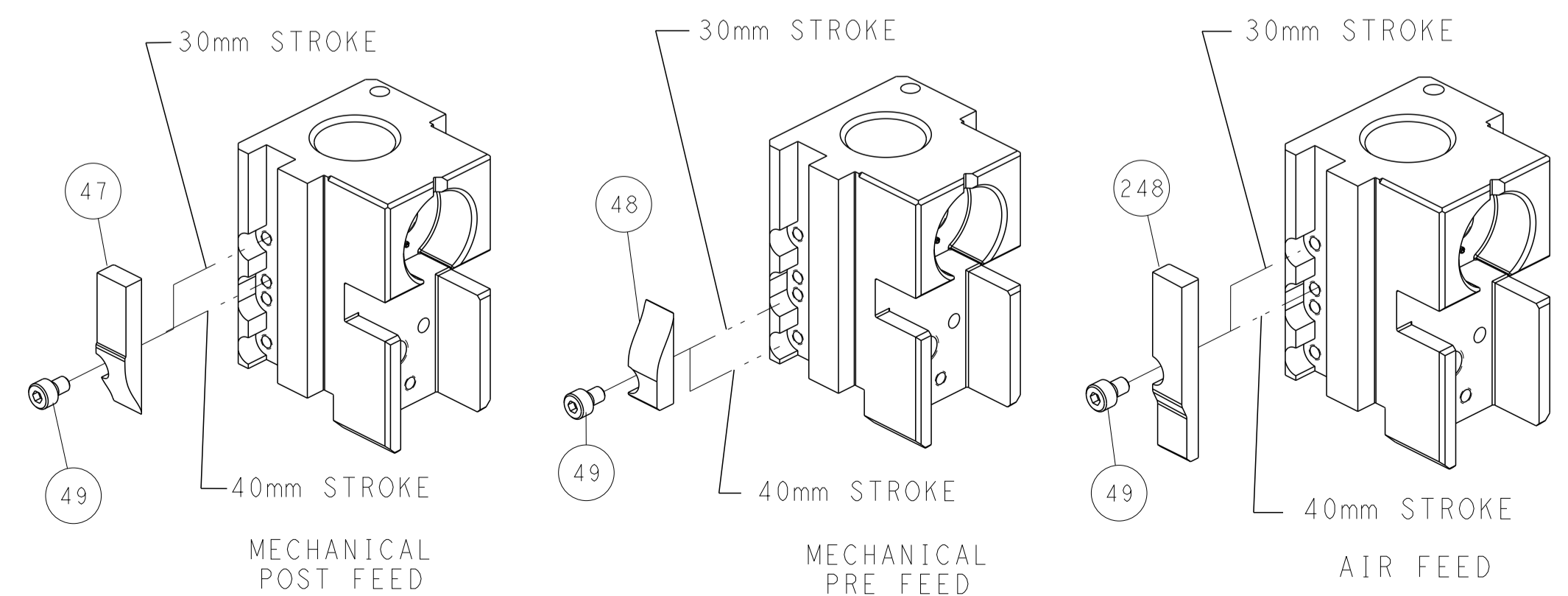

ATLANTIC VERSION
 Shown on sheets 1 of 4 & 2 of 4
 (Pacific version shown on sheets 3 of 4 & 4 of 4)

DIMENSIONS:		TOLERANCES UNLESS OTHERWISE SPECIFIED:		DWG: H. STAKEM 22OCT2012		TE Connectivity	
mm		0 PLC ±		CHK: T. ELBIN 22OCT2012		Harrisburg, PA 17105-3608	
Ø		1 PLC ±		APVD: T. ELBIN 22OCT2012		NAME: Ocean Side Feed Applicator	
H		2 PLC ±		PRODUCT SPEC		SIZE: CAGE CODE: DRAWING NO: RESTRICTED TO	
D		3 PLC ±		APPLICATION SPEC		A1 00779 ©=2151581	
R		4 PLC ±		WEIGHT		CUSTOMER ACCESSIBLE PRODUCTION DRAWING	
ANGLES		FINISH		SCALE: 1:2		SHEET 2 OF 4 REV E	

PART NUMBER	REVISION	DESCRIPTION	FEED TYPE
2-2151581-1	E	FINE CRIMP HEIGHT ADJUST	MECHANICAL
2-2151581-2	E	FINE CRIMP HEIGHT ADJUST	PNEUMATIC
7-2151581-7	A	CRIMP TOOLING KIT	-

PACIFIC VERSION TERMINATOR
INTERFACE ADAPTER



APPLICATOR DATA		
CRIMP	SIZE	TYPE
WIRE	1.78 mm [.070]	F
INSUL	2.29 mm [.090]	OV
APPLICATOR INSTRUCTIONS 408-35042		

TERMINAL DATA: TE TERMINAL		TE CRIMP SPECIFICATION	
TERMINAL NAME: AMP MCP 1.5K DOUBLE CRIMP			
WIRE STRIP LENGTH		INSULATION DIAMETER RANGE	
3.90-4.50 mm [1.54-.177 IN]		Ø2 X 1.60mm MAX [2 X .063 IN MAX]	
TERMINAL APPLICATION SPECIFICATION		114-18386	
TERMINALS APPLIED			
TE TERMINAL	TE TERMINAL	TE TERMINAL	TE TERMINAL
1241376-1			

WIRE SIZE	CRIMP HEIGHT mm [INCH]	CRIMP HEIGHT REFERENCE SETTING
1.00mm2	1.26 +/- 0.05 [0.050 +/- .002]	4.5
0.85mm2	1.19 +/- 0.05 [0.047 +/- .002]	5.2
0.70mm2	1.13 +/- 0.05 [0.044 +/- .002]	5.8
0.50mm2	1.04 +/- 0.05 [0.041 +/- .002]	6.6

- RECOMMENDED SPARE PARTS
- REFER TO SUPPLIED INSTRUCTION SHEET FOR CLEANING, LUBRICATION AND STORAGE OF APPLICATOR.
- APPLY PART NUMBER 2-23419-6 LOCTITE TO THREADS OF ITEM 242.
- CRIMP HEIGHT REFERENCE SETTING WAS THE SETTING USED WHEN THE APPLICATOR WAS QUALIFIED AT THE FACTORY. ADJUSTMENT MAY BE NECESSARY WHEN RUNNING APPLICATOR IN THE FIELD.
- UNLESS SPECIFIED OTHERWISE TORQUE VALUES SHALL BE USED PER DOCUMENT, 101-35000.
- THIS APPLICATOR APPLIES A DOUBLE WIRE COMBINATION FOR THE SPECIFIED WIRE SIZES.
- TERMINAL LUBRICANT IS RECOMMENDED.

***WARNING**
ON INSTALLATION, SET WIRE DISC TO CRIMP HEIGHT REFERENCE SETTING FOR LARGEST WIRE SIZE. CRIMP HEIGHT REFERENCE SETTINGS GREATER THAN THE VALUE SHOWN MAY CAUSE DAMAGE TO THE CRIMP TOOLING, REFER TO THE INSTRUCTION SHEET FOR PROPER SETUP AND ADJUSTMENTS.

LOC	DIST	REVISIONS					
A	66	P	LTN	DESCRIPTION	DATE	OWN	APVD
		-		SEE SHEET 1			

-	1	1	2119082-9	CAM, SNAIL, INSULATION ADJUSTMENT	244
-	1	1	2079764-1	WASHER, WAVE SPRING, CREST-TO-CREST	243
-	1	1	2119083-1	RETAINER, INSULATION DIAL	242
-	1	1	7-18023-7	SCR, SKT HD CAP M3 X 4.0	241
-	-	1	2119580-1	MECHANICAL FEED ASSEMBLY	239
-	1	-	2844940-1	AIR FEED MODULE	238
-	REF	REF	994970-2	COUNTER, MAGNETIC	164
-	1	-	2119641-2	FEED CAM, AIR FEED	151
-	1	1	2168083-8	SCR, SKT HD CAP, RoHS, M4 X 16	144
-	4	4	2168083-9	SCR, SKT HD CAP, RoHS, M4 X 20	143
-	-	1	2119653-2	FEED CAM, POST FEED	142
-	1	1	1-1803583-0	APPLICATOR BASIC ASSEMBLY, SF	141
-	1	1	1803516-1	RAM ASSEMBLY, SF PACIFIC	140
-	1	1	2119955-1	ASSY, LUBRICATOR, SIDE FEED	113
-	1	1	2844908-1	SCREW, LOCKING	99
-	1	1	2844907-1	POST, LOCKING	98
-	1	1	455888-4	SPACER, CRIMPER	82
-	1	1	1803607-3	DOCUMENTATION PACKAGE	71
-	1	1	2119791-9	DEPRESSOR, WIRE	70
-	1	1	2119943-1	WASHER, SPACER	69
-	1	1	2119740-1	TAG IDENTIFICATION	67
-	2	2	2168078-1	SCREW, DRIVE, RH, RoHS, 2 x .188	66
-	1	1	5-18022-5	SCR, HEX HD CAP, M4 X 6.0	59
-	1	1	1338685-1	PAWL, FEED	56
-	2	2	1-2168083-0	SCR, SKT HD CAP, RoHS, M4 X 10	53
-	1	1	1803382-6	HOLD DOWN, SPRING LOADED	50
-	1	2	18023-9	SCR, SKT HD CAP M4 X 6.0	49
-	-	1	2119652-1	FEED CAM, PRE FEED	48
-	1	1	1803602-1	SCR, BHSC, RoHS (M8 X 25)	41
-	1	1	1-1752356-7	SUPPORT, TERMINAL	34
-	2	2	2079383-5	SCR, BHSC, RoHS (M4 X 20)	33
-	2	2	3-2844962-0	SPACER, CYLINDRICAL, STRIP GUIDE	30
-	1	1	2844992-2	ASSEMBLY, STRIP GUIDE	29
-	1	1	1-455888-0	SPACER, CRIMPER	28
-	1	1	1320928-2	STRIP GUIDE	24
-	1	1	2168083-2	SCR, SKT HD CAP, RoHS, M4 X 8.0	21
-	2	2	1-18028-2	WASHER, FLAT, REG M4	20
-	1	1	2119533-1	STRIPPER, SIDE FEED	19
-	1	1	2119806-1	INSERT, SHEAR	13
-	1	1	3-22280-3	SPRING, COMPRESSION	12
-	1	1	1-356885-4	STOP, SHEAR	11
-	1	1	2119805-1	SHEAR HOLDER, FRONT	10
-	1	1	454276-5	FLOATING SHEAR, FRONT	9
-	1	1	1-1333203-1	ANVIL, COMBINATION	8
-	-	-	-	-	7
-	-	-	-	-	6
-	1	1	2119757-8	DEPRESSOR, SHEAR	5
-	1	1	2-238011-2	BLOCK, CRIMPER SPACER	4
-	1	1	3-2119785-0	CRIMPER, INSULATION OVERLAP PREMIUM	3
-	1	1	455888-7	SPACER, CRIMPER	2
-	1	1	3-456404-5	CRIMPER, WIRE PREMIUM	1

PACIFIC VERSION
Shown on sheets 3 of 4 & 4 of 4
(Atlantic version shown on sheets 1 of 4 & 2 of 4)

DIMENSIONS:		TOLERANCES UNLESS OTHERWISE SPECIFIED:		DWG: H. STAKEM 22OCT2012		TE Connectivity Harrisburg, PA 17105-3608	
mm	0 PLC ±	1 PLC ±	2 PLC ±	3 PLC ±	4 PLC ±	NAME: Ocean Side Feed Applicator	
MATERIAL:		FINISH:		APVD: T. ELBIN 22OCT2012		SIZE: A1	
CUSTOMER ACCESSIBLE PRODUCTION DRAWING		SCALE: 1:2		SHEET: 3 OF 4		REV: E	

LOC		DIST		REVISIONS			
P	LTN	DESCRIPTION	DATE	DWN	APVD		
-	-	SEE SHEET 1	-	-	-		

FEED TYPE MECHANICAL

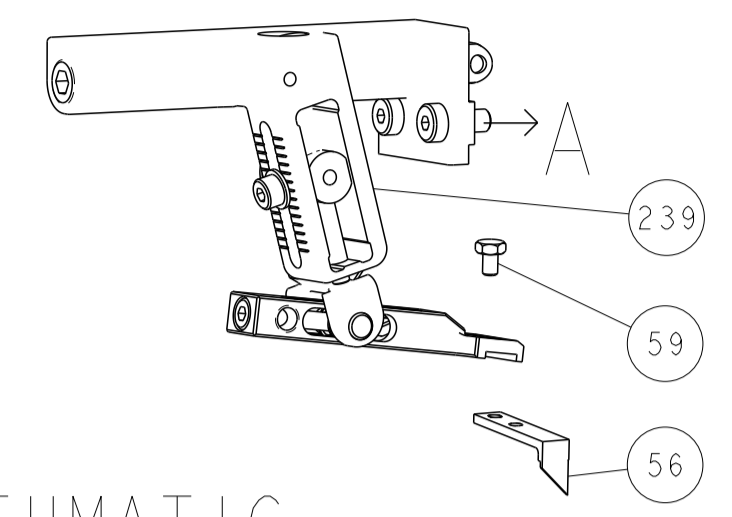

PNEUMATIC

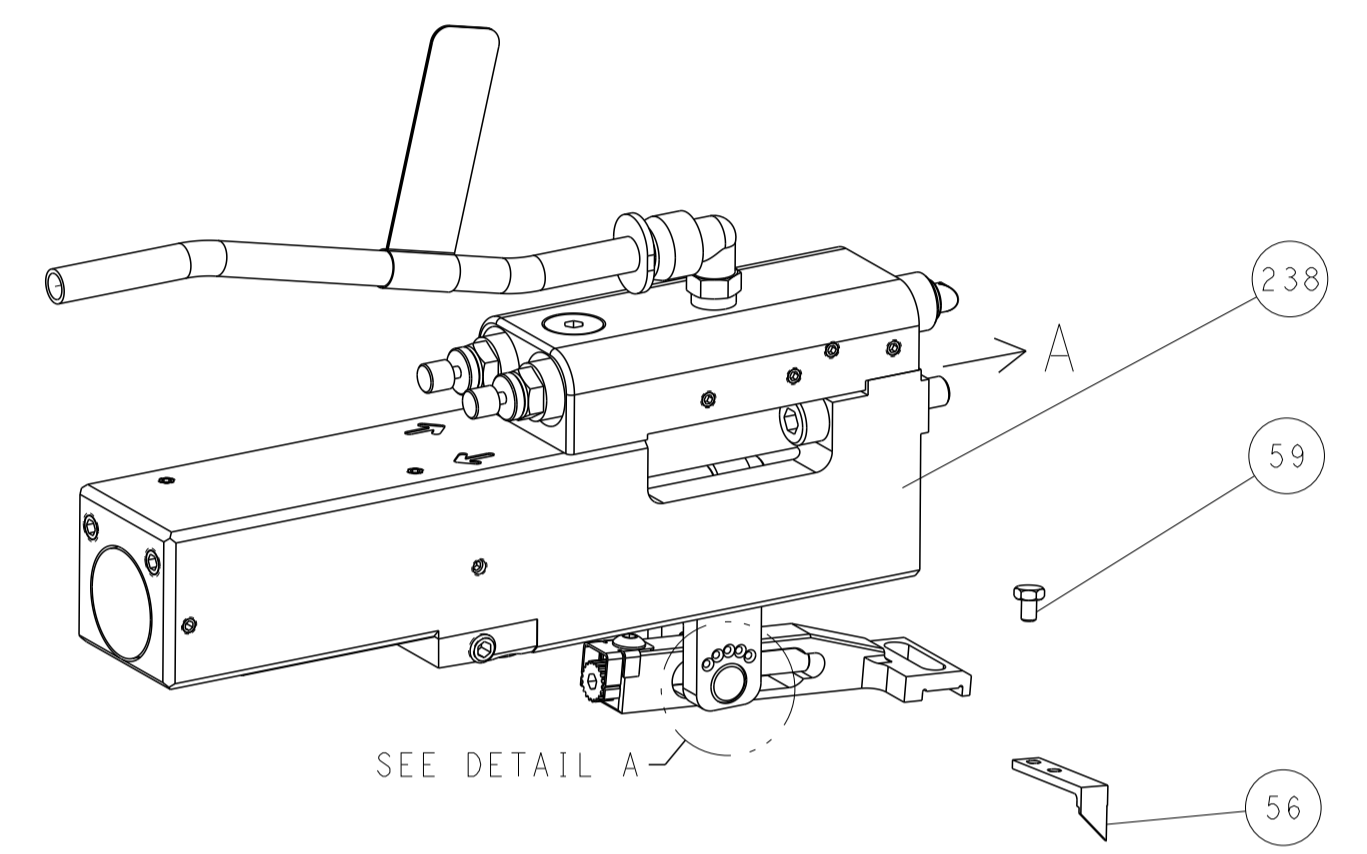

FEED SPRING SETTING POSITION (SHOWN FROM REAR SIDE)



CAM POSITIONS

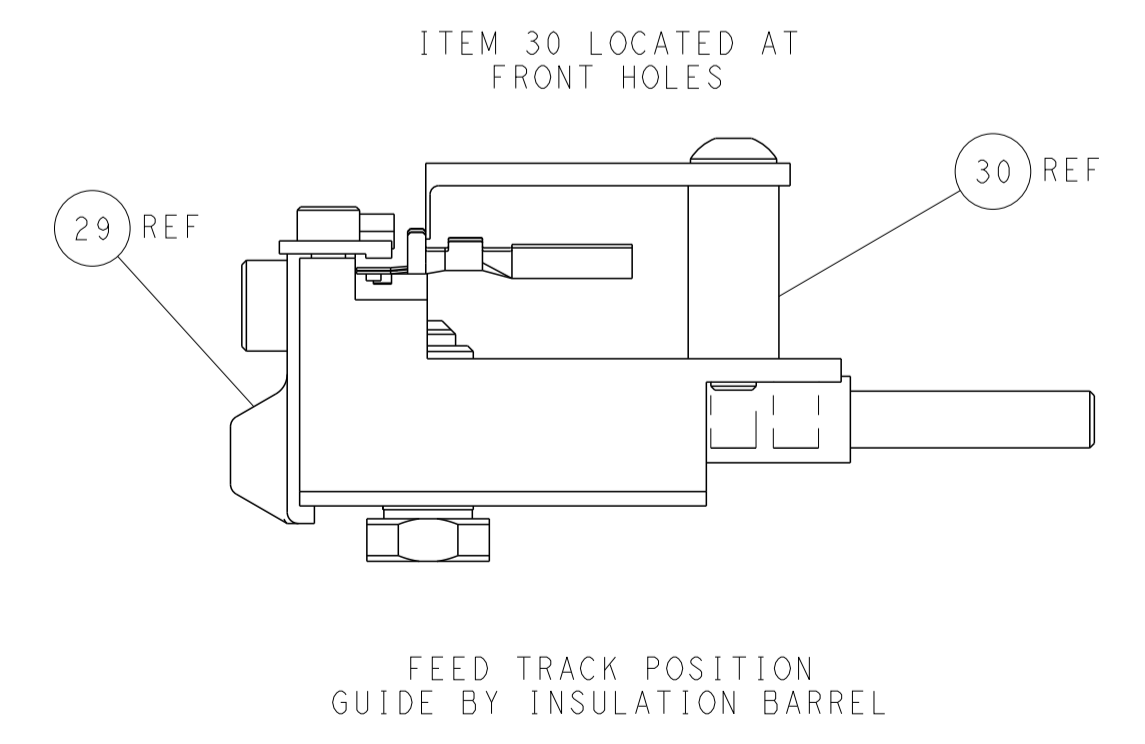
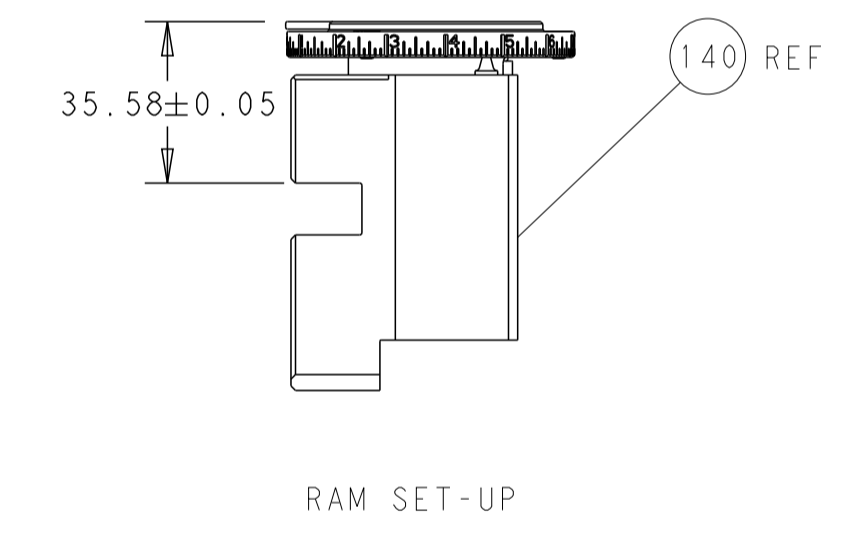
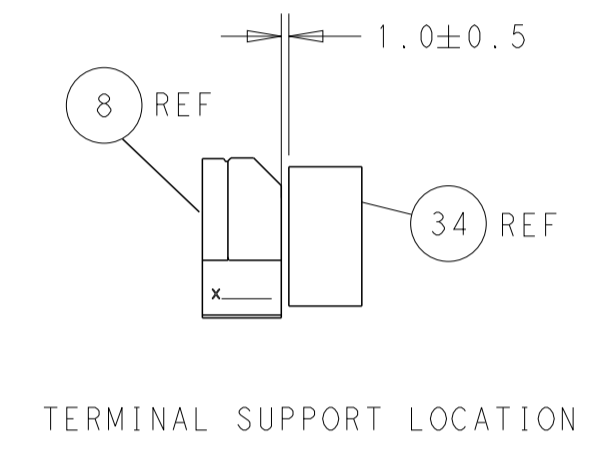
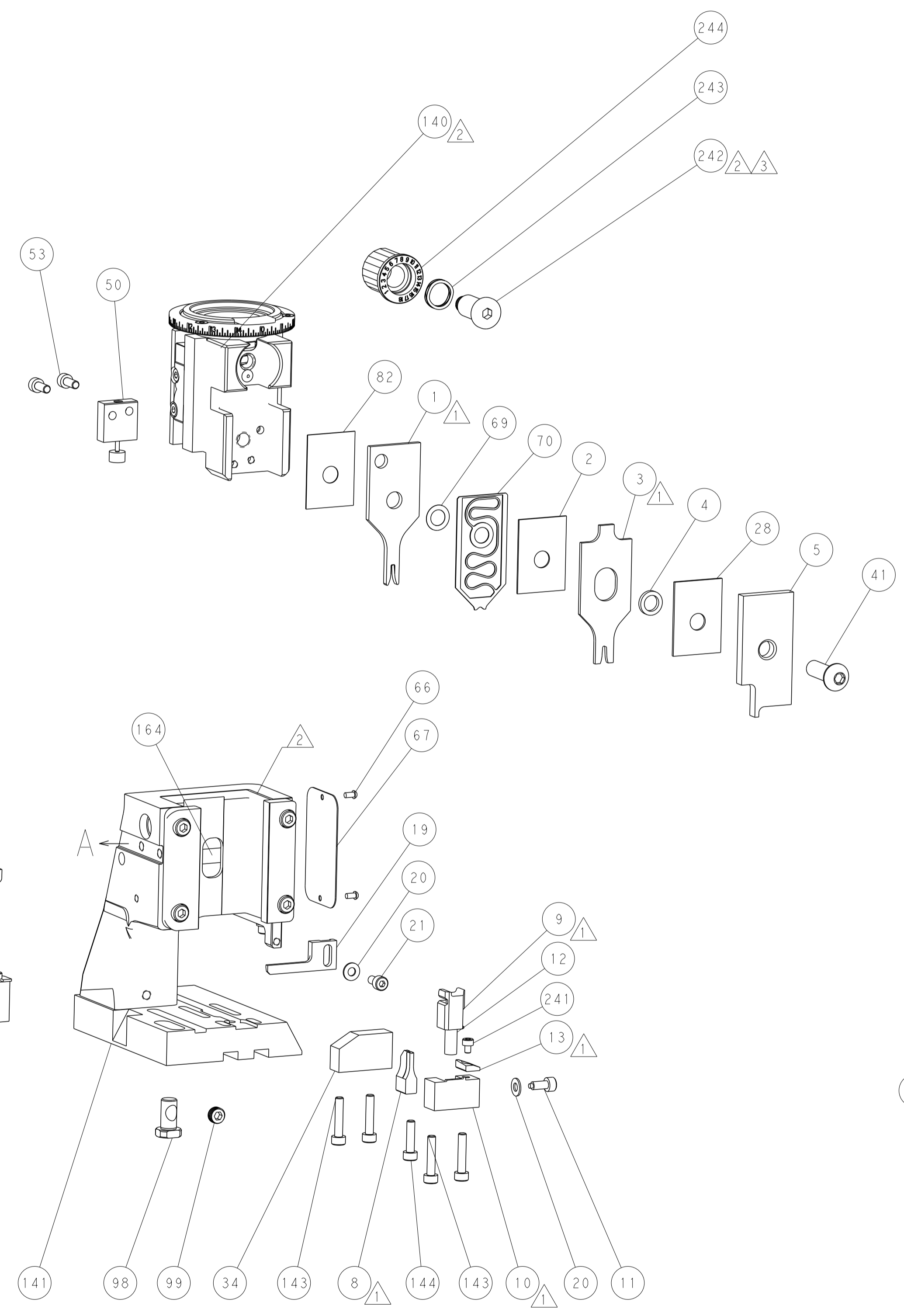
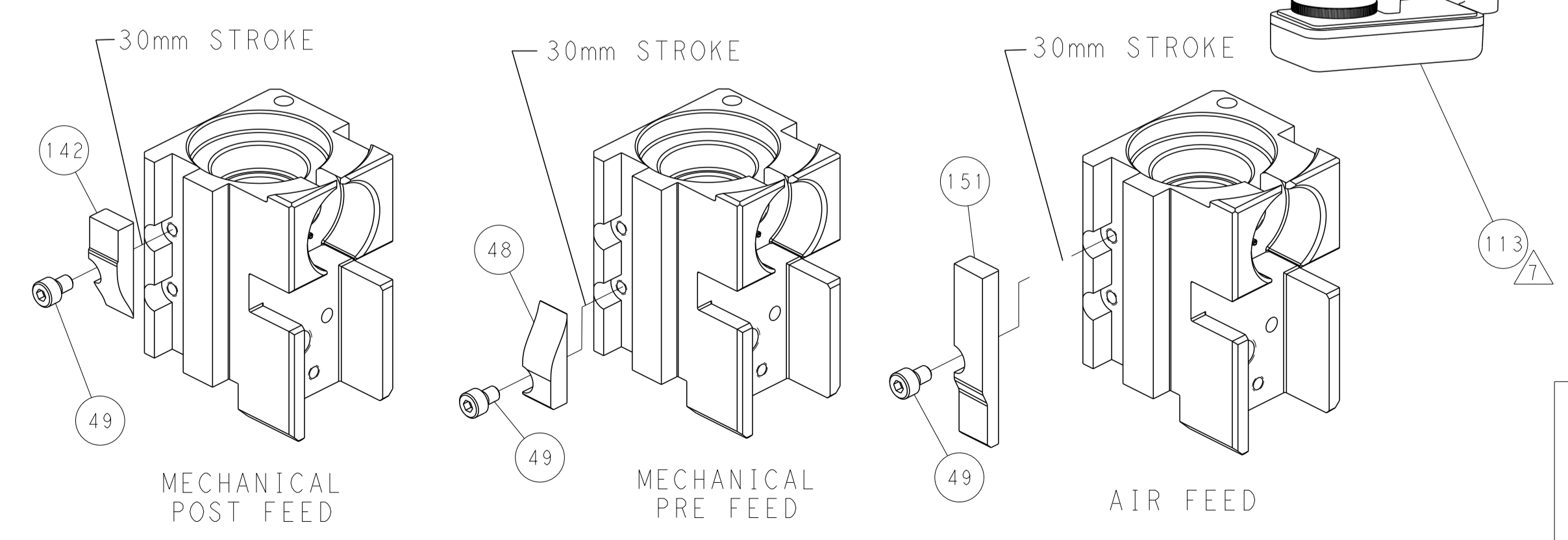

PACIFIC VERSION
 Shown on sheets 3 of 4 & 4 of 4
 (Atlantic version shown on sheets 1 of 4 & 2 of 4)

DIMENSIONS:		TOLERANCES UNLESS OTHERWISE SPECIFIED:		DWN: H. STAKEM 22OCT2012		TE Connectivity	
mm	0 PLC ±	1 PLC ±	2 PLC ±	3 PLC ±	4 PLC ±	Harrisburg, PA 17105-3608	
MATERIAL:		FINISH:		APVD: T. ELBIN 22OCT2012		NAME: Ocean Side Feed Applicator	
CUSTOMER ACCESSIBLE PRODUCTION DRAWING		SCALE: 1:2		SIZE: A1		CAGE CODE: 00779	
				DRAWING NO: 2151581		RESTRICTED TO:	
				SHEET 4 OF 4		REV E	