

| PART NUMBER | REVISION | DESCRIPTION                      | FEED TYPE  |
|-------------|----------|----------------------------------|------------|
| 2151863-1   | F        | FINE CRIMP HEIGHT ADJUST         | MECHANICAL |
| 2151863-2   | F        | FINE CRIMP HEIGHT ADJUST         | PNEUMATIC  |
| 7-2151863-1 | F        | MECHANICAL AND CRIMP TOOLING KIT | MECHANICAL |
| 7-2151863-2 | F        | PNEUMATIC AND CRIMP TOOLING KIT  | PNEUMATIC  |
| 7-2151863-7 | F        | CRIMP TOOLING KIT                | -          |

ATLANTIC VERSION TERMINATOR INTERFACE ADAPTER



| APPLICATOR DATA |                |      |
|-----------------|----------------|------|
| CRIMP           | SIZE           | TYPE |
| WIRE            | 0.84 mm [.033] | F    |
| INSUL           | 1.40 mm [.055] | O    |

APPLICATOR INSTRUCTIONS 408-35042

| TERMINAL DATA: TE TERMINAL           |             | TE CRIMP SPECIFICATION      |             |
|--------------------------------------|-------------|-----------------------------|-------------|
| TERMINAL NAME: MTE, AMPMODU, CONTACT |             |                             |             |
| WIRE STRIP LENGTH                    |             | INSULATION DIAMETER RANGE   |             |
| 3.18-3.96 mm [.125-.156 IN]          |             | Ø 1.37 mm MAX [.054 IN MAX] |             |
| TERMINAL APPLICATION SPECIFICATION   | 114-25021   |                             |             |
| TERMINALS APPLIED                    |             |                             |             |
| TE TERMINAL                          | TE TERMINAL | TE TERMINAL                 | TE TERMINAL |
| 104506-2                             | 104506-4    | 104506-6                    | 104506-8    |
| 1-104506-0                           | 5-104506-2  | 5-104506-4                  | 5-104506-6  |

| WIRE SIZE | CRIMP HEIGHT mm [INCH]         | CRIMP HEIGHT REFERENCE SETTING |
|-----------|--------------------------------|--------------------------------|
| 28 AWG    | 0.56 +/- 0.025 [.022 +/- .001] | 10.8                           |
| 30 AWG    | 0.56 +/- 0.025 [.022 +/- .001] | 10.9                           |
| 32 AWG    | 0.56 +/- 0.025 [.022 +/- .001] | 11.0                           |

- 1 RECOMMENDED SPARE PARTS
- 2 REFER TO SUPPLIED INSTRUCTION SHEET FOR CLEANING, LUBRICATION AND STORAGE OF APPLICATOR.
- 3 APPLY PART NUMBER 2-23419-6 LOCTITE TO THREADS OF ITEM 242.
- 4 CRIMP HEIGHT REFERENCE SETTING WAS THE SETTING USED WHEN THE APPLICATOR WAS QUALIFIED AT THE FACTORY. ADJUSTMENT MAY BE NECESSARY WHEN RUNNING APPLICATOR IN THE FIELD.
- 5 TERMINAL LUBRICANT IS RECOMMENDED.
- 6. UNLESS SPECIFIED OTHERWISE TORQUE VALUES SHALL BE USED PER DOCUMENT, 101-35000.

**\*WARNING**  
ON INSTALLATION, SET WIRE DISC TO CRIMP HEIGHT REFERENCE SETTING FOR LARGEST WIRE SIZE. CRIMP HEIGHT REFERENCE SETTINGS GREATER THAN THE VALUE SHOWN MAY CAUSE DAMAGE TO THE CRIMP TOOLING, REFER TO THE INSTRUCTION SHEET FOR PROPER SETUP AND ADJUSTMENTS.

ATLANTIC VERSION  
Shown on sheets 1 of 4 & 2 of 4  
(Pacific version shown on sheets 3 of 4 & 4 of 4)

| LOC | DIST | REVISIONS |     |               |           |     |      |
|-----|------|-----------|-----|---------------|-----------|-----|------|
| A   | 66   | P         | LTN | DESCRIPTION   | DATE      | DWN | APVD |
|     |      | C         |     | ECR-14-005785 | 18APR2014 | YY  | TE   |
|     |      | D         |     | ECR-18-018816 | 30NOV2018 | FL  | CT   |
|     |      | E         |     | ECR-19-000142 | 04JAN2019 | JAH | GB   |
|     |      | F         |     | ECR-21-006576 | 28JUN2021 | TB  | GB   |

|   |     |     |     |     |             |                                     |         |
|---|-----|-----|-----|-----|-------------|-------------------------------------|---------|
| - | 1   | 1   | 1   | 1   | 1803945-4   | TONKER                              | 300     |
| - | 1   | 1   | 1   | 1   | 22278-9     | SPRING, COMPRESSION                 | 299     |
| - | 2   | 2   | 2   | 2   | 4-18032-3   | SCR, SET, FLT PNT, M3 X 6.0         | 298     |
| - | 1   | 1   | 1   | 1   | 1803944-1   | SPACER, TONKER                      | 297     |
| - | 1   | -   | 1   | -   | 2119641-1   | FEED CAM, AIR FEED                  | 248     |
| - | 1   | 1   | 1   | 1   | 2119082-9   | CAM, SNAIL, INSULATION ADJUSTMENT   | 244     |
| - | 1   | 1   | 1   | 1   | 2079764-1   | WASHER, WAVE SPRING, CREST-TO-CREST | 243     |
| - | 1   | 1   | 1   | 1   | 2119083-1   | RETAINER, INSULATION DIAL           | 242     |
| - | 1   | 1   | 1   | 1   | 7-18023-7   | SCR, SKT HD CAP M3 X 4.0            | 241     |
| - | -   | 1   | -   | 1   | 2119580-1   | MECHANICAL FEED ASSEMBLY            | 239     |
| - | 1   | -   | 1   | -   | 2844940-1   | AIR FEED MODULE                     | 238     |
| - | REF | REF | REF | REF | 994970-2    | COUNTER, MAGNETIC                   | 164     |
| - | 1   | 1   | 1   | 1   | 2119955-1   | ASSY, LUBRICATOR, SIDE FEED         | 113     |
| - | 1   | 1   | 1   | 1   | 2844908-1   | SCREW, LOCKING                      | 99      |
| - | 1   | 1   | 1   | 1   | 2844907-1   | POST, LOCKING                       | 98      |
| - | 1   | 1   | 1   | 1   | 455888-5    | SPACER, CRIMPER                     | 82      |
| - | 1   | 1   | 1   | 1   | 1803607-3   | DOCUMENTATION PACKAGE               | 71      |
| - | 1   | 1   | 1   | 1   | 2119740-1   | TAG, IDENTIFICATION                 | 67      |
| - | 2   | 2   | 2   | 2   | 2168078-1   | SCREW, DRIVE, RH, RoHS, 2 x .188    | 66      |
| - | 1   | 1   | 1   | 1   | 2168083-2   | SCR, SKT HD CAP, RoHS, M4 X 8.0     | 60      |
| - | 1   | 1   | 1   | 1   | 5-18022-5   | SCR, HEX HD CAP, M4 X 6.0           | 59      |
| - | 1   | 1   | 1   | 1   | 1338685-1   | PAWL, FEED                          | 56      |
| - | 4   | 4   | 4   | 4   | 2168083-3   | SCR, SKT HD CAP, RoHS, M4 X 12.0    | 54      |
| - | 2   | 2   | 2   | 2   | 2-2168083-6 | SCR, SKT HD CAP, RoHS, M4 X 18      | 53      |
| - | 1   | 2   | 1   | 2   | 18023-9     | SCR, SKT HD CAP M4 X 6.0            | 49      |
| - | -   | 1   | -   | 1   | 2119652-1   | FEED CAM, PRE FEED                  | 48      |
| - | -   | 1   | -   | 1   | 2119653-1   | FEED CAM, POST FEED                 | 47      |
| - | 1   | 1   | 1   | 1   | 1803583-9   | APPLICATOR BASIC ASSEMBLY, SF       | 46      |
| - | 1   | 1   | 1   | 1   | 1803515-1   | RAM ASSEMBLY, SF ATLANTIC           | 44      |
| - | 1   | 1   | 1   | 1   | 1803602-1   | SCR, BHSC, RoHS (M8 X 25)           | 41      |
| - | 1   | 1   | 1   | 1   | 1-1752356-9 | SUPPORT, TERMINAL                   | 34      |
| - | 2   | 2   | 2   | 2   | 2079383-5   | SCR, BHSC, RoHS (M4 X 20)           | 33      |
| - | 2   | 2   | 2   | 2   | 2-2844962-3 | SPACER, CYLINDRICAL, STRIP GUIDE    | 30      |
| - | 1   | 1   | 1   | 1   | 2844992-1   | ASSEMBLY, STRIP GUIDE               | 29      |
| - | 1   | 1   | 1   | 1   | 1-455888-0  | SPACER, CRIMPER                     | 28      |
| - | 1   | 1   | 1   | 1   | 1320928-2   | STRIP GUIDE                         | 24      |
| - | 1   | 1   | 1   | 1   | 2168083-2   | SCR, SKT HD CAP, RoHS, M4 X 8.0     | 21      |
| - | 2   | 2   | 2   | 2   | 1-18028-2   | WASHER, FLAT, REG M4                | 20      |
| - | 1   | 1   | 1   | 1   | 2119533-1   | STRIPPER, SIDE FEED                 | 19      |
| - | 1   | 1   | 1   | 1   | 2119806-1   | INSERT, SHEAR                       | 13      |
| - | 1   | 1   | 1   | 1   | 3-22280-3   | SPRING, COMPRESSION                 | 12      |
| - | 1   | 1   | 1   | 1   | 1-356885-4  | STOP, SHEAR                         | 11      |
| - | 1   | 1   | 1   | 1   | 2119805-1   | SHEAR HOLDER, FRONT                 | 10      |
| - | 1   | 1   | 1   | 1   | 1633861-3   | SHEAR, FLOATING                     | 9       |
| - | 1   | 2   | 2   | 1   | 1803057-6   | ANVIL, COMBINATION                  | 8       |
| - | 1   | 1   | 1   | 1   | 1-240641-8  | SPACER                              | 7       |
| - | -   | -   | -   | -   | -           | -                                   | 6       |
| - | 1   | 1   | 1   | 1   | 2119757-1   | DEPRESSOR, SHEAR                    | 5       |
| - | 1   | 1   | 1   | 1   | 238011-7    | BLOCK, CRIMPER SPACER               | 4       |
| - | 1   | 2   | 2   | 1   | 1-1803019-8 | CRIMPER, INSULATION O               | 3       |
| - | 1   | 1   | 1   | 1   | 455888-3    | SPACER, CRIMPER                     | 2       |
| - | 1   | 2   | 2   | 1   | 4-1803224-4 | CRIMPER, WIRE                       | 1       |
| - | 77  | 72  | 71  | -2  | -1          | PART NO                             | ITEM NO |

| DIMENSIONS: |         | TOLERANCES UNLESS OTHERWISE SPECIFIED: |         | MATERIAL: |         | FINISH:  |          |
|-------------|---------|--|---------|-----------|---------|----------|----------|
| mm          | 0 PLC ± | 1 PLC ±                                | 2 PLC ± | 3 PLC ±   | 4 PLC ± | ANGLES ± | FINISH ± |

|  |           |            |               |                            |           |       |        |           |   |
|--|-----------|------------|---------------|----------------------------|-----------|-------|--------|-----------|---|
| OWN                                    | H. HUANG  | 28JAN2013  | CHK           | S. XI                      | 28JAN2013 | APVD  | S. XI  | 28JAN2013 |   |
| NAME                                   |           |            |               | Ocean Side Feed Applicator |           |       |        |           |   |
| SIZE                                   | CAGE CODE | DRAWING NO | RESTRICTED TO |                            |           |       |        |           |   |
| A1                                     | 00779     | 2151863    |               |                            |           |       |        |           |   |
| Customer Accessible Production Drawing |           |            |               | SCALE                      | 1:2       | SHEET | 1 OF 4 | REV       | F |

| LOC |    | DIST |     | REVISIONS   |      |     |      |
|-----|----|------|-----|-------------|------|-----|------|
| A   | 66 | P    | LYN | DESCRIPTION | DATE | OWN | APVD |
|     |    | -    |     | SEE SHEET 1 |      |     |      |

# FEED TYPE MECHANICAL

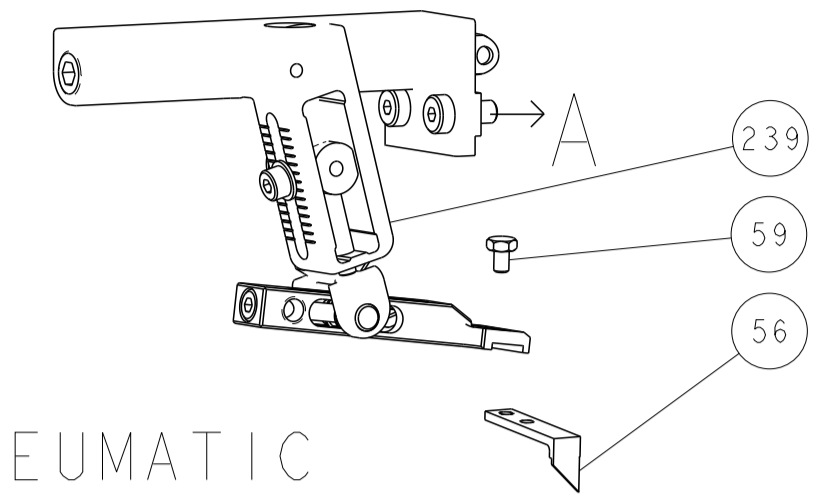

## PNEUMATIC

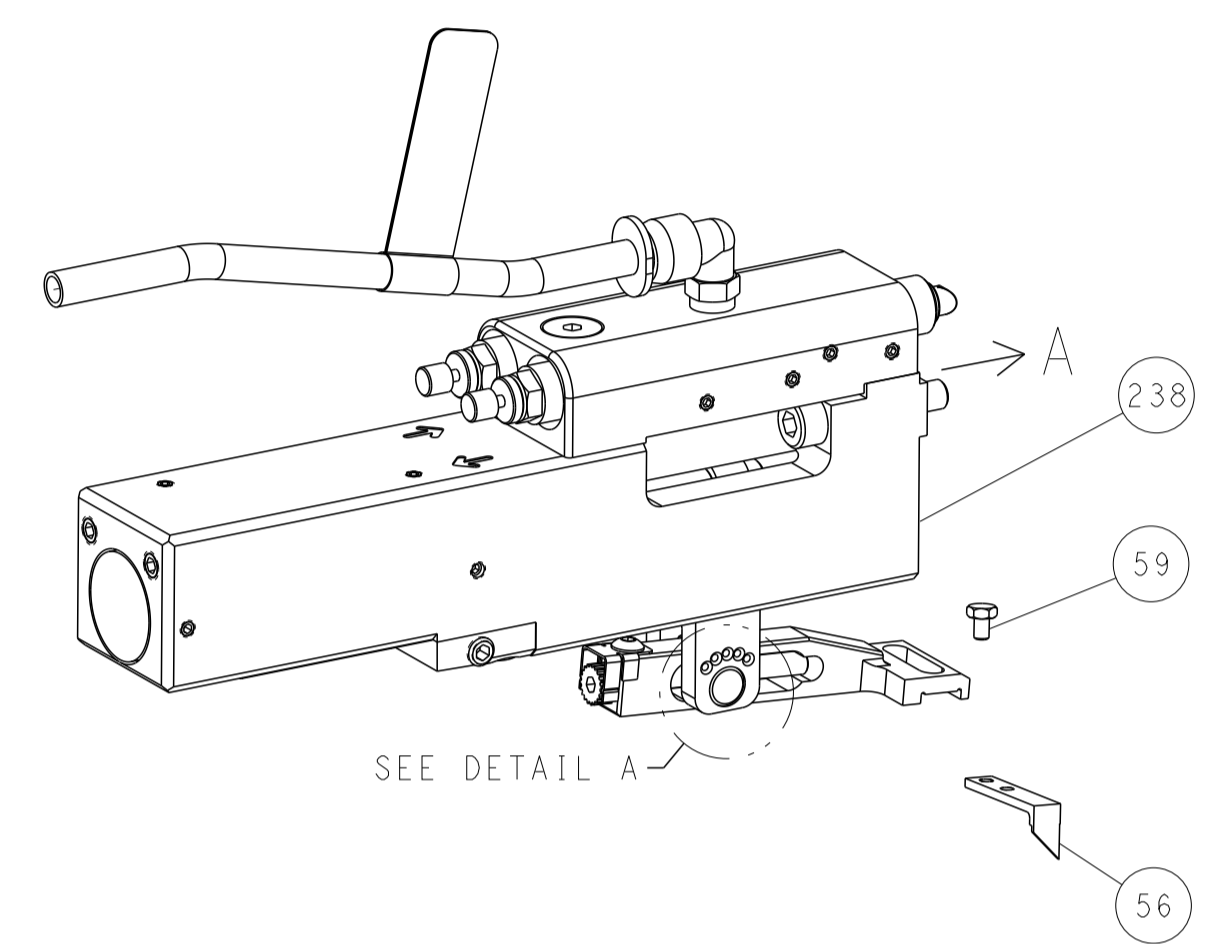

## FEED SPRING SETTING POSITION (SHOWN FROM REAR SIDE)

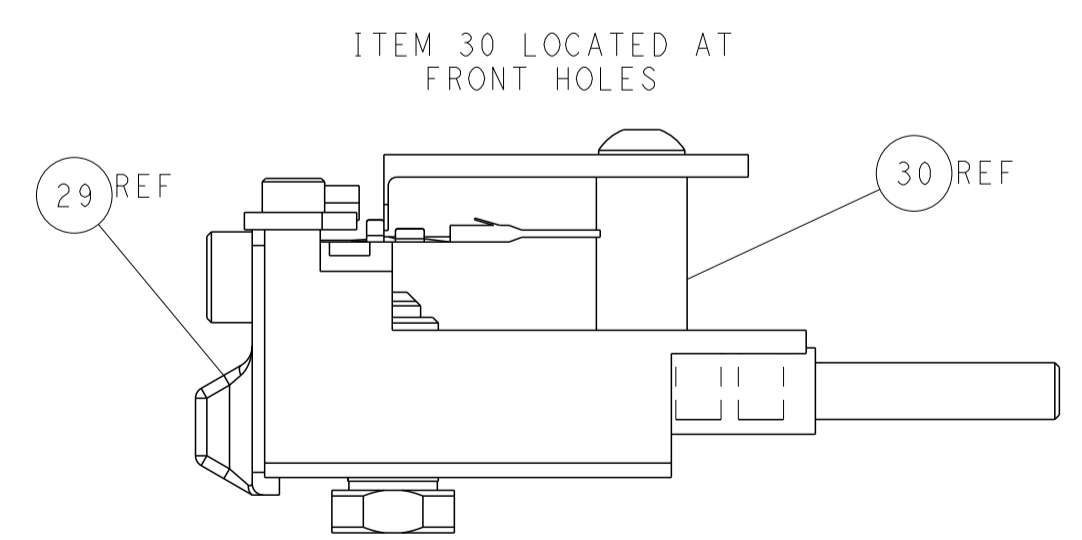
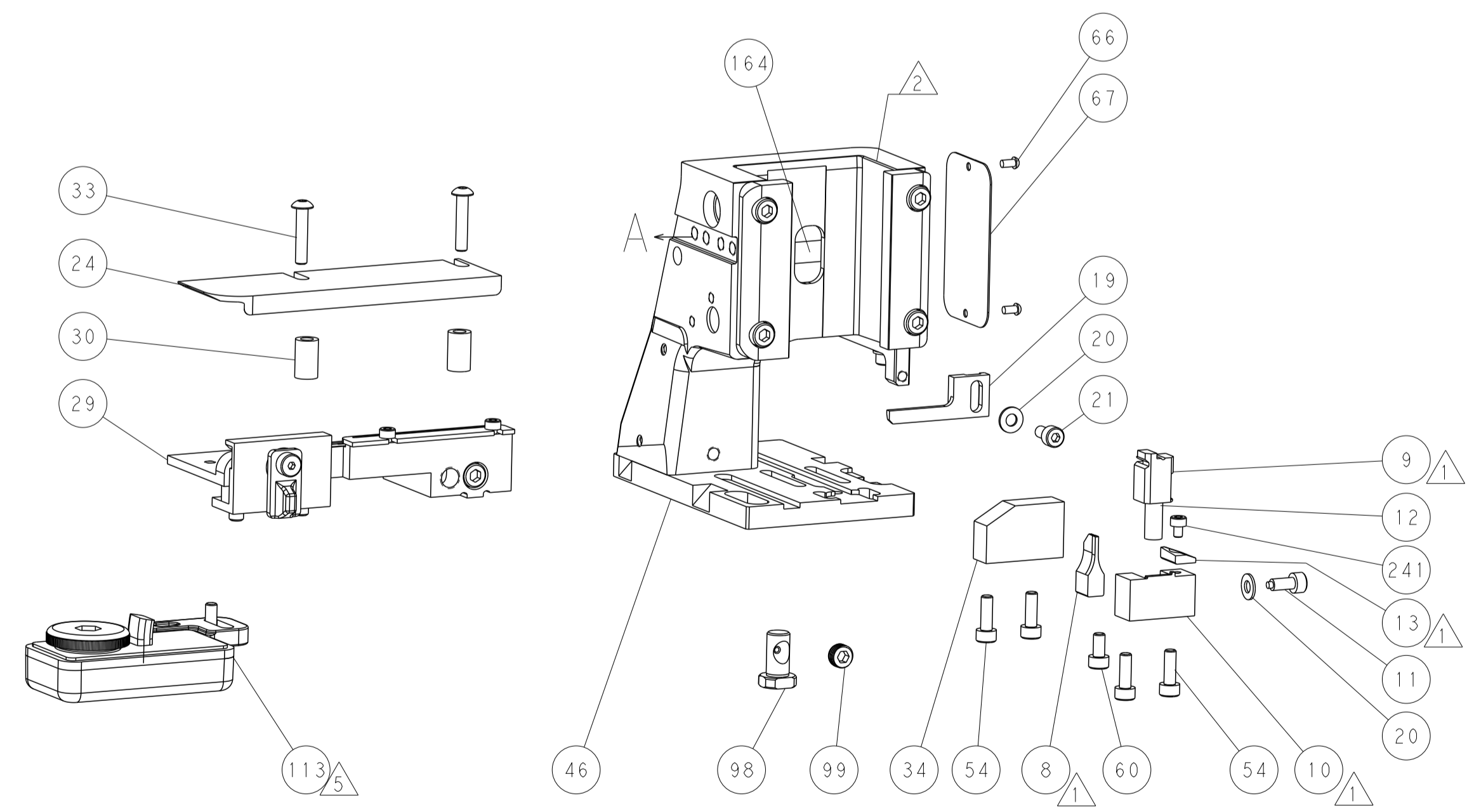
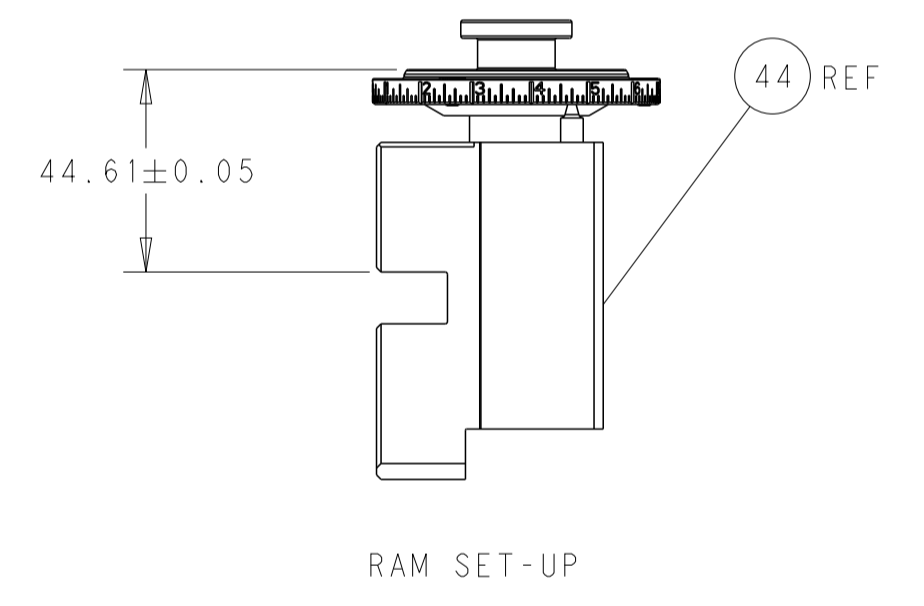
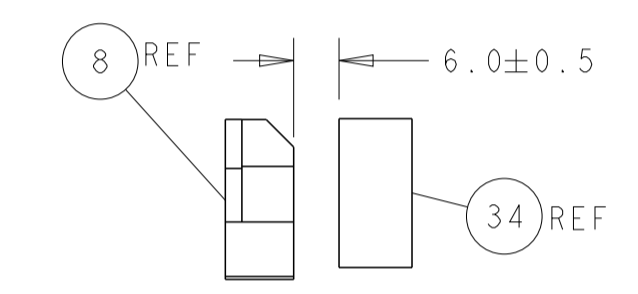
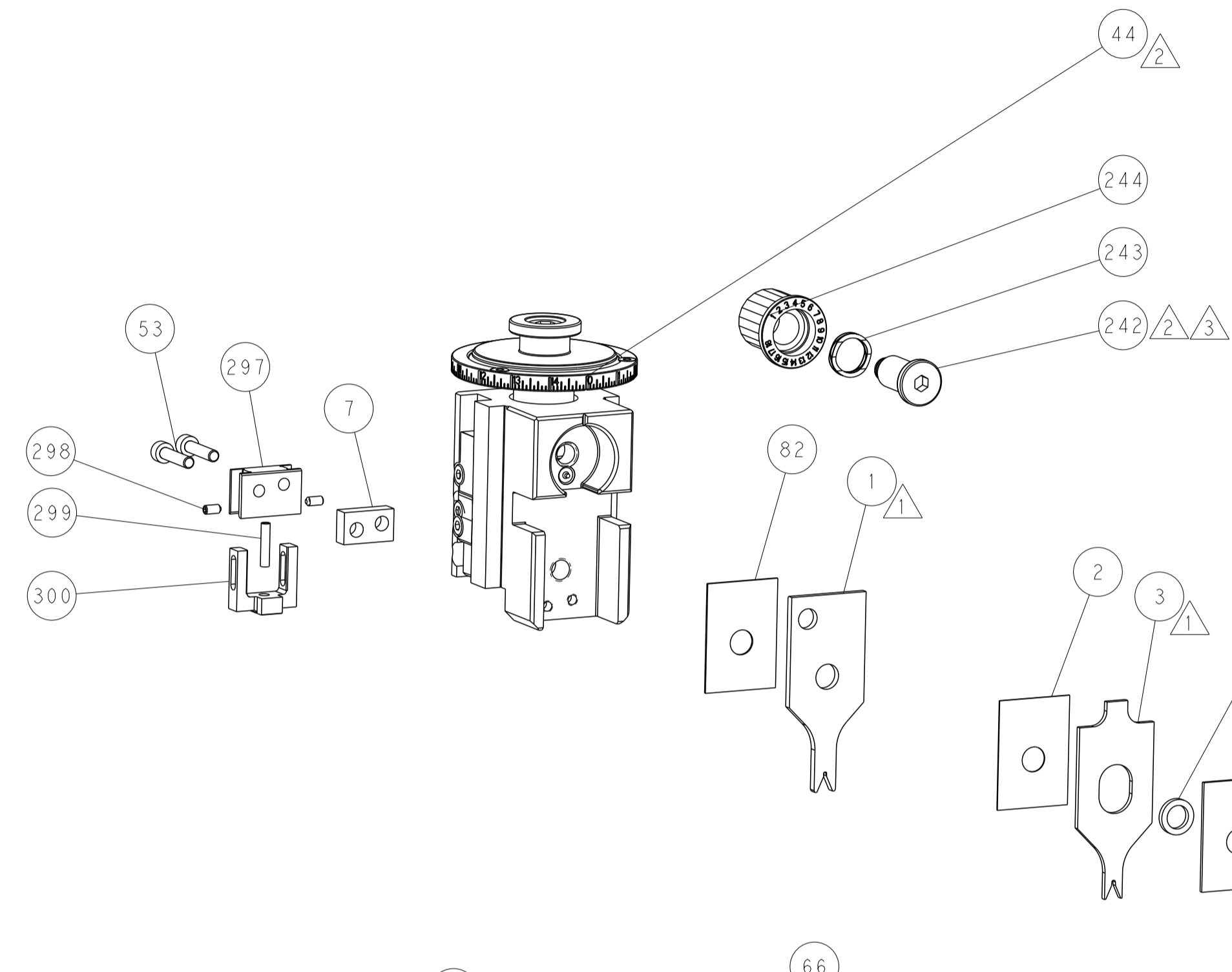
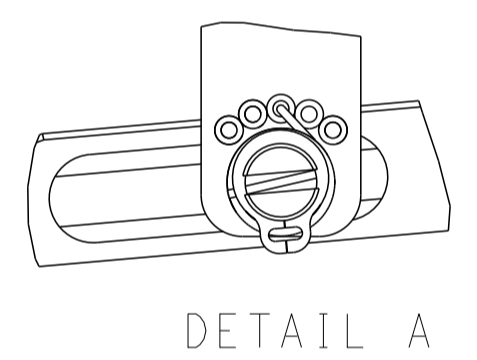

# CAM POSITIONS

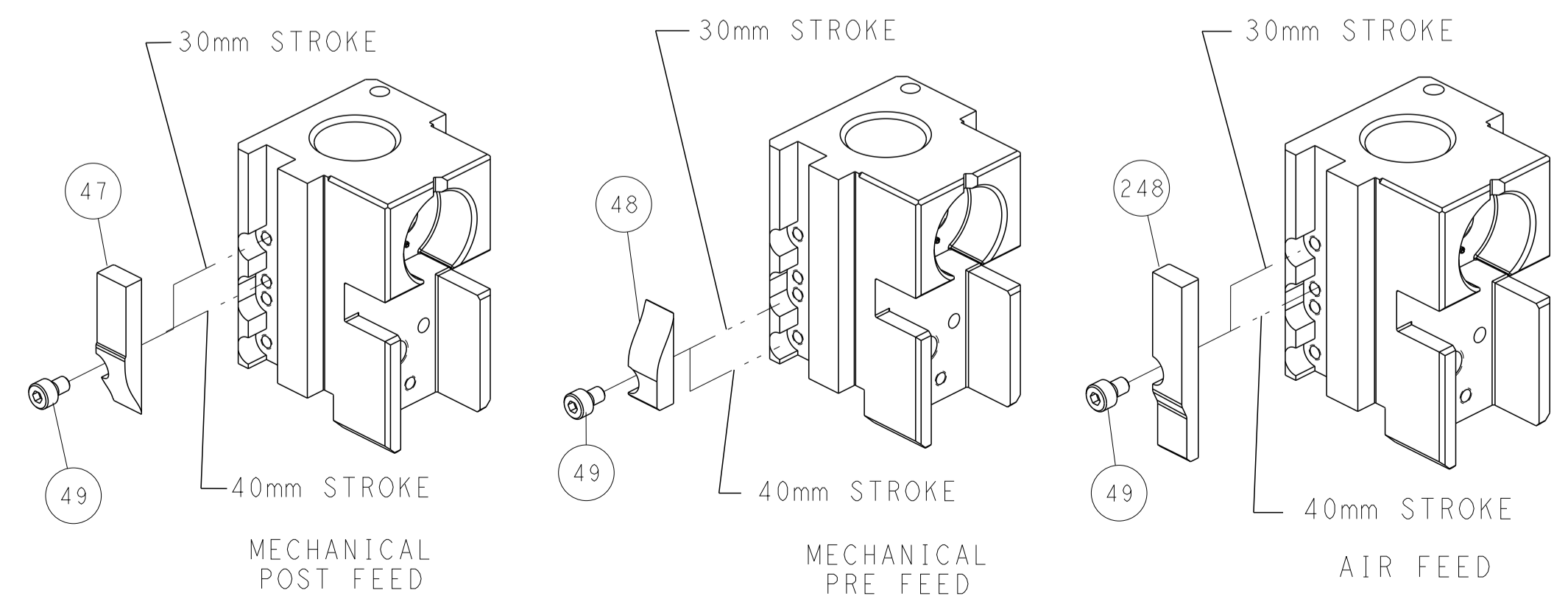

**ATLANTIC VERSION**  
 Shown on sheets 1 of 4 & 2 of 4  
 (Pacific version shown on sheets 3 of 4 & 4 of 4)

|  |         |  |         |                              |         |  |               |
|--|---------|--|---------|------------------------------|---------|--|---------------|
| DIMENSIONS:                            |         | TOLERANCES UNLESS OTHERWISE SPECIFIED: |         | DWN<br>R. HUANG<br>28JAN2013 |         | TE Connectivity<br>Harrisburg, PA 17105-3608 |               |
| mm                                     | 0 PLC ± | 1 PLC ±                                | 2 PLC ± | 3 PLC ±                      | 4 PLC ± | NAME<br>Ocean Side Feed<br>Applicator        | RESTRICTED TO |
|  | ANGLES  | FINISH                                 |         | WEIGHT                       |         | SIZE<br>A1                                   |               |
| MATERIAL                               |         |  |         | CAGE CODE<br>00779           |         | DRAWING NO<br>2151863                        |               |
| Customer Accessible Production Drawing |         |  |         | SCALE                        | 1:2     | SHEET  | 2 of 4        |
|  |         |  |         | REV                          | F       |  |               |

| PART NUMBER | REVISION | DESCRIPTION              | FEED TYPE  |
|-------------|----------|--------------------------|------------|
| 2-2151863-1 | F        | FINE CRIMP HEIGHT ADJUST | MECHANICAL |
| 2-2151863-2 | F        | FINE CRIMP HEIGHT ADJUST | PNEUMATIC  |
| 7-2151863-7 | F        | CRIMP TOOLING KIT        | -          |

PACIFIC VERSION TERMINATOR  
 INTERFACE ADAPTER



| APPLICATOR DATA |                |      |
|-----------------|----------------|------|
| CRIMP           | SIZE           | TYPE |
| WIRE            | 0.84 mm [.033] | F    |
| INSUL           | 1.40 mm [.055] | O    |

APPLICATOR INSTRUCTIONS  
 408-35042

| TERMINAL DATA: TE TERMINAL TE CRIMP SPECIFICATION |                             |             |             |
|---|-----------------------------|-------------|-------------|
| TERMINAL NAME: MTE, AMPMODU, CONTACT              |                             |             |             |
| WIRE STRIP LENGTH                                 | INSULATION DIAMETER RANGE   |             |             |
| 3.18-3.96 mm [1.25-.156 IN]                       | ∅ 1.37 mm MAX [.054 IN MAX] |             |             |
| TERMINAL APPLICATION SPECIFICATION                | 114-25021                   | -           | -           |
| TERMINALS APPLIED                                 |                             |             |             |
| TE TERMINAL                                       | TE TERMINAL                 | TE TERMINAL | TE TERMINAL |
| 104506-2  | 104506-4                    | 104506-6    | 104506-8    |
| 1-104506-0  | 5-104506-2                  | 5-104506-4  | 5-104506-6  |

| WIRE SIZE | CRIMP HEIGHT mm [INCH]      | CRIMP HEIGHT REFERENCE SETTING |
|-----------|-----------------------------|--------------------------------|
| 28 AWG    | 0.56+/-0.025 [.022+/- .001] | 10.8                           |
| 30 AWG    | 0.56+/-0.025 [.022+/- .001] | 10.9                           |
| 32 AWG    | 0.56+/-0.025 [.022+/- .001] | 11.0                           |

- 1. RECOMMENDED SPARE PARTS
- 2. REFER TO SUPPLIED INSTRUCTION SHEET FOR CLEANING, LUBRICATION AND STORAGE OF APPLICATOR.
- 3. APPLY PART NUMBER 2-23419-6 LOCTITE TO THREADS OF ITEM 242.
- 4. CRIMP HEIGHT REFERENCE SETTING WAS THE SETTING USED WHEN THE APPLICATOR WAS QUALIFIED AT THE FACTORY. ADJUSTMENT MAY BE NECESSARY WHEN RUNNING APPLICATOR IN THE FIELD.
- 5. TERMINAL LUBRICANT IS RECOMMENDED.
- 6. UNLESS SPECIFIED OTHERWISE TORQUE VALUES SHALL BE USED PER DOCUMENT, 101-35000.

**\*WARNING**  
 ON INSTALLATION, SET WIRE DISC TO CRIMP HEIGHT REFERENCE SETTING FOR LARGEST WIRE SIZE. CRIMP HEIGHT REFERENCE SETTINGS GREATER THAN THE VALUE SHOWN MAY CAUSE DAMAGE TO THE CRIMP TOOLING. REFER TO THE INSTRUCTION SHEET FOR PROPER SETUP AND ADJUSTMENTS.

| LOC | DIST | REVISIONS |     |             |      |     |      |
|-----|------|-----------|-----|-------------|------|-----|------|
| A   | 66   | P         | LTN | DESCRIPTION | DATE | OWN | APVD |
| -   | -    | -         | -   | SEE SHEET 1 | -    | -   | -    |

|   |     |     |             |                                     |     |
|---|-----|-----|-------------|-------------------------------------|-----|
| - | 1   | 1   | 1803945-4   | TONKER                              | 300 |
| - | 1   | 1   | 22278-9     | SPRING, COMPRESSION                 | 299 |
| - | 2   | 2   | 4-18032-3   | SCR, SET, FLT PNT, M3 X 6.0         | 298 |
| - | 1   | 1   | 1803944-1   | SPACER, TONKER                      | 297 |
| - | 1   | 1   | 2119082-9   | CAM, SNAIL, INSULATION ADJUSTMENT   | 244 |
| - | 1   | 1   | 2079764-1   | WASHER, WAVE SPRING, CREST-TO-CREST | 243 |
| - | 1   | 1   | 2119083-1   | RETAINER, INSULATION DIAL           | 242 |
| - | 1   | 1   | 7-18023-7   | SCR, SKT HD CAP M3 X 4.0            | 241 |
| - | -   | 1   | 2119580-1   | MECHANICAL FEED ASSEMBLY            | 239 |
| - | 1   | -   | 2844940-1   | AIR FEED MODULE                     | 238 |
| - | REF | REF | 994970-2    | COUNTER, MAGNETIC                   | 164 |
| - | 1   | -   | 2119641-2   | FEED CAM, AIR FEED                  | 151 |
| - | 1   | 1   | 2168083-8   | SCR, SKT HD CAP, RoHS, M4 X 16      | 144 |
| - | 4   | 4   | 2168083-9   | SCR, SKT HD CAP, RoHS, M4 X 20      | 143 |
| - | -   | 1   | 2119653-2   | FEED CAM, POST FEED                 | 142 |
| - | 1   | 1   | 1-1803583-0 | APPLICATOR BASIC ASSEMBLY, SF       | 141 |
| - | 1   | 1   | 1803516-1   | RAM ASSEMBLY, SF PACIFIC            | 140 |
| - | 1   | 1   | 2119955-1   | ASSY, LUBRICATOR, SIDE FEED         | 113 |
| - | 1   | 1   | 2844908-1   | SCREW, LOCKING                      | 99  |
| - | 1   | 1   | 2844907-1   | POST, LOCKING                       | 98  |
| - | 1   | 1   | 455888-5    | SPACER, CRIMPER                     | 82  |
| - | 1   | 1   | 1803607-3   | DOCUMENTATION PACKAGE               | 71  |
| - | 1   | 1   | 2119740-1   | TAG, IDENTIFICATION                 | 67  |
| - | 2   | 2   | 2168078-1   | SCREW, DRIVE, RH, RoHS, 2 x .188    | 66  |
| - | 1   | 1   | 5-18022-5   | SCR, HEX HD CAP, M4 X 6.0           | 59  |
| - | 1   | 1   | 1338685-1   | PAWL, FEED                          | 56  |
| - | 2   | 2   | 2-2168083-6 | SCR, SKT HD CAP, RoHS, M4 X 18      | 53  |
| - | 1   | 2   | 18023-9     | SCR, SKT HD CAP M4 X 6.0            | 49  |
| - | -   | 1   | 2119652-1   | FEED CAM, PRE FEED                  | 48  |
| - | 1   | 1   | 1803602-1   | SCR, BHSC, RoHS (M8 X 25)           | 41  |
| - | 1   | 1   | 1-1752356-9 | SUPPORT, TERMINAL                   | 34  |
| - | 2   | 2   | 2079383-5   | SCR, BHSC, RoHS (M4 X 20)           | 33  |
| - | 2   | 2   | 2-2844962-3 | SPACER, CYLINDRICAL, STRIP GUIDE    | 30  |
| - | 1   | 1   | 2844992-1   | ASSEMBLY, STRIP GUIDE               | 29  |
| - | 1   | 1   | 1-455888-0  | SPACER, CRIMPER                     | 28  |
| - | 1   | 1   | 1320928-2   | STRIP GUIDE                         | 24  |
| - | 1   | 1   | 2168083-2   | SCR, SKT HD CAP, RoHS, M4 X 8.0     | 21  |
| - | 2   | 2   | 1-18028-2   | WASHER, FLAT, REG M4                | 20  |
| - | 1   | 1   | 2119533-1   | STRIPPER, SIDE FEED                 | 19  |
| - | 1   | 1   | 2119806-1   | INSERT, SHEAR                       | 13  |
| - | 1   | 1   | 3-22280-3   | SPRING, COMPRESSION                 | 12  |
| - | 1   | 1   | 1-356885-4  | STOP, SHEAR                         | 11  |
| - | 1   | 1   | 2119805-1   | SHEAR HOLDER, FRONT                 | 10  |
| - | 1   | 1   | 1633861-3   | SHEAR, FLOATING                     | 9   |
| - | 1   | 1   | 1803057-6   | ANVIL, COMBINATION                  | 8   |
| - | 1   | 1   | 1-240641-8  | SPACER                              | 7   |
| - | -   | -   | -           | -                                   | 6   |
| - | 1   | 1   | 2119757-1   | DEPRESSOR, SHEAR                    | 5   |
| - | 1   | 1   | 238011-7    | BLOCK, CRIMPER SPACER               | 4   |
| - | 1   | 1   | 1-1803019-8 | CRIMPER, INSULATION O               | 3   |
| - | 1   | 1   | 455888-3    | SPACER, CRIMPER                     | 2   |
| - | 1   | 1   | 4-1803224-4 | CRIMPER, WIRE                       | 1   |

PACIFIC VERSION  
 Shown on sheets 3 of 4 & 4 of 4  
 (Atlantic version shown on sheets 1 of 4 & 2 of 4)

|  |         |  |         |                         |         |                                  |  |
|--|---------|--|---------|-------------------------|---------|----------------------------------|--|
| DIMENSIONS:                            |         | TOLERANCES UNLESS OTHERWISE SPECIFIED: |         | DWG: H. HUANG 28JAN2013 |         | REV: S. XI 28JAN2013             |  |
| mm                                     | 0 PLC ± | 1 PLC ±                                | 2 PLC ± | 3 PLC ±                 | 4 PLC ± | NAME: Ocean Side Feed Applicator |  |
| MATERIAL:                              |         |  |         | WEIGHT:                 |         | SCALE: 1:2                       |  |
| FINISH:                                |         |  |         | CAGE CODE: 00779        |         | DRAWING NO: 2151863              |  |
| Customer Accessible Production Drawing |         |  |         | SHEET 3 OF 4            |         | REV F                            |  |

| LOC | DIST | REVISIONS |     |             |      |     |      |
|-----|------|-----------|-----|-------------|------|-----|------|
| A   | 66   | P         | LTN | DESCRIPTION | DATE | DWN | APVD |
|     |      | -         |     | SEE SHEET 1 |      |     |      |

# FEED TYPE MECHANICAL

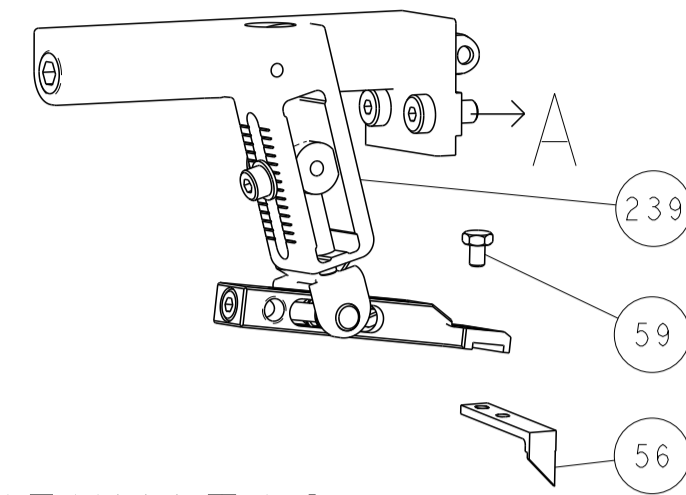

## PNEUMATIC

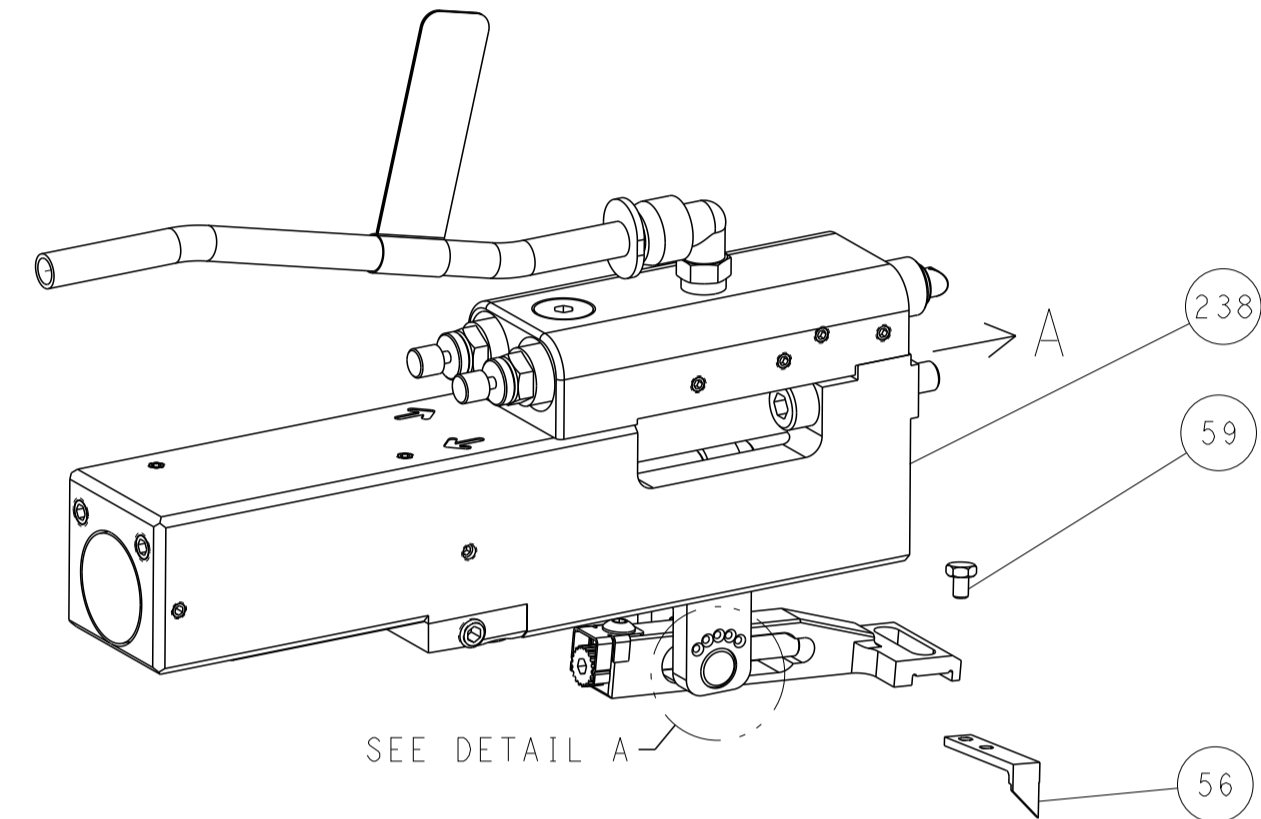

## FEED SPRING SETTING POSITION (SHOWN FROM REAR SIDE)

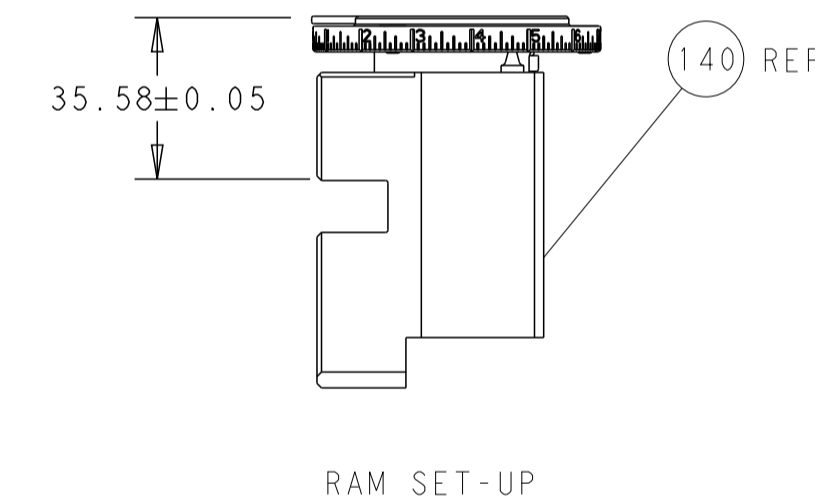
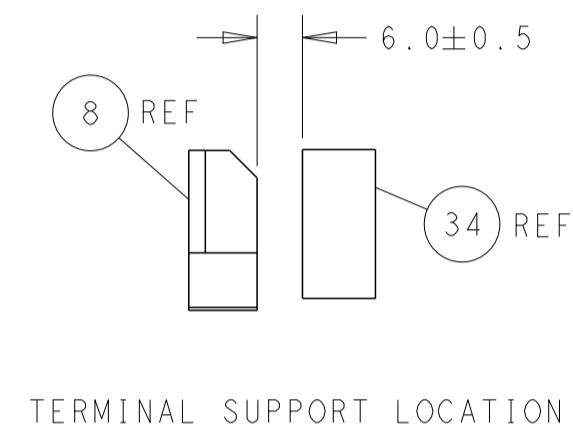
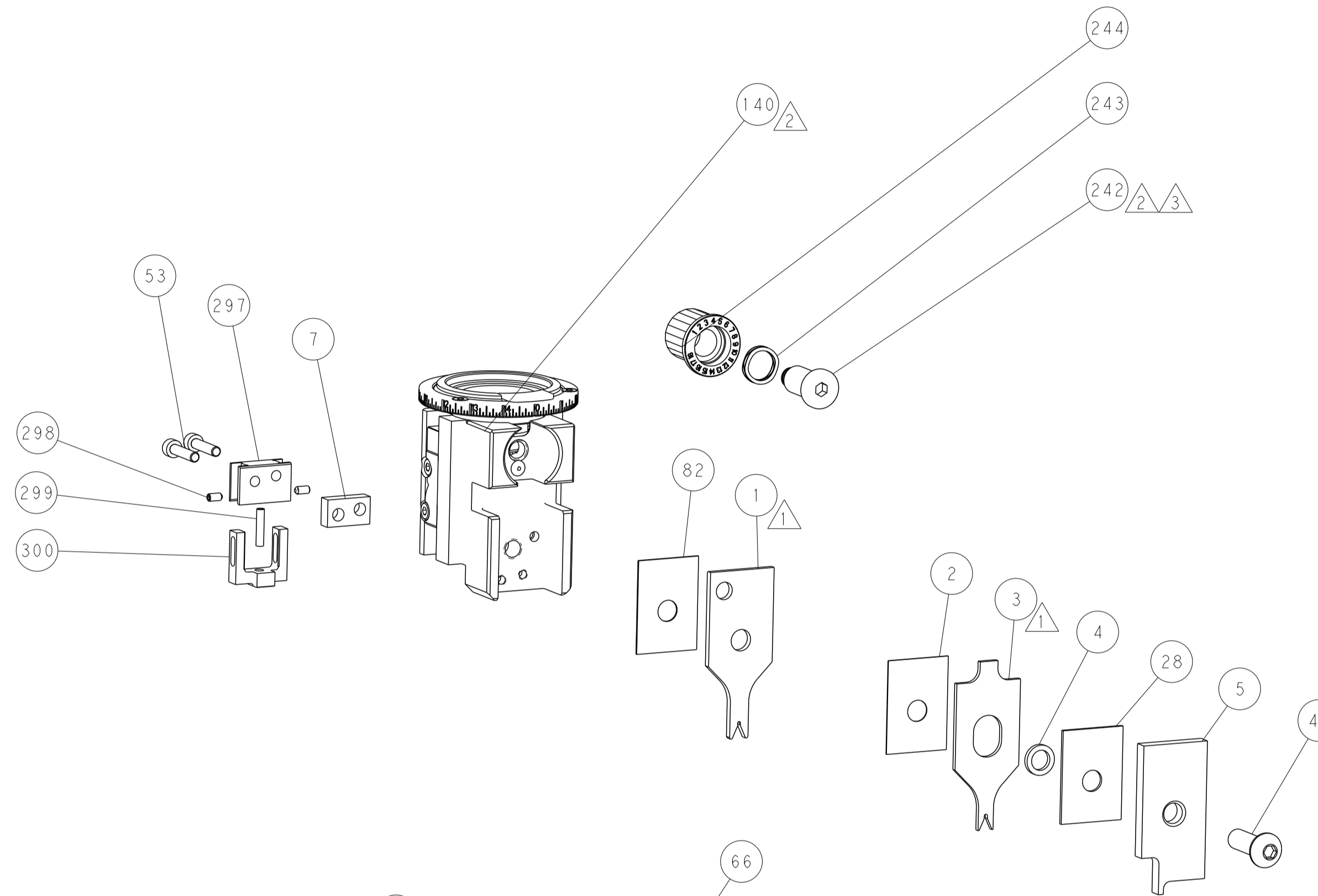
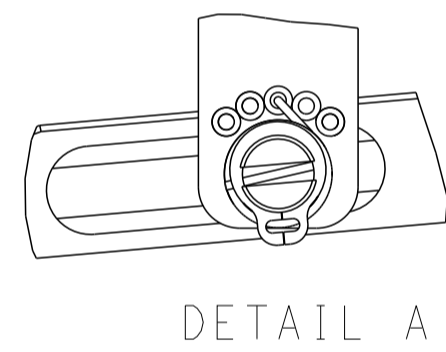

## CAM POSITIONS

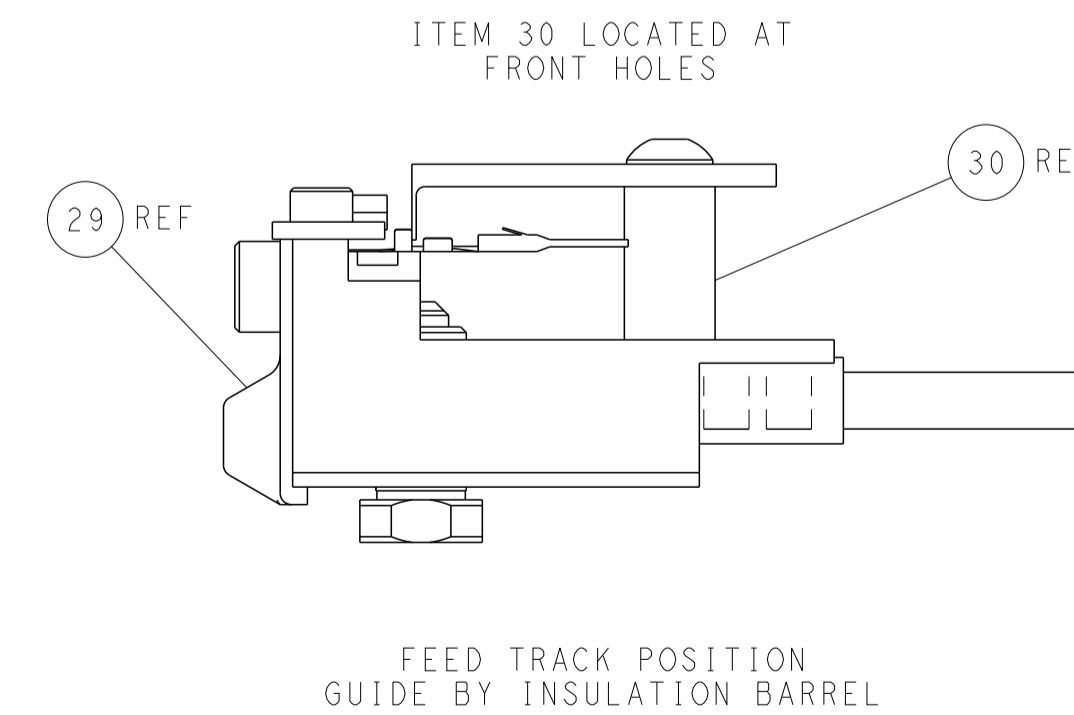
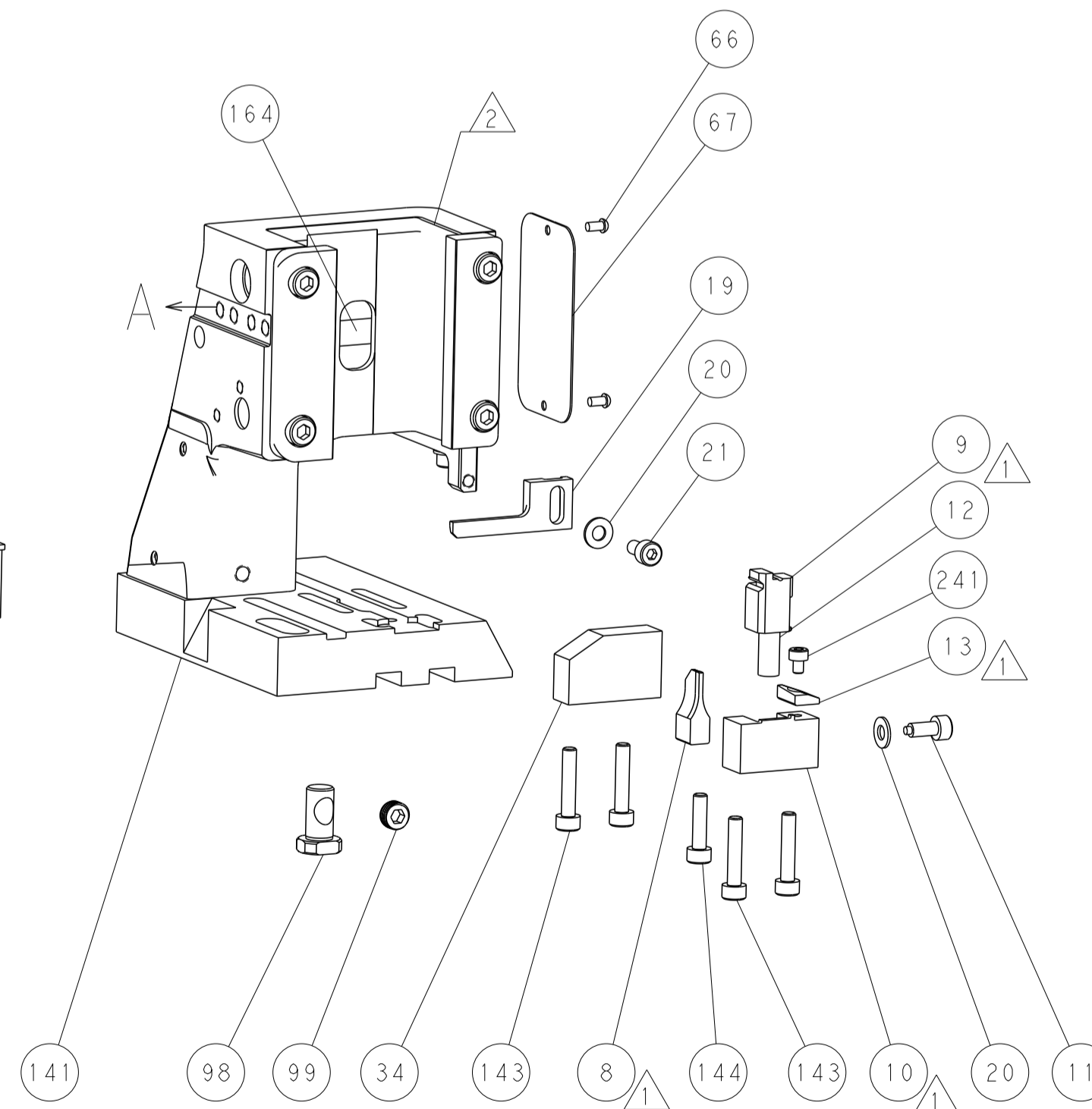
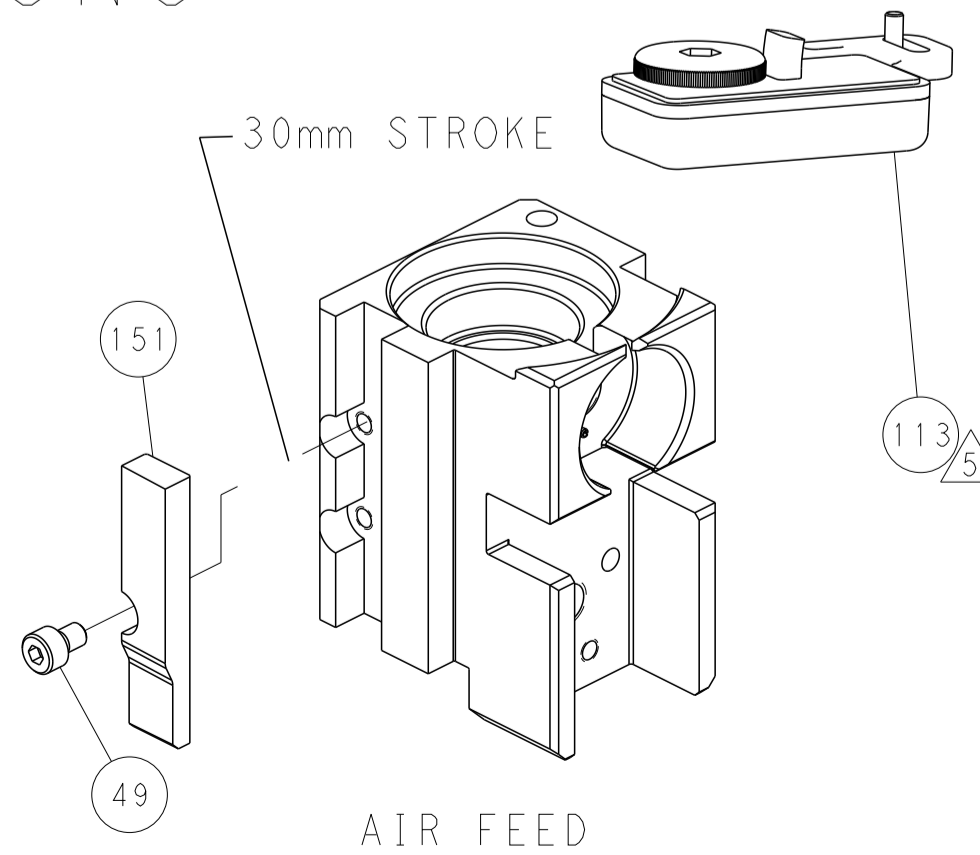
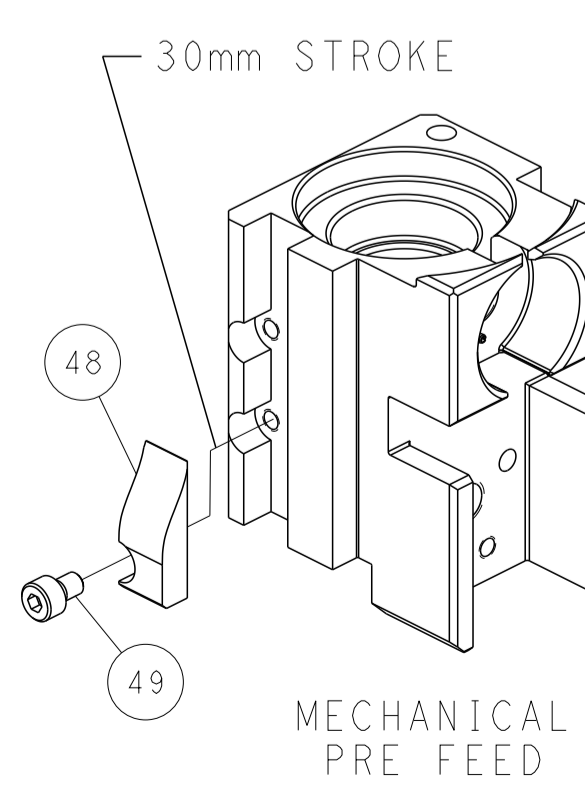
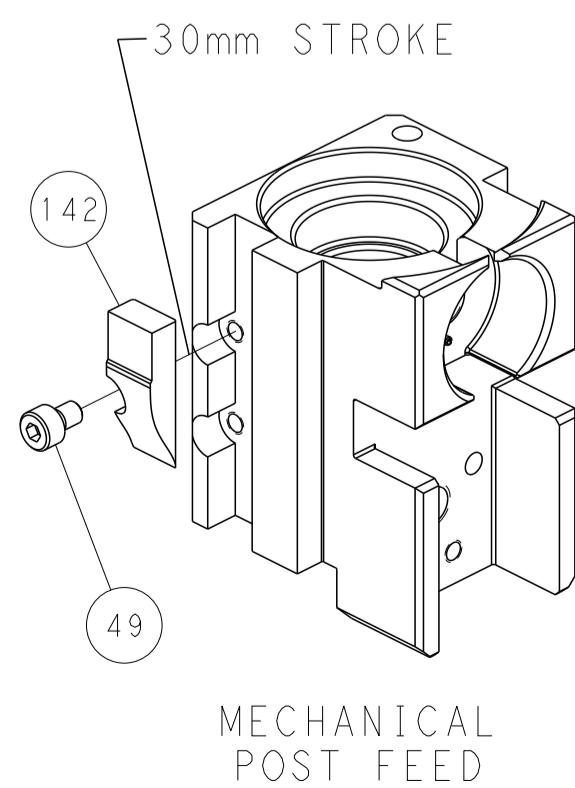

**PACIFIC VERSION**  
 Shown on sheets 3 of 4 & 4 of 4  
 (Atlantic version shown on sheets 1 of 4 & 2 of 4)

|             |         |  |         |  |              |                            |                           |
|-------------|---------|--|---------|--|--------------|----------------------------|---------------------------|
| DIMENSIONS: |         | TOLERANCES UNLESS OTHERWISE SPECIFIED: |         | DWN H. HUANG 28JAN2013                 |              | TE Connectivity            |                           |
| mm          | 0 PLC ± | 1 PLC ±                                | 2 PLC ± | 3 PLC ±                                | 4 PLC ±      | 5 PLC ±                    | Harrisburg, PA 17105-3608 |
|             | ANGLES  | FINISH                                 |         | CHK S.XI 28JAN2013                     | NAME         | Ocean Side Feed Applicator |                           |
| MATERIAL    |         |  |         | APVD S.XI 28JAN2013                    | PRODUCT SPEC | RESTRICTED TO              |                           |
|             |         |  |         | APPLICATION SPEC                       | SIZE         | CAGE CODE                  | DRAWING NO                |
|             |         |  |         | WEIGHT                                 | A1           | 00779                      | ©=2151863                 |
|             |         |  |         | Customer Accessible Production Drawing | SCALE        | 1:2                        | SHEET 4 OF 4 REV F        |