

PART NUMBER	REVISION	DESCRIPTION	FEED TYPE
2266039-1	B	FINE CRIMP HEIGHT ADJUST	MECHANICAL
2266039-2	B	FINE CRIMP HEIGHT ADJUST	PNEUMATIC
7-2266039-1	B	MECHANICAL AND CRIMP TOOLING KIT	MECHANICAL
7-2266039-2	B	PNEUMATIC AND CRIMP TOOLING KIT	PNEUMATIC
7-2266039-7	A	CRIMP TOOLING KIT	-

ATLANTIC VERSION TERMINATOR INTERFACE ADAPTER

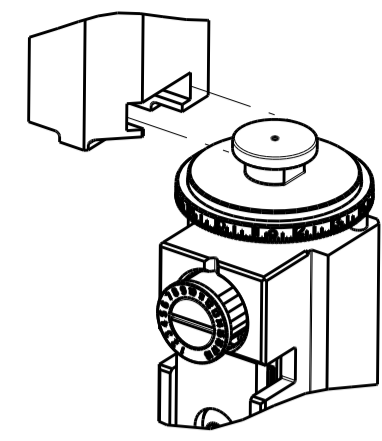

APPLICATOR DATA		
CRIMP	SIZE	TYPE
WIRE	2.54 mm [.100]	F
INSUL	4.06 mm [.160]	O

APPLICATOR INSTRUCTIONS  
408-35042

TERMINAL DATA: DELPHI TERMINAL TE CRIMP SPECIFICATION	
TERMINAL NAME: TEREMINAL	
WIRE STRIP LENGTH	TERMINAL INSULATION DIAMETER RANGE
4.05-4.07 mm [.160-.160 IN]	Ø2.20-2.80 mm [.087-.110 IN]
TERMINAL APPLICATION SPECIFICATION	TERMINAL INSULATION DIAMETER RANGE
NONE	-

TERMINALS APPLIED				
TE TERMINAL	DELPHI TERMINAL	TE SEAL	DELPHI SEAL	SEAL INSULATION DIAMETER RANGE
2113381-1	15344660	286867-2	15324973	2.0-2.9mm
2113381-2	15493061	286867-6	15327863	2.2-2.8mm
2113381-3	15427000	286867-7	15327859	2.2-2.8mm
2113381-4	13601173	286867-8	15339838	2.2-2.8mm
2113381-5	13601170			

WIRE SIZE	CRIMP HEIGHT mm [INCH]	CRIMP HEIGHT REFERENCE SETTING
2.50mm2	1.90 +/- 0.05 [.075 +/- .002]	5.5
2.00mm2	1.70 +/- 0.05 [.067 +/- .002]	7.6
1.50mm2	1.70 +/- 0.05 [.067 +/- .002]	7.9

- 1 RECOMMENDED SPARE PARTS
- 2 REFER TO SUPPLIED INSTRUCTION SHEET FOR CLEANING, LUBRICATION AND STORAGE OF APPLICATOR.
- 3 APPLY PART NUMBER 2-23419-6 LOCTITE TO THREADS OF ITEM 242.
- 4 CRIMP HEIGHT REFERENCE SETTING WAS THE SETTING USED WHEN THE APPLICATOR WAS QUALIFIED AT THE FACTORY. ADJUSTMENT MAY BE NECESSARY WHEN RUNNING APPLICATOR IN THE FIELD.
- 5 APPLY TORQ-SEAL IN ALLEN SOCKET TO FILL HOLE AFTER FLAT HD HAS BEEN ADJUSTED TO CORRECT HEIGHT AT QUALIFICATION. APPLY #1-23419-5 LOC-TITE TO THREADS.
- 6. UNLESS SPECIFIED OTHERWISE TORQUE VALUES SHALL BE USED PER DOCUMENT, 101-35000.

**\*WARNING**  
ON INSTALLATION, SET WIRE DISC TO CRIMP HEIGHT REFERENCE SETTING FOR LARGEST WIRE SIZE. CRIMP HEIGHT REFERENCE SETTINGS GREATER THAN THE VALUE SHOWN MAY CAUSE DAMAGE TO THE CRIMP TOOLING, REFER TO THE INSTRUCTION SHEET FOR PROPER SETUP AND ADJUSTMENTS

**ATLANTIC VERSION**  
Shown on sheets 1 of 4 & 2 of 4  
(Pacific version shown on sheets 3 of 4 & 4 of 4)

LOC	DIST	REVISIONS					
		P	LTN	DESCRIPTION	DATE	OWN	APVD
A	66	1		DEVELOPMENT	17SEP2013	YY	UG
		A		RELEASED	18OCT2013	YY	UG
		B		ECR-20-003824	13MAR2020	FZ	TE

-	1	-	1	-	2119641-1	FEED CAM, AIR FEED	248	
-	1	1	1	1	2119082-7	CAM, SNAIL, INSULATION ADJUSTMENT	244	
-	1	1	1	1	2079764-1	WASHER, WAVE SPRING, CREST-TO-CREST	243	
-	1	1	1	1	2119083-1	RETAINER, INSULATION DIAL	242	
-	1	1	1	1	7-18023-7	SCR, SKT HD CAP M3 X 4.0	241	
-	-	1	-	1	2119580-1	MECHANICAL FEED ASSEMBLY	239	
-	1	-	1	-	2844940-1	AIR FEED MODULE	238	
-	REF	REF	REF	REF	994970-2	COUNTER, MAGNETIC	164	
-	1	1	1	1	1-18028-2	WASHER, FLAT, REG M4	119	
-	1	1	1	1	2844908-1	SCREW, LOCKING	99	
-	1	1	1	1	2844907-1	POST, LOCKING	98	
-	1	1	1	1	455888-5	SPACER, CRIMPER	82	
-	1	1	1	1	1803607-3	DOCUMENTATION PACKAGE	71	
-	1	1	1	1	2119740-1	TAG, IDENTIFICATION	67	
-	2	2	2	2	2168078-1	SCREW, DRIVE, RH, RoHS, 2 x .188	66	
-	1	1	1	1	2168083-2	SCR, SKT HD CAP, RoHS, M4 X 8.0	60	
-	1	1	1	1	5-18022-5	SCR, HEX HD CAP, M4 X 6.0	59	
-	1	1	1	1	985575-3	SCR, FLT SKT HD CAP M3 X 10.0	57	
-	1	1	1	1	1338685-1	PAWL, FEED	56	
-	4	4	4	4	2168083-3	SCR, SKT HD CAP, RoHS, M4 X 12.0	54	
-	2	2	2	2	1-2168083-0	SCR, SKT HD CAP, RoHS, M4 X 10	53	
-	1	1	1	1	1803382-6	HOLD DOWN, SPRING LOADED	50	
-	1	2	1	2	18023-9	SCR, SKT HD CAP M4 X 6.0	49	
-	-	1	-	1	2119652-1	FEED CAM, PRE FEED	48	
-	-	1	-	1	2119653-1	FEED CAM, POST FEED	47	
-	1	1	1	1	1803583-9	APPLICATOR BASIC ASSEMBLY, SF	46	
-	1	1	1	1	1803515-1	RAM ASSEMBLY, SF ATLANTIC	44	
-	1	1	1	1	1803602-1	SCR, BHSC, RoHS (M8 X 25)	41	
-	1	1	1	1	1752356-4	SUPPORT, TERMINAL	34	
-	2	2	2	2	2079383-5	SCR, BHSC, RoHS (M4 X 20)	33	
-	2	2	2	2	2-2844962-8	SPACER, CYLINDRICAL, STRIP GUIDE	30	
-	1	1	1	1	2844992-4	ASSEMBLY, STRIP GUIDE	29	
-	1	1	1	1	455888-3	SPACER, CRIMPER	28	
-	1	1	1	1	1320928-2	STRIP GUIDE	24	
-	1	1	1	1	240792-5	DRAG, TERMINAL	23	
-	1	1	1	1	2168083-2	SCR, SKT HD CAP, RoHS, M4 X 8.0	21	
-	1	1	1	1	1-18028-2	WASHER, FLAT, REG M4	20	
-	1	1	1	1	2119533-1	STRIPPER, SIDE FEED	19	
-	1	1	1	1	2119806-1	INSERT, SHEAR	13	
-	1	1	1	1	3-22280-3	SPRING, COMPRESSION	12	
-	1	1	1	1	1-356885-4	STOP, SHEAR	11	
-	1	1	1	1	2119805-1	SHEAR HOLDER, FRONT	10	
-	1	1	1	1	318707-1	FLOATING SHEAR, FRONT	9	
-	1	2	2	1	1-1633922-6	ANVIL, COMBINATION	8	
-	-	-	-	-	-	-	7	
-	-	-	-	-	-	-	6	
-	1	1	1	1	2119781-1	DEPRESSOR, SHEAR	5	
-	1	1	1	1	238011-9	BLOCK, CRIMPER SPACER	4	
-	1	2	2	1	3-2119784-1	CRIMPER, INSULATION O PREMIUM	3	
-	1	1	1	1	455888-3	SPACER, CRIMPER	2	
-	1	2	2	1	1-456407-4	CRIMPER, WIRE PREMIUM	1	
-	77	72	71	2	-1	PART NO	DESCRIPTION	ITEM NO

DIMENSIONS:		TOLERANCES UNLESS OTHERWISE SPECIFIED:		OWN: Y. YIN 17SEP2013		CHK: G. BAILEY 17SEP2013		APVD: H. GUO 17SEP2013		NAME: Ocean Side Feed Applicator	
mm		0 PLC ±		SIZE: A1		CAGE CODE: 00779		DRAWING NO: 2266039		RESTRICTED TO: B	
MATERIAL:		FINISH:		WEIGHT:		SCALE: 1:2		SHEET: 1 OF 4		REV: B	

LOC	DIST	REVISIONS					
A	66	P	LTN	DESCRIPTION	DATE	DWN	APVD
		-		SEE SHEET 1	-	-	-

# FEED TYPE MECHANICAL

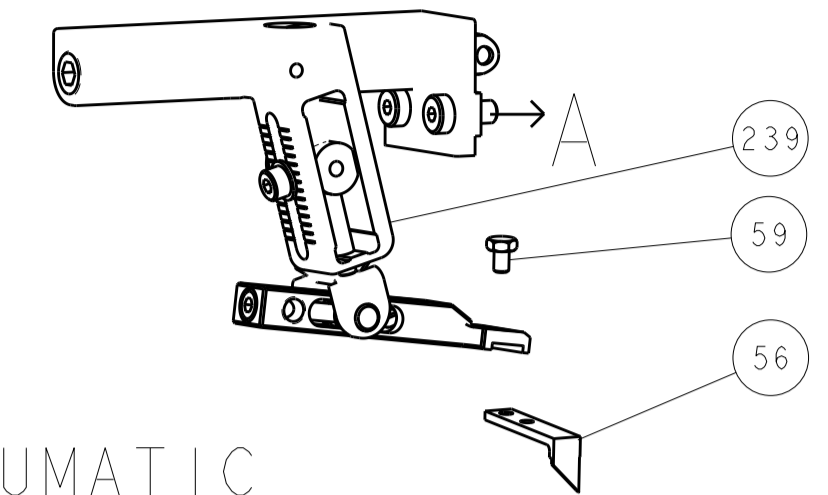

## PNEUMATIC

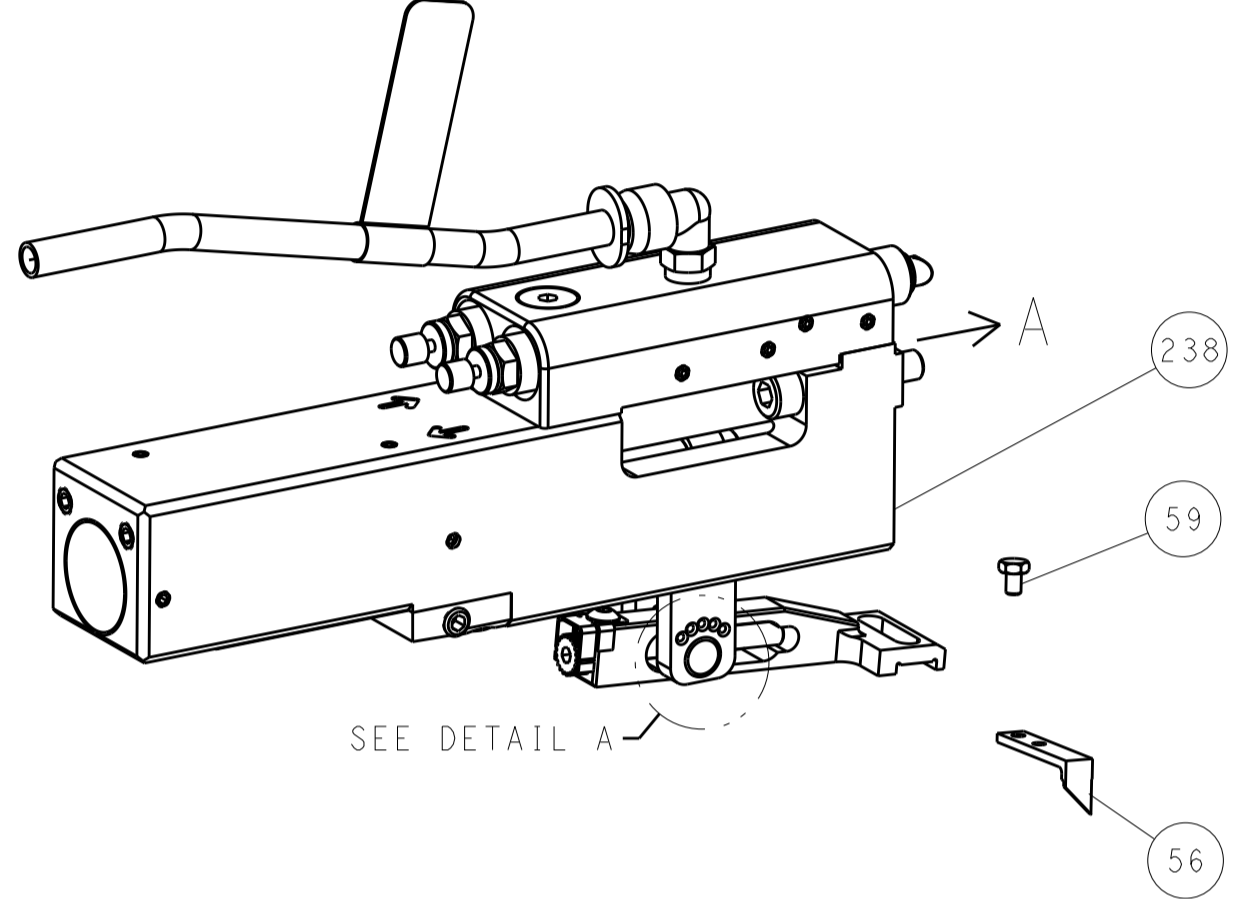

## FEED SPRING SETTING POSITION (SHOWN FROM REAR SIDE)

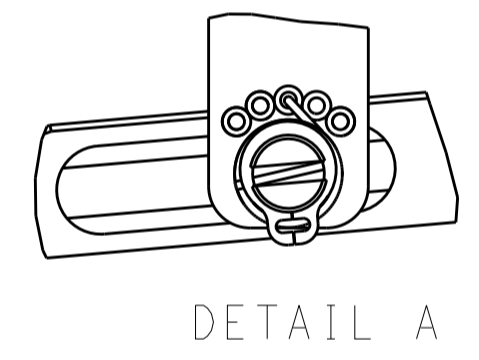

DETAIL A

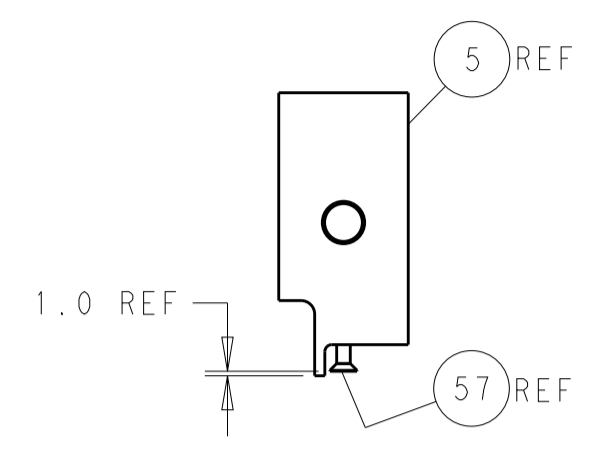
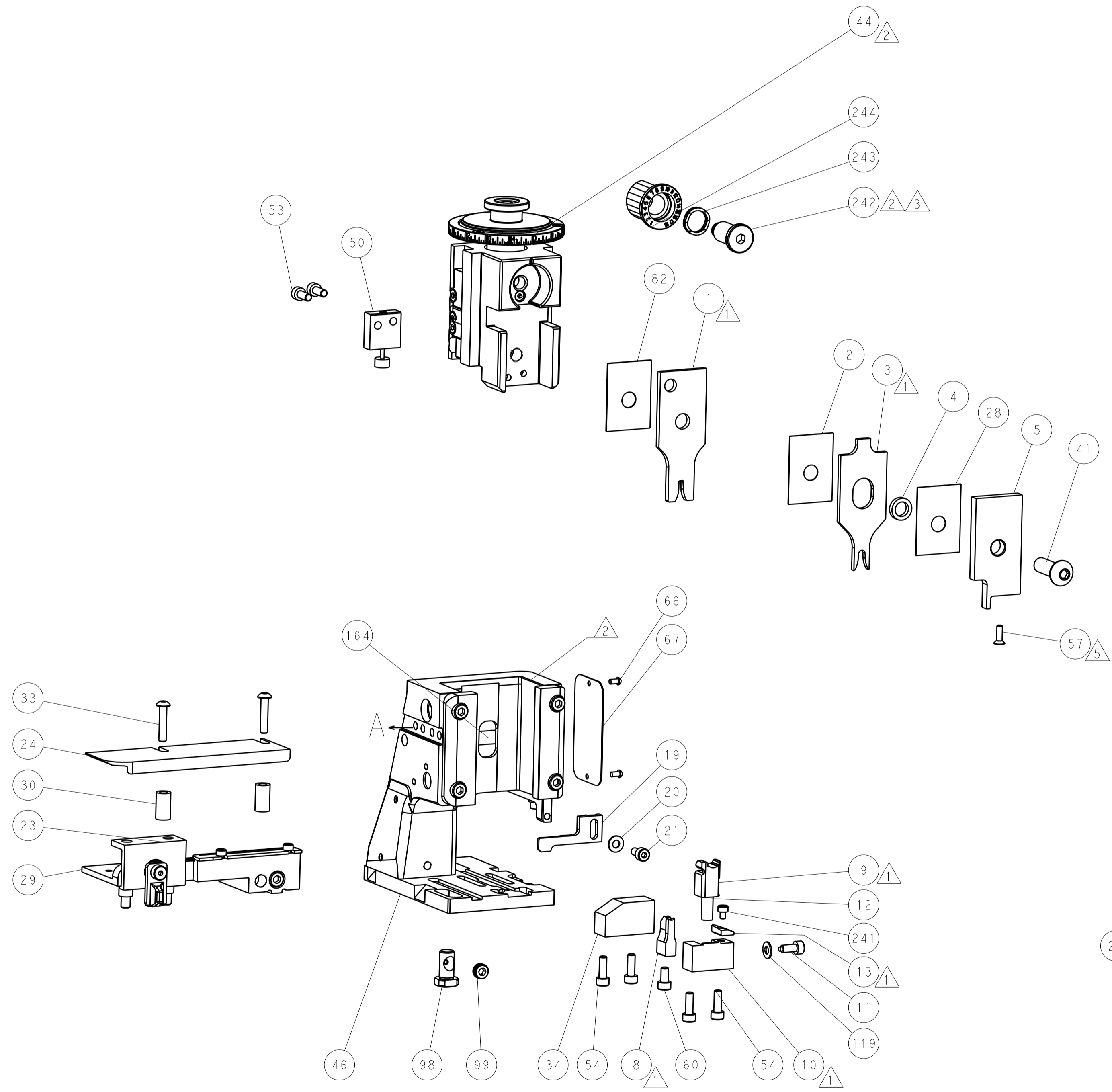

SHEAR DEPRESSOR DETAIL

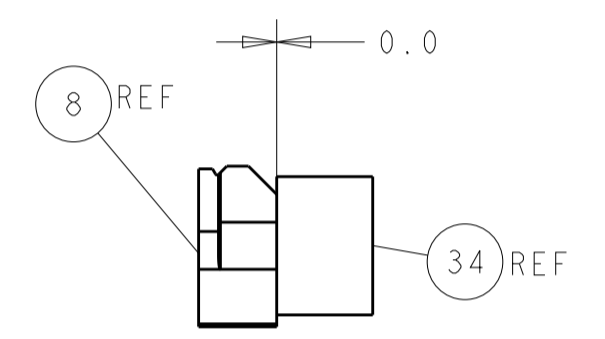

TERMINAL SUPPORT LOCATION

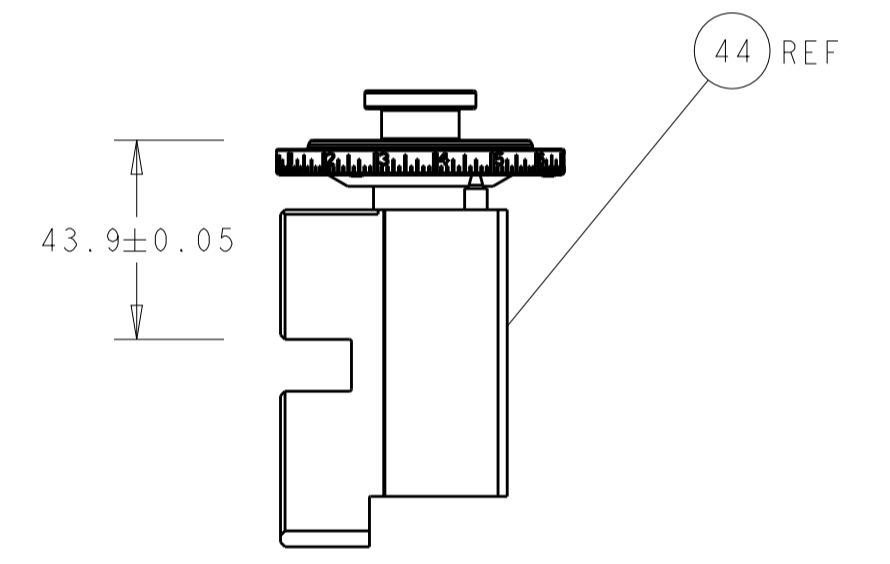

RAM SET-UP

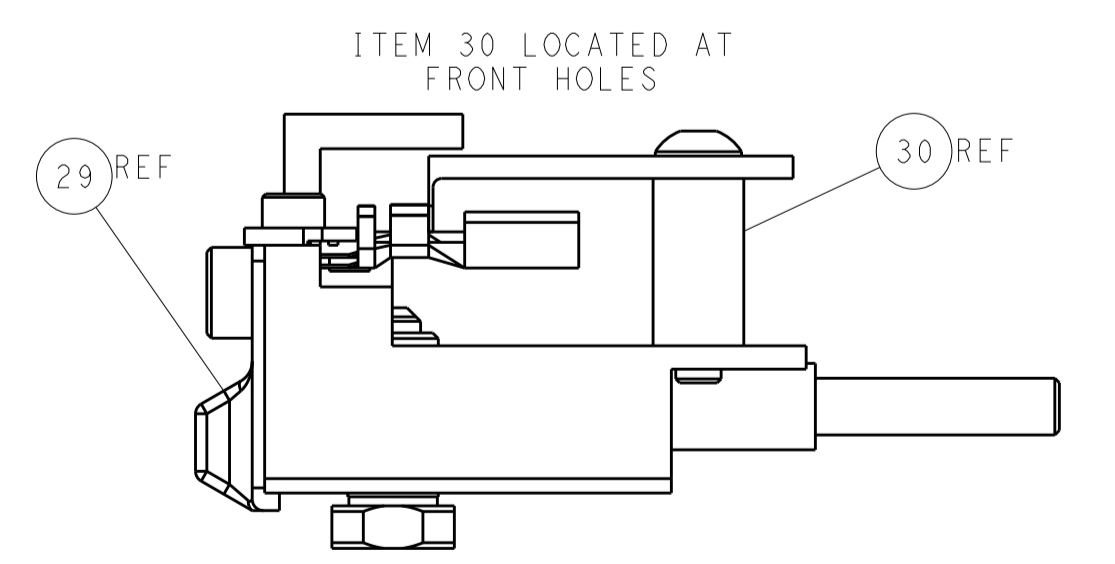

FEED TRACK POSITION GUIDE BY WIRE BARREL

# CAM POSITIONS

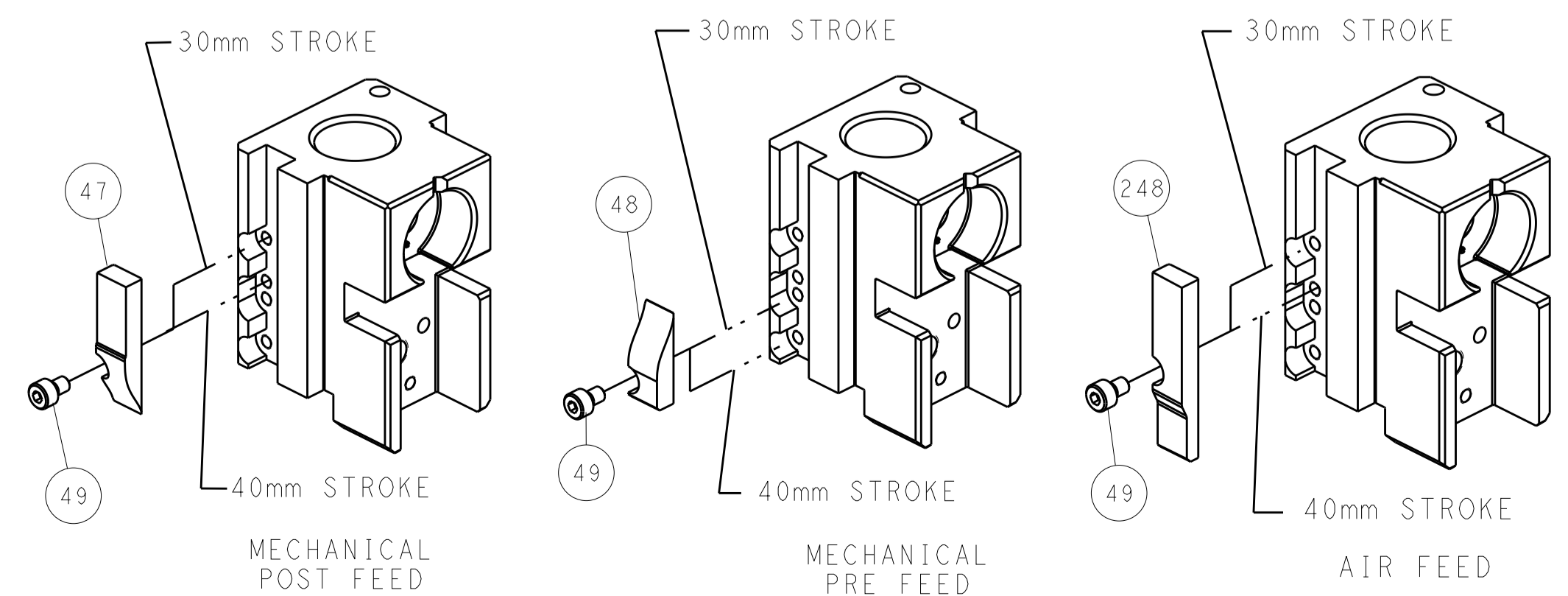

**ATLANTIC VERSION**  
 Shown on sheets 1 of 4 & 2 of 4  
 (Pacific version shown on sheets 3 of 4 & 4 of 4)

DIMENSIONS:		TOLERANCES UNLESS OTHERWISE SPECIFIED:		DWN: Y. YIN 17SEP2013		TE Connectivity	
mm	0 PLC ±	1 PLC ±	2 PLC ±	3 PLC ±	4 PLC ±	Harrisburg, PA 17105-3608	
MATERIAL:		FINISH:		CHK: G. BAILEY 17SEP2013		NAME: Ocean Side Feed Applicator	
				APVD: H. GUO 17SEP2013		PRODUCT SPEC:	
						APPLICATION SPEC:	
				WEIGHT:		SIZE: CAGE CODE: DRAWING NO:	
				Customer Accessible Production Drawing		A1 00779 ©=2266039	
				SCALE: 1:2		SHEET 2 OF 4 REV B	

PART NUMBER	REVISION	DESCRIPTION	FEED TYPE
2-2266039-1	B	FINE CRIMP HEIGHT ADJUST	MECHANICAL
2-2266039-2	B	FINE CRIMP HEIGHT ADJUST	PNEUMATIC
7-2266039-7	A	CRIMP TOOLING KIT	-

PACIFIC VERSION TERMINATOR  
 INTERFACE ADAPTER



APPLICATOR DATA		
CRIMP	SIZE	TYPE
WIRE	2.54 mm [.100]	F
INSUL	4.06 mm [.160]	O

APPLICATOR INSTRUCTIONS  
 408-35042

TERMINAL DATA: DELPHI TERMINAL		TE CRIMP SPECIFICATION	
TERMINAL NAME: TEREMINAL			
WIRE STRIP LENGTH 4.05-4.07 mm [.160-.160 IN]		TERMINAL INSULATION DIAMETER RANGE Ø2.20-2.80 mm [.087-.110 IN]	
TERMINAL APPLICATION SPECIFICATION NONE			

TERMINALS APPLIED				SEAL INSULATION DIAMETER RANGE
TE TERMINAL	DELPHI TERMINAL	TE SEAL	DELPHI SEAL	
2113381-1	15344660	286867-2	15324973	2.0-2.9mm
2113381-2	15493061	286867-6	15327863	2.2-2.8mm
2113381-3	15427000	286867-7	15327859	2.2-2.8mm
2113381-4	13601173	286867-8	15339838	2.2-2.8mm
2113381-5	13601170			

WIRE SIZE	CRIMP HEIGHT mm [INCH]	CRIMP HEIGHT REFERENCE SETTING
2.50mm2	1.90+/-0.05 [.075+/-0.002]	5.5
2.00mm2	1.70+/-0.05 [.067+/-0.002]	7.6
1.50mm2	1.70+/-0.05 [.067+/-0.002]	7.9

- 1 RECOMMENDED SPARE PARTS
- 2 REFER TO SUPPLIED INSTRUCTION SHEET FOR CLEANING, LUBRICATION AND STORAGE OF APPLICATOR.
- 3 APPLY PART NUMBER 2-23419-6 LOCTITE TO THREADS OF ITEM 242.
- 4 CRIMP HEIGHT REFERENCE SETTING WAS THE SETTING USED WHEN THE APPLICATOR WAS QUALIFIED AT THE FACTORY. ADJUSTMENT MAY BE NECESSARY WHEN RUNNING APPLICATOR IN THE FIELD.
- 5 APPLY TORO-SEAL IN ALLEN SOCKET TO FILL HOLE AFTER FLAT HD HAS BEEN ADJUSTED TO CORRECT HEIGHT AT QUALIFICATION. APPLY #1-23419-5 LOC-TITE TO THREADS.
- 6. UNLESS SPECIFIED OTHERWISE TORQUE VALUES SHALL BE USED PER DOCUMENT, 101-35000.

**\*WARNING**  
 ON INSTALLATION, SET WIRE DISC TO CRIMP HEIGHT REFERENCE SETTING FOR LARGEST WIRE SIZE. CRIMP HEIGHT REFERENCE SETTINGS GREATER THAN THE VALUE SHOWN MAY CAUSE DAMAGE TO THE CRIMP TOOLING, REFER TO THE INSTRUCTION SHEET FOR PROPER SETUP AND ADJUSTMENTS

PACIFIC VERSION  
 Shown on sheets 3 of 4 & 4 of 4  
 (Atlantic version shown on sheets 1 of 4 & 2 of 4)

LOC	DIST	REV	DATE	BY	APPD
A	66				

REVISIONS					
REV	DATE	DESCRIPTION	DATE	BY	APPD
-	-	SEE SHEET 1	-	-	-
-	1	1	2119082-7	CAM, SNAIL, INSULATION ADJUSTMENT	244
-	1	1	2079764-1	WASHER, WAVE SPRING, CREST-TO-CREST	243
3	-	1	2119083-1	RETAINER, INSULATION DIAL	242
-	1	1	7-18023-7	SCR, SKT HD CAP M3 X 4.0	241
-	-	1	2119580-1	MECHANICAL FEED ASSEMBLY	239
-	1	-	2844940-1	AIR FEED MODULE	238
-	REF	REF	994970-2	COUNTER, MAGNETIC	164
-	1	-	2119641-2	FEED CAM, AIR FEED	151
-	1	1	2168083-8	SCR, SKT HD CAP, RoHS, M4 X 16	144
-	4	4	2168083-9	SCR, SKT HD CAP, RoHS, M4 X 20	143
-	-	1	2119653-2	FEED CAM, POST FEED	142
-	1	1	1-1803583-0	APPLICATOR BASIC ASSEMBLY, SF	141
-	1	1	1803516-1	RAM ASSEMBLY, SF PACIFIC	140
-	1	1	1-18028-2	WASHER, FLAT, REG M4	119
-	1	1	2844908-1	SCREW, LOCKING	99
-	1	1	2844907-1	POST, LOCKING	98
-	1	1	455888-5	SPACER, CRIMPER	82
-	1	1	1803607-3	DOCUMENTATION PACKAGE	71
-	1	1	2119740-1	TAG, IDENTIFICATION	67
-	2	2	2168078-1	SCREW, DRIVE, RH, RoHS, 2 x .188	66
-	1	1	5-18022-5	SCR, HEX HD CAP, M4 X 6.0	59
5	-	1	985575-3	SCR, FLT SKT HD CAP M3 X 10.0	57
-	1	1	1338685-1	PAWL, FEED	56
-	2	2	1-2168083-0	SCR, SKT HD CAP, RoHS, M4 X 10	53
-	1	1	1803382-6	HOLD DOWN, SPRING LOADED	50
-	1	2	18023-9	SCR, SKT HD CAP M4 X 6.0	49
-	-	1	2119652-1	FEED CAM, PRE FEED	48
-	1	1	1803602-1	SCR, BHSC, RoHS (M8 X 25)	41
-	1	1	1752356-4	SUPPORT, TERMINAL	34
-	2	2	2079383-5	SCR, BHSC, RoHS (M4 X 20)	33
-	2	2	2-2844962-8	SPACER, CYLINDRICAL, STRIP GUIDE	30
-	1	1	2844992-4	ASSEMBLY, STRIP GUIDE	29
-	1	1	455888-3	SPACER, CRIMPER	28
-	1	1	1320928-2	STRIP GUIDE	24
-	1	1	240792-5	DRAG, TERMINAL	23
-	1	1	2168083-2	SCR, SKT HD CAP, RoHS, M4 X 8.0	21
-	1	1	1-18028-2	WASHER, FLAT, REG M4	20
-	1	1	2119533-1	STRIPPER, SIDE FEED	19
1	-	1	2119806-1	INSERT, SHEAR	13
-	1	1	3-22280-3	SPRING, COMPRESSION	12
-	1	1	1-356885-4	STOP, SHEAR	11
1	-	1	2119805-1	SHEAR HOLDER, FRONT	10
1	-	1	318707-1	FLOATING SHEAR, FRONT	9
1	1	1	1-1633922-6	ANVIL, COMBINATION	8
-	-	-	-	-	7
-	-	-	-	-	6
-	1	1	2119781-1	DEPRESSOR, SHEAR	5
-	1	1	238011-9	BLOCK, CRIMPER SPACER	4
1	1	1	3-2119784-1	CRIMPER, INSULATION O PREMIUM	3
-	1	1	455888-3	SPACER, CRIMPER	2
1	1	1	1-456407-4	CRIMPER, WIRE PREMIUM	1

DIMENSIONS:		TOLERANCES UNLESS OTHERWISE SPECIFIED:		MATERIAL:		FINISH:	
mm	0 PLC ±	1 PLC ±	2 PLC ±	3 PLC ±	4 PLC ±	ANGLES ±	FINISH

DATE	17SEP2013	CHK	G. BAILEY	DATE	17SEP2013
APPD	J. GUO	DATE	17SEP2013	NAME	
PRODUCT SPEC		APPLICATION SPEC		SIZE	A1
WEIGHT		SCALE	1:2	SHEET	3 of 4
Customer Accessible Production Drawing		REV	B		

LOC	DIST	REVISIONS				
A	66	P. LTH	DESCRIPTION	DATE	DWN	APVD
		-	SEE SHEET 1	-	-	-

# FEED TYPE MECHANICAL

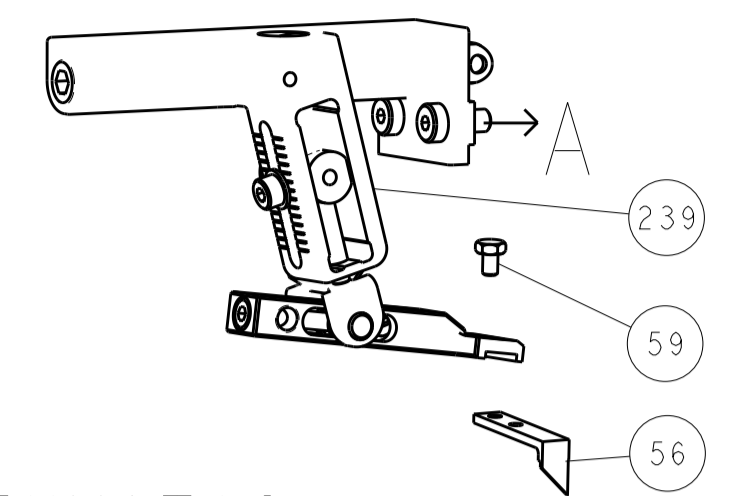

## PNEUMATIC

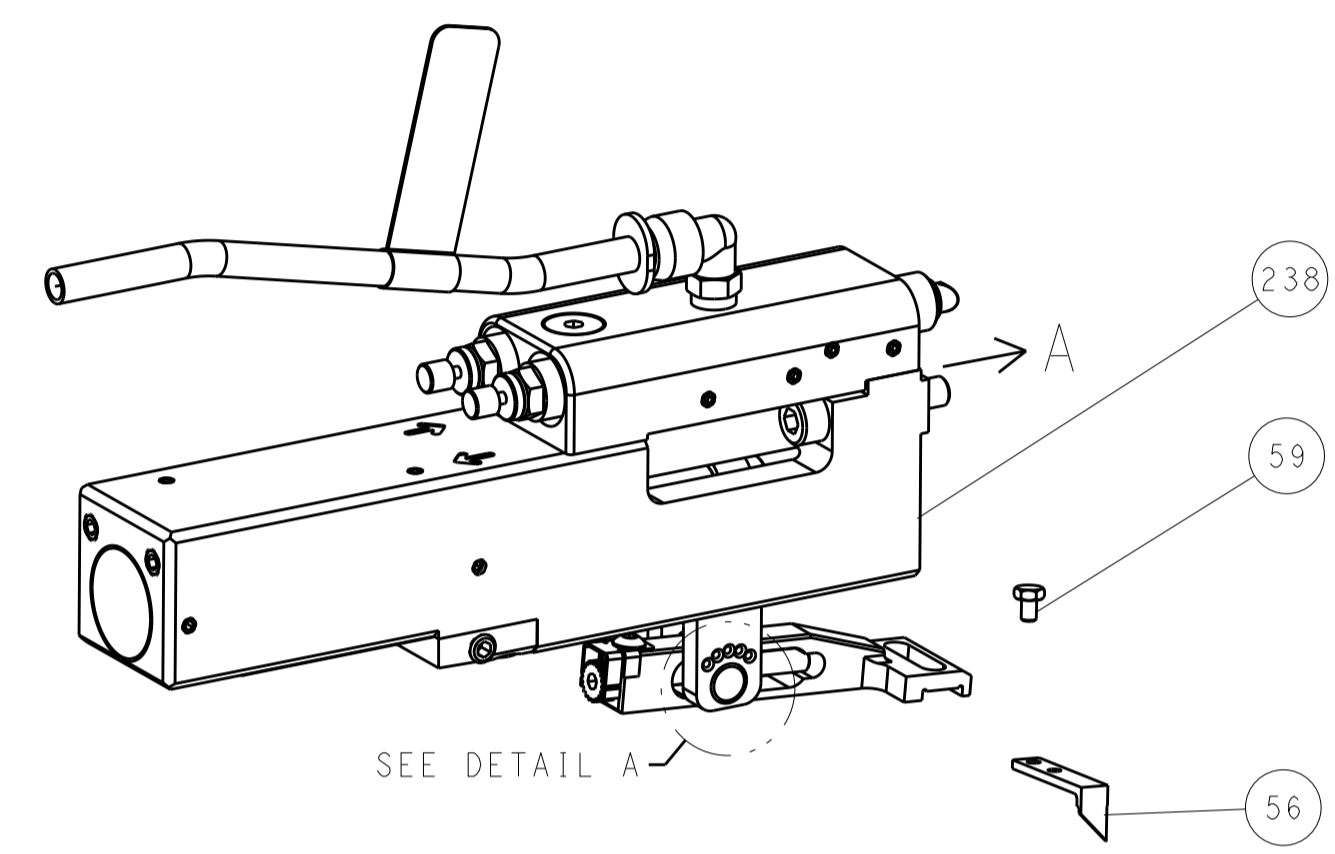

## FEED SPRING SETTING POSITION (SHOWN FROM REAR SIDE)

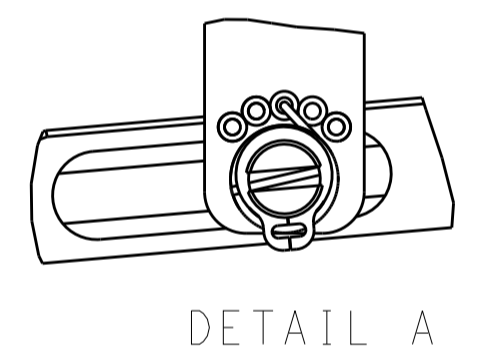

# CAM POSITIONS

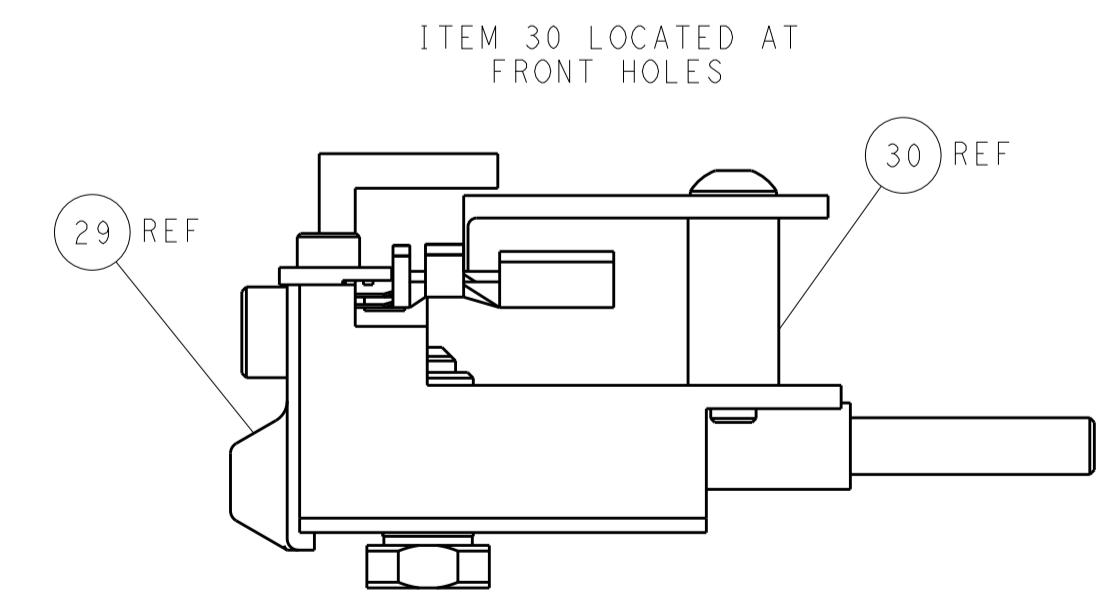
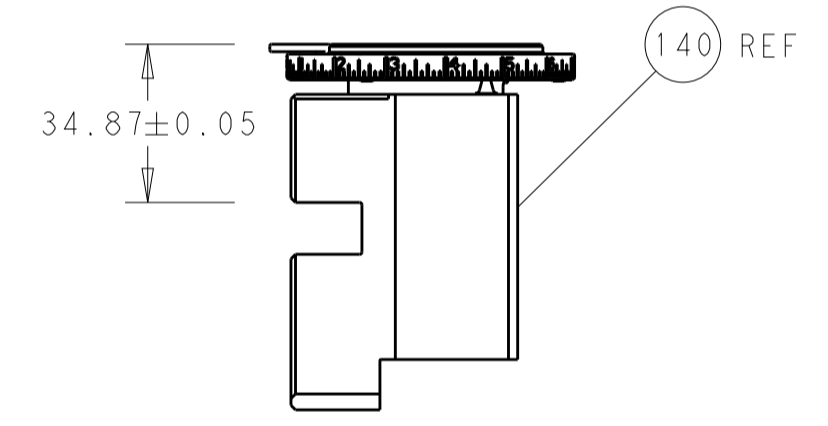
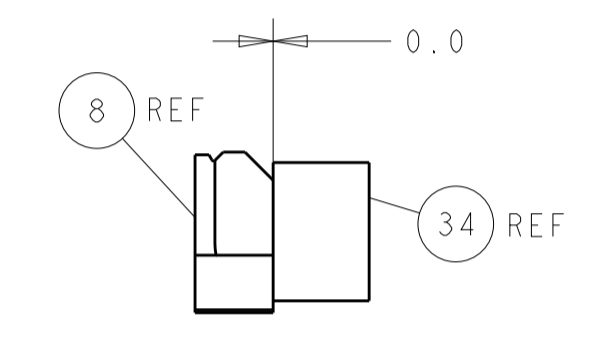
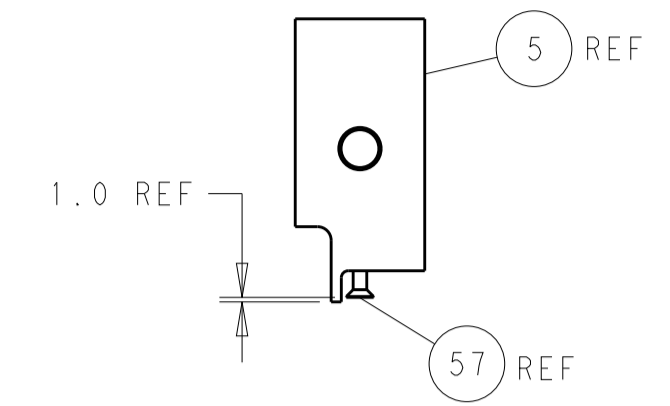
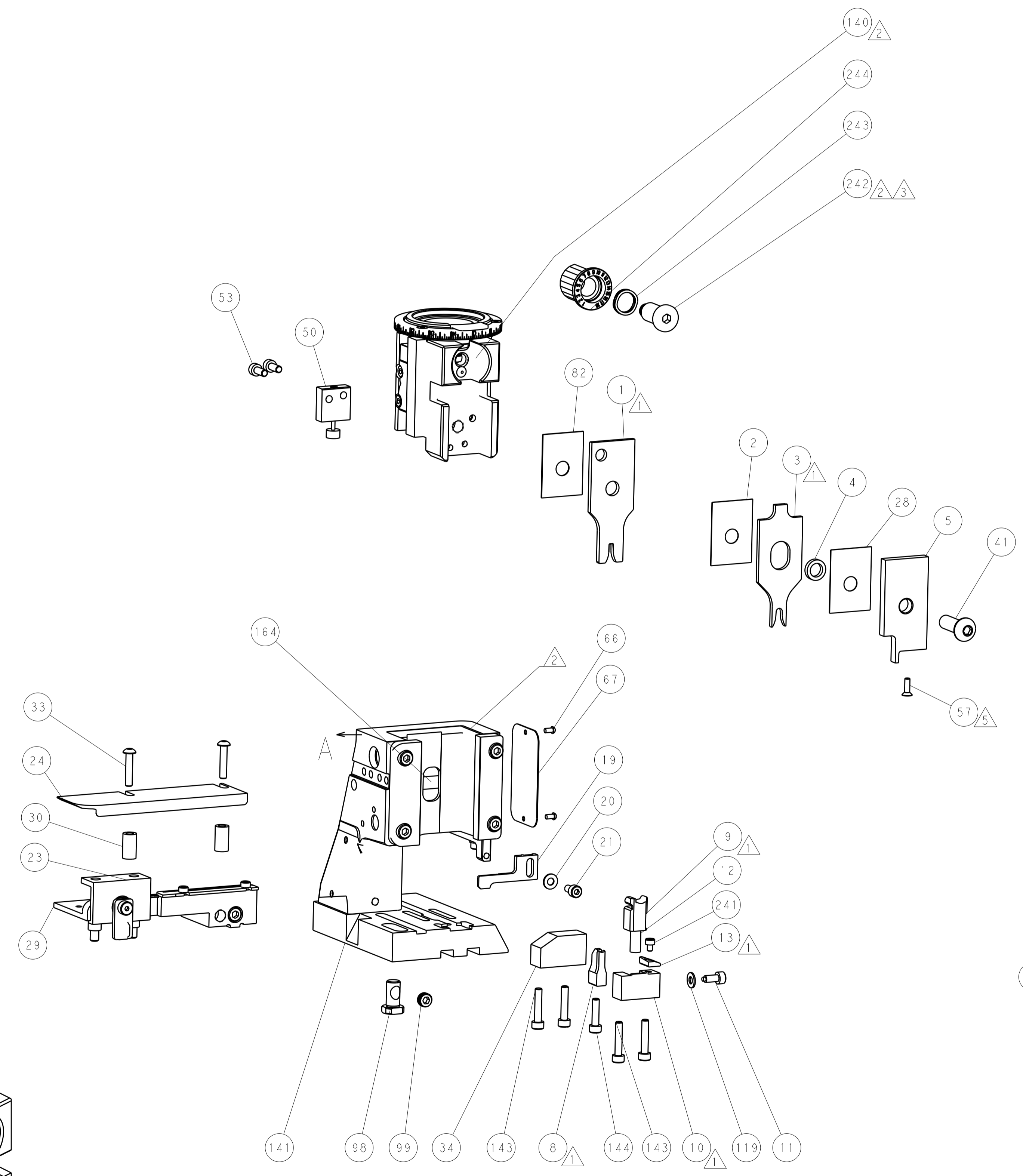
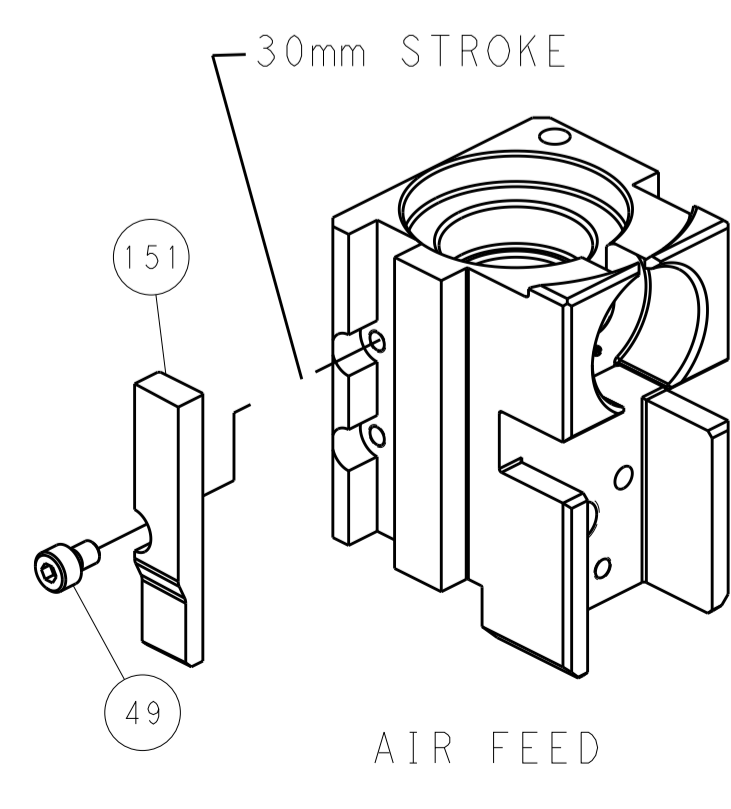
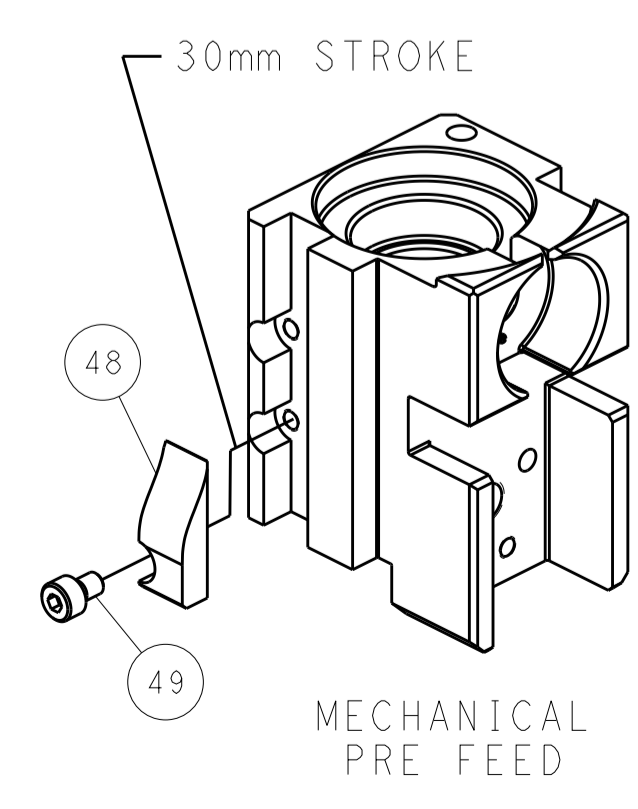
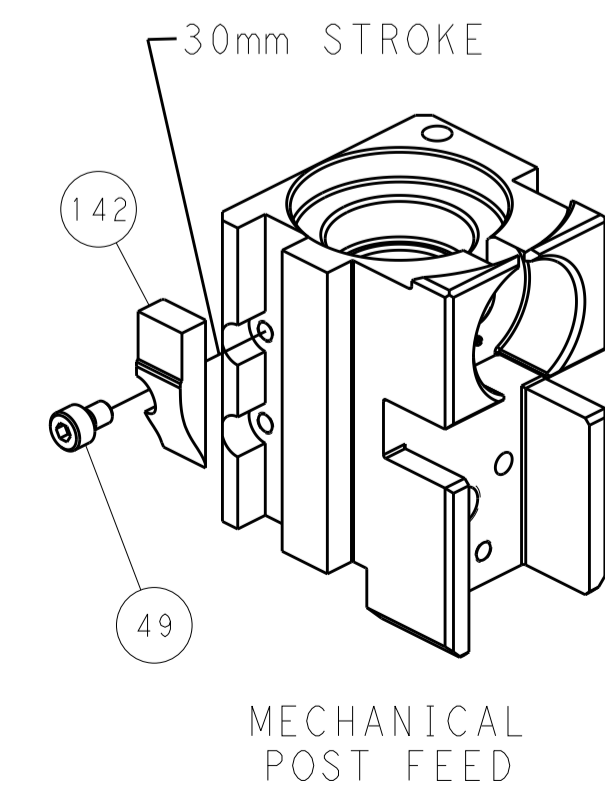

**PACIFIC VERSION**  
 Shown on sheets 3 of 4 & 4 of 4  
 (Atlantic version shown on sheets 1 of 4 & 2 of 4)

DIMENSIONS:		TOLERANCES UNLESS OTHERWISE SPECIFIED:		DWN Y. YIN 17SEP2013		TE Connectivity	
mm	0 PLC ±	1 PLC ±	2 PLC ±	3 PLC ±	4 PLC ±	Harrisburg, PA 17105-3608	
MATERIAL:		FINISH:		APVD G. BAILEY 17SEP2013		NAME	
				PRODUCT SPEC		Ocean Side Feed	
				APPLICATION SPEC		Applicator	
				WEIGHT		SIZE CAGE CODE DRAWING NO	
				Customer Accessible Production Drawing		A 00779 C=2266039	
				SCALE		RESTRICTED TO	
				1:2		SHEET 4 OF 4 REV B	