

PART NUMBER	REVISION	DESCRIPTION	FEED TYPE
2266126-1	D	FINE CRIMP HEIGHT ADJUST	MECHANICAL
2266126-2	E	FINE CRIMP HEIGHT ADJUST	PNEUMATIC
7-2266126-1	D	MECHANICAL AND CRIMP TOOLING KIT	MECHANICAL
7-2266126-2	E	PNEUMATIC AND CRIMP TOOLING KIT	PNEUMATIC
7-2266126-7	B	CRIMP TOOLING KIT	-
7-2266126-8	B	APPLICATOR CONVERSION KIT	-

ATLANTIC VERSION TERMINATOR INTERFACE ADAPTER

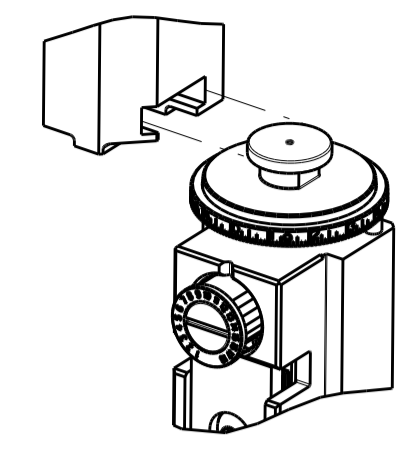

APPLICATOR DATA

CRIMP	SIZE	TYPE
WIRE	2.97 mm [.117]	F
INSUL	2.90 mm [.114]	O

APPLICATOR INSTRUCTIONS 408-35042

APPLICATOR CONVERSION KITS

PART NUMBER	INSULATION DIAMETER RANGE
7-2266124-8	∅ 3.83-4.47mm [.151-.176]
7-2266125-8	∅ 3.27-3.81mm [.129-.150]
7-2266126-8	∅ 2.87-3.25mm [.113-.128]

TERMINAL DATA: DEUTSCH TERMINAL DEUTSCH CRIMP SPECIFICATION

TERMINAL NAME: STAMPED CONTACT PIN SIZE 12

WIRE STRIP LENGTH	INSULATION DIAMETER RANGE
5.71-6.99 mm [.225-.275 IN]	∅ 2.87-3.43 mm [.113-.135 IN]

TERMINAL APPLICATION SPECIFICATION 114-151002

TERMINALS APPLIED 5, 7

TE TERMINAL	DEUTSCH TERMINAL	TE TERMINAL	DEUTSCH TERMINAL
1572028-2	1060-12-0144	1572028-1	1060-12-0166

TERMINAL DATA: DEUTSCH TERMINAL DEUTSCH CRIMP SPECIFICATION

TERMINAL NAME: STAMPED CONTACT SOCKET SIZE 12

WIRE STRIP LENGTH	INSULATION DIAMETER RANGE
5.71-6.99 mm [.225-.275 IN]	∅ 2.87-3.43 mm [.113-.135 IN]

TERMINAL APPLICATION SPECIFICATION 114-151002

TERMINALS APPLIED 5, 8

TE TERMINAL	DEUTSCH TERMINAL	TE TERMINAL	DEUTSCH TERMINAL
286955-2	1062-12-0144	286955-1	1062-12-0166

WIRE SIZE	CRIMP HEIGHT mm [INCH]	CRIMP HEIGHT REFERENCE SETTING
4.00mm2	2.24+0.03/-0.05 [.088+.001/- .002]	4.9
12 AWG	2.03+0.03/-0.05 [.080+.001/- .002]	7.2
3.00mm2	2.03+0.03/-0.05 [.080+.001/- .002]	7.4
2.50mm2	1.88+0.03/-0.05 [.074+.001/- .002]	8.3
14 AWG	1.78+0.03/-0.05 [.070+.001/- .002]	9.7
2.00mm2	1.78+0.03/-0.05 [.070+.001/- .002]	9.7

- 1 RECOMMENDED SPARE PARTS
- 2 REFER TO SUPPLIED INSTRUCTION SHEET FOR CLEANING, LUBRICATION AND STORAGE OF APPLICATOR.
- 3 APPLY PART NUMBER 2-23419-6 LOCTITE TO THREADS OF ITEM 242.
- 4 CRIMP HEIGHT REFERENCE SETTING WAS THE SETTING USED WHEN THE APPLICATOR WAS QUALIFIED AT THE FACTORY. ADJUSTMENT MAY BE NECESSARY WHEN RUNNING APPLICATOR IN THE FIELD.
- 5 TERMINAL LUBRICANT IS RECOMMENDED.
- 6. UNLESS SPECIFIED OTHERWISE TORQUE VALUES SHALL BE USED PER DOCUMENT, 101-35000.
- 7 DIMENSION 2.0±0.50 APPLIES TO PIN TERMINALS 1060-12-01XX.
- 8 DIMENSION 7.92±0.50 APPLIES TO SOCKET TERMINALS 1062-12-01XX.
- 9 SEE APPROPRIATE APPLICATOR LOG SHEETS FOR APPLIED TERMINALS AND WIRE RANGE.

***WARNING**
 ON INSTALLATION, SET WIRE DISC TO CRIMP HEIGHT REFERENCE SETTING FOR LARGEST WIRE SIZE. CRIMP HEIGHT REFERENCE SETTINGS GREATER THAN THE VALUE SHOWN MAY CAUSE DAMAGE TO THE CRIMP TOOLING. REFER TO THE INSTRUCTION SHEET FOR PROPER SETUP AND ADJUSTMENTS.

LOC	DIST	REV	DATE	BY	CHK
A	66	B3	22SEP2017	FL	GB
		C	07MAY2018	TB	JDG
		D	14MAR2019	RK	GB
		E	11JUL2019	FJ	TE

-	-	1	-	1	-	2119641-1	FEED CAM, AIR FEED	248
-	-	1	1	1	1	2119082-9	CAM, SNAIL, INSULATION ADJUSTMENT	244
-	-	1	1	1	1	2079764-1	WASHER, WAVE SPRING, CREST-TO-CREST	243
-	-	1	1	1	1	2119083-1	RETAINER, INSULATION DIAL	242
-	-	1	1	1	1	7-18023-7	SCR, SKT HD CAP M3 X 4.0	241
-	-	-	1	-	1	2119580-1	MECHANICAL FEED ASSEMBLY	239
-	-	1	-	1	-	2844940-1	AIR FEED MODULE	238
-	-	REF	REF	REF	REF	994970-2	COUNTER, MAGNETIC	164
-	-	1	1	1	1	1-18028-2	WASHER, FLAT, REG M4	119
-	-	1	1	1	1	2119955-1	ASSY, LUBRICATOR, SIDE FEED	113
-	-	1	1	1	1	2844908-1	SCREW, LOCKING	99
-	-	1	1	1	1	2844907-1	POST, LOCKING	98
-	-	1	1	1	1	455888-5	SPACER, CRIMPER	82
-	-	1	1	1	1	2119791-9	DEPRESSOR, WIRE	78
1	-	-	-	-	-	2266126	PRINT, APPLICATOR LOG SHEET	72
-	-	1	1	1	1	1803607-3	DOCUMENTATION PACKAGE	71
-	-	1	1	1	1	2119791-9	DEPRESSOR, WIRE	70
-	-	1	1	1	1	2119740-1	TAG, IDENTIFICATION	67
-	-	2	2	2	2	2168078-1	SCREW, DRIVE, RH, RoHS, 2 x .188	66
-	-	1	1	1	1	2168083-2	SCR, SKT HD CAP, RoHS, M4 X 8.0	60
-	-	1	1	1	1	5-18022-5	SCR, HEX HD CAP, M4 X 6.0	59
-	-	1	1	1	1	1338685-1	PAWL, FEED	56
-	-	4	4	4	4	2168083-3	SCR, SKT HD CAP, RoHS, M4 X 12.0	54
2	-	2	2	2	2	2168083-3	SCR, SKT HD CAP, RoHS, M4 X 12.0	53
-	-	1	1	1	1	5018030-1	NUT, HEX, REG, RoHS, M3	52
-	-	1	1	1	1	811242-5	BUMPER, HOLD DOWN	51
-	-	1	1	1	1	690753-2	SPACER, TONKER	50
-	-	1	2	1	2	18023-9	SCR, SKT HD CAP M4 X 6.0	49
-	-	-	1	-	1	2119652-1	FEED CAM, PRE FEED	48
-	-	-	1	-	1	2119653-1	FEED CAM, POST FEED	47
-	-	1	1	1	1	1803583-9	APPLICATOR BASIC ASSEMBLY, SF	46
-	-	1	1	1	1	1803515-1	RAM ASSEMBLY, SF ATLANTIC	44
-	-	1	1	1	1	1803602-1	SCR, BHSC, RoHS (M8 X 25)	41
-	-	1	1	1	1	1752356-6	SUPPORT, TERMINAL	34
-	-	2	2	2	2	2079383-5	SCR, BHSC, RoHS (M4 X 20)	33
-	-	2	2	2	2	2-2844962-8	SPACER, CYLINDRICAL, STRIP GUIDE	30
-	-	1	1	1	1	2844992-1	ASSEMBLY, STRIP GUIDE	29
-	-	1	1	1	1	1320928-6	STRIP GUIDE	24
-	-	1	1	1	1	2168083-2	SCR, SKT HD CAP, RoHS, M4 X 8.0	21
-	-	1	1	1	1	1-18028-2	WASHER, FLAT, REG M4	20
-	-	1	1	1	1	2119533-1	STRIPPER, SIDE FEED	19
-	-	1	1	1	1	2119806-1	INSERT, SHEAR	13
-	-	1	1	1	1	3-22280-3	SPRING, COMPRESSION	12
-	-	1	1	1	1	1-356885-4	STOP, SHEAR	11
-	-	1	1	1	1	2119805-1	SHEAR HOLDER, FRONT	10
-	-	1	1	1	1	1803095-1	FLOATING SHEAR, FRONT	9
1	1	2	2	1	1	2-1803293-2	ANVIL, COMBINATION DEUTSCH STYLE	8
-	-	1	1	1	1	3-240641-7	SPACER	7
-	-	-	-	-	-	-	-	6
1	-	1	1	1	1	2119757-8	DEPRESSOR, SHEAR	5
-	-	1	1	1	1	238011-2	BLOCK, CRIMPER SPACER	4
1	1	2	2	1	1	2-1803019-8	CRIMPER, INSULATION O	3
-	-	1	1	1	1	455888-4	SPACER, CRIMPER	2
1	-	1	2	2	1	4-1633713-6	CRIMPER, WIRE PREMIUM	1

ATLANTIC VERSION
 Shown on sheets 1 of 4 & 2 of 4
 (Pacific version shown on sheets 3 of 4 & 4 of 4)

DIMENSIONS: mm 		TOLERANCES UNLESS OTHERWISE SPECIFIED: 0 PLC ± 1 PLC ± 2 PLC ± 3 PLC ± 4 PLC ± ANGLES ±		DWG: R. KNEPPER 22-Oct-13 CHK: G. BAILEY 22-Oct-13 APVD: M. CLIFFORD 22-Oct-13 NAME: Ocean Side Feed Applicator SIZE: A1 CAGE CODE: 00779 DRAWING NO: 2266126 SCALE: 1:2 SHEET: 1 of 4 REV: E	
MATERIAL: -		FINISH: -		WEIGHT: -	

LOC	DIST	REV	DATE	BY	APPV
A	66				
REVISIONS			DESCRIPTION	DATE	BY
			SEE SHEET 1		

FEED TYPE MECHANICAL

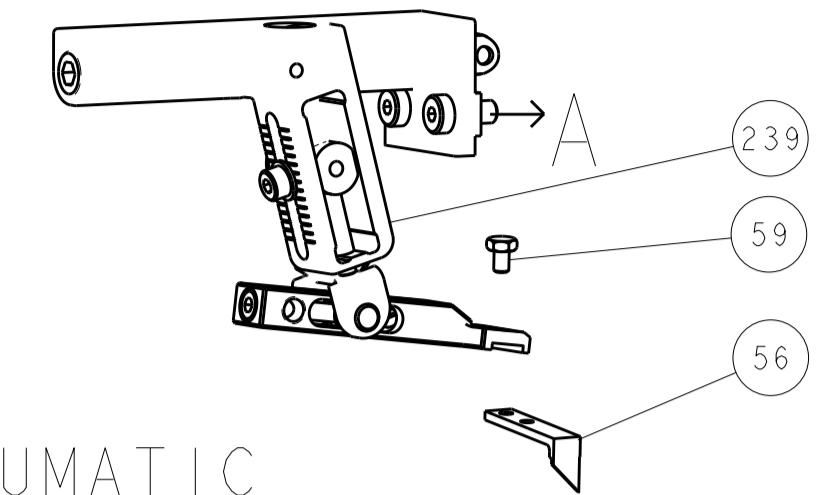

PNEUMATIC

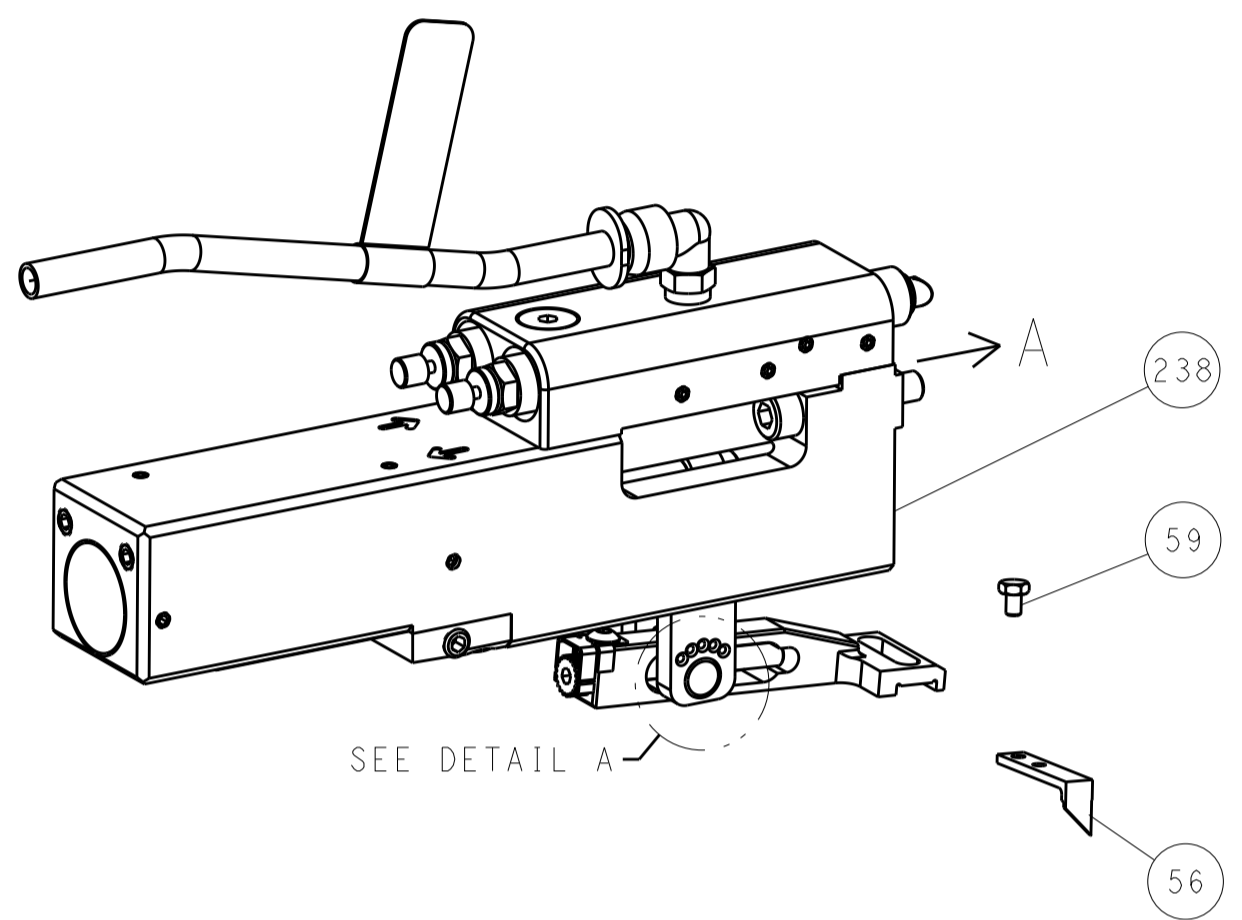

FEED SPRING SETTING POSITION (SHOWN FROM REAR SIDE)



DETAIL A

CAM POSITIONS

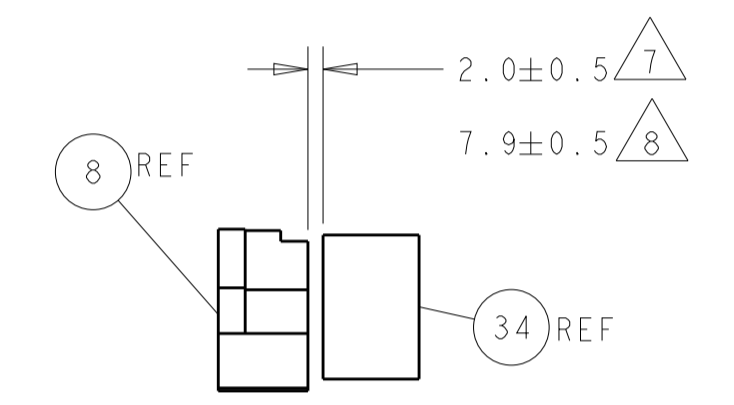
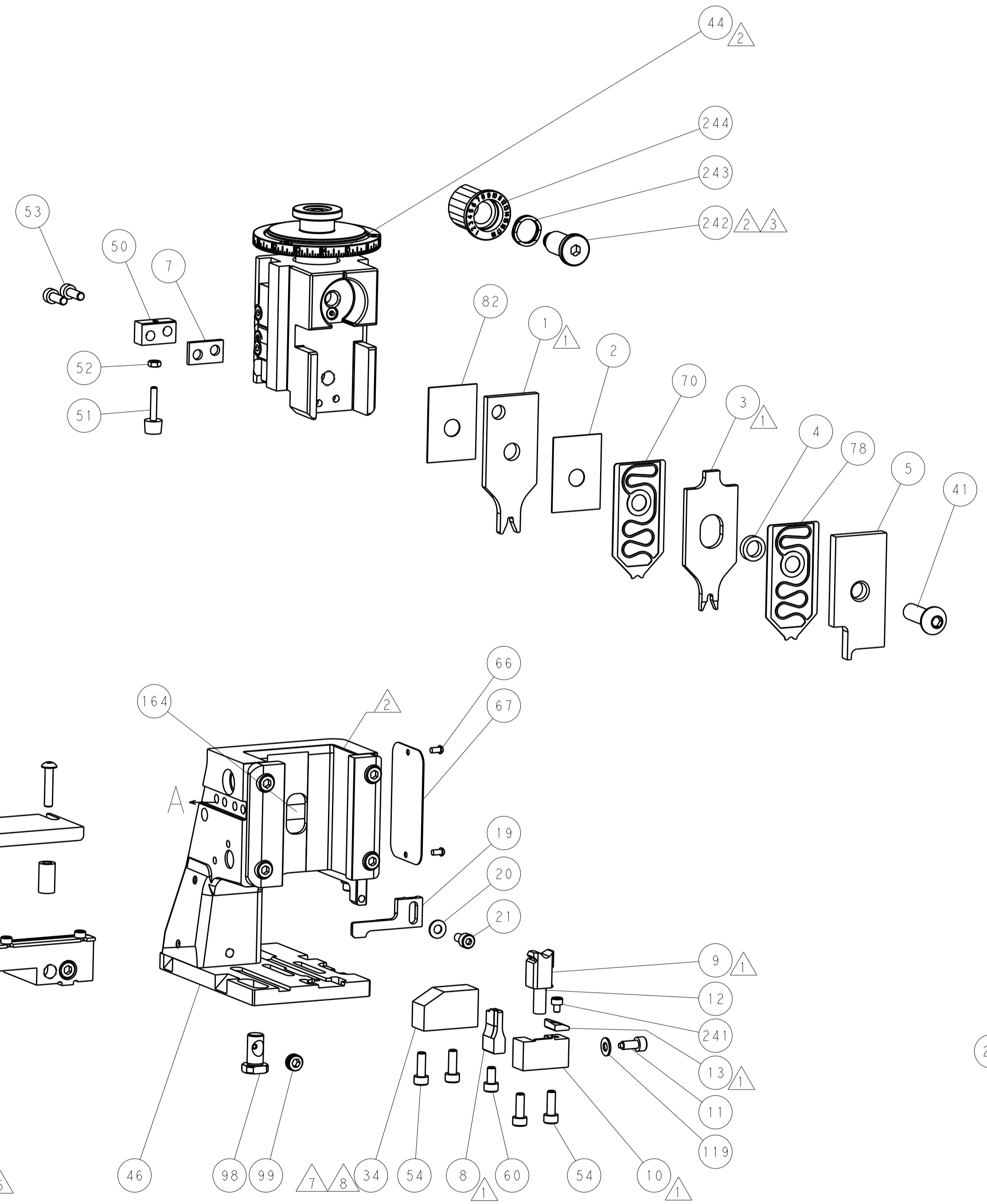

TERMINAL SUPPORT LOCATION

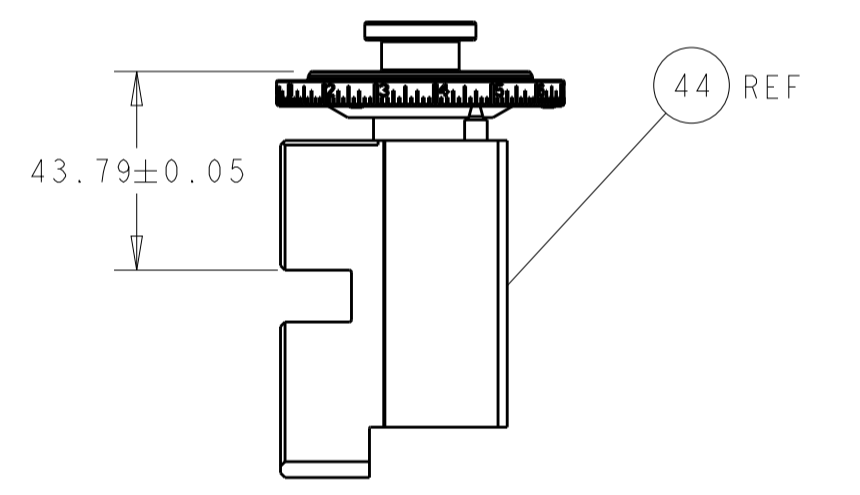

RAM SET-UP

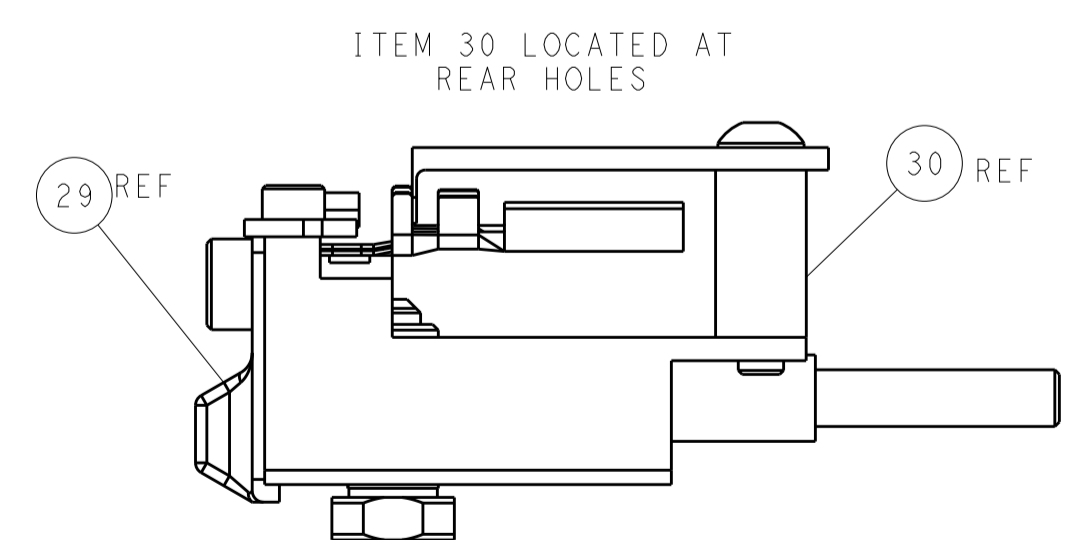

FEED TRACK POSITION GUIDE BY INSULATION BARREL

ATLANTIC VERSION
 Shown on sheets 1 of 4 & 2 of 4
 (Pacific version shown on sheets 3 of 4 & 4 of 4)

DIMENSIONS:		TOLERANCES UNLESS OTHERWISE SPECIFIED:		DWN R. KNEPPER 22-Oct-13		TE Connectivity	
mm	0 PLC ±	1 PLC ±	2 PLC ±	3 PLC ±	4 PLC ±	5 PLC ±	Harrisburg, PA 17105-3608
ANGLES	FINISH	MATERIAL		CHK G. BAILEY 22-Oct-13		NAME	
				M. CLIFFORD 22-Oct-13		Ocean Side Feed Applicator	
MATERIAL		FINISH		APVD		SIZE	
				CAGE CODE		DRAWING NO	
				A11 00779		C=2266126	
				WEIGHT		RESTRICTED TO	
				Customer Accessible Production Drawing		SCALE 1:2 SHEET 2 OF 4 REV E	

PART NUMBER	REVISION	DESCRIPTION	FEED TYPE
2-2266126-1	D	FINE CRIMP HEIGHT ADJUST	MECHANICAL
2-2266126-2	E	FINE CRIMP HEIGHT ADJUST	PNEUMATIC
7-2266126-7	B	CRIMP TOOLING KIT	-
7-2266126-8	B	APPLICATOR CONVERSION KIT	-

PACIFIC VERSION TERMINATOR
INTERFACE ADAPTER



APPLICATOR DATA		
CRIMP	SIZE	TYPE
WIRE	2.97 mm [.117]	F
INSUL	2.90 mm [.114]	O

APPLICATOR INSTRUCTIONS
408-35042

APPLICATOR CONVERSION KITS	
PART NUMBER	INSULATION DIAMETER RANGE
7-2266124-8	Ø3.83-4.47mm [.151-.176]
7-2266125-8	Ø3.27-3.81mm [.129-.150]
7-2266126-8	Ø2.87-3.25mm [.113-.128]

TERMINAL DATA: DEUTSCH TERMINAL DEUTSCH CRIMP SPECIFICATION			
TERMINAL NAME: STAMPED CONTACT PIN SIZE 12			
WIRE STRIP LENGTH	INSULATION DIAMETER RANGE	TE TERMINAL	DEUTSCH TERMINAL
5.71-6.99 mm [.225-.275 IN]	Ø2.87-3.43 mm [.113-.135 IN]	1572028-2	1060-12-0144
TERMINAL APPLICATION SPECIFICATION	114-151002	1572028-1	1060-12-0166

TERMINALS APPLIED

TE TERMINAL	DEUTSCH TERMINAL	TE TERMINAL	DEUTSCH TERMINAL
1572028-2	1060-12-0144	1572028-1	1060-12-0166

TERMINAL DATA: DEUTSCH TERMINAL DEUTSCH CRIMP SPECIFICATION			
TERMINAL NAME: STAMPED CONTACT SOCKET SIZE 12			
WIRE STRIP LENGTH	INSULATION DIAMETER RANGE	TE TERMINAL	DEUTSCH TERMINAL
5.71-6.99 mm [.225-.275 IN]	Ø2.87-3.43 mm [.113-.135 IN]	286955-2	1062-12-0144
TERMINAL APPLICATION SPECIFICATION	114-151002	286955-1	1062-12-0166

TERMINALS APPLIED

TE TERMINAL	DEUTSCH TERMINAL	TE TERMINAL	DEUTSCH TERMINAL
286955-2	1062-12-0144	286955-1	1062-12-0166

WIRE SIZE	CRIMP HEIGHT mm [INCH]	CRIMP HEIGHT REFERENCE SETTING
4.00mm2	2.24+0.03/-0.05 [.088+.001/-.002]	4.9
12 AWG	2.03+0.03/-0.05 [.080+.001/-.002]	7.2
3.00mm2	2.03+0.03/-0.05 [.080+.001/-.002]	7.4
2.50mm2	1.88+0.03/-0.05 [.074+.001/-.002]	8.3
14 AWG	1.78+0.03/-0.05 [.070+.001/-.002]	9.7
2.00mm2	1.78+0.03/-0.05 [.070+.001/-.002]	9.7

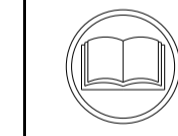

- 1 RECOMMENDED SPARE PARTS
- 2 REFER TO SUPPLIED INSTRUCTION SHEET FOR CLEANING, LUBRICATION AND STORAGE OF APPLICATOR.
- 3 APPLY PART NUMBER 2-23419-6 LOCTITE TO THREADS OF ITEM 242.
- 4 CRIMP HEIGHT REFERENCE SETTING WAS THE SETTING USED WHEN THE APPLICATOR WAS QUALIFIED AT THE FACTORY. ADJUSTMENT MAY BE NECESSARY WHEN RUNNING APPLICATOR IN THE FIELD.
- 5 TERMINAL LUBRICANT IS RECOMMENDED.
- 6. UNLESS SPECIFIED OTHERWISE TORQUE VALUES SHALL BE USED PER DOCUMENT, 101-35000.
- 7 DIMENSION 2.0±0.50 APPLIES TO PIN TERMINALS 1060-12-01XX.
- 8 DIMENSION 7.92±0.50 APPLIES TO SOCKET TERMINALS 1062-12-01XX.
- 9 SEE APPROPRIATE APPLICATOR LOG SHEETS FOR APPLIED TERMINALS AND WIRE RANGE.

***WARNING**
ON INSTALLATION, SET WIRE DISC TO CRIMP HEIGHT REFERENCE SETTING FOR LARGEST WIRE SIZE. CRIMP HEIGHT REFERENCE SETTINGS GREATER THAN THE VALUE SHOWN MAY CAUSE DAMAGE TO THE CRIMP TOOLING. REFER TO THE INSTRUCTION SHEET FOR PROPER SETUP AND ADJUSTMENTS.

LOC	DIST	REV	DATE	BY	APPV
A	66	-	-	-	-

REV	DATE	BY	APPV	DESCRIPTION	ITEM NO	
-	-	1	1	2119082-9	CAM, SNAIL, INSULATION ADJUSTMENT	244
-	-	1	1	2079764-1	WASHER, WAVE SPRING, CREST-TO-CREST	243
-	-	1	1	2119083-1	RETAINER, INSULATION DIAL	242
-	-	1	1	7-18023-7	SCR, SKT HD CAP M3 X 4.0	241
-	-	-	1	2119580-1	MECHANICAL FEED ASSEMBLY	239
-	-	1	-	2844940-1	AIR FEED MODULE	238
-	-	REF	REF	994970-2	COUNTER, MAGNETIC	164
-	-	1	-	2119641-2	FEED CAM, AIR FEED	151
-	-	1	1	2168083-8	SCR, SKT HD CAP, RoHS, M4 X 16	144
-	-	4	4	2168083-9	SCR, SKT HD CAP, RoHS, M4 X 20	143
-	-	-	1	2119653-2	FEED CAM, POST FEED	142
-	-	1	1	1-1803583-0	APPLICATOR BASIC ASSEMBLY, SF	141
-	-	1	1	1803516-1	RAM ASSEMBLY, SF PACIFIC	140
-	-	1	1	1-18028-2	WASHER, FLAT, REG M4	119
-	-	1	1	2119955-1	ASSY, LUBRICATOR, SIDE FEED	113
-	-	1	1	2844908-1	SCREW, LOCKING	99
-	-	1	1	2844907-1	POST, LOCKING	98
-	-	1	1	455888-5	SPACER, CRIMPER	82
-	-	1	1	2119791-9	DEPRESSOR, WIRE	78
1	-	-	-	2266126	PRINT, APPLICATOR LOG SHEET	72
-	-	1	1	1803607-3	DOCUMENTATION PACKAGE	71
-	-	1	1	2119791-9	DEPRESSOR, WIRE	70
-	-	1	1	2119740-1	TAG, IDENTIFICATION	67
-	-	2	2	2168078-1	SCREW, DRIVE, RH, RoHS, 2 x .188	66
-	-	1	1	5-18022-5	SCR, HEX HD CAP, M4 X 6.0	59
-	-	1	1	1338685-1	PAWL, FEED	56
2	-	2	2	2168083-3	SCR, SKT HD CAP, RoHS, M4 X 12.0	53
-	-	1	1	5018030-1	NUT, HEX, REG, RoHS, M3	52
-	-	1	1	811242-5	BUMPER, HOLD DOWN	51
-	-	1	1	690753-2	SPACER, TONKER	50
-	-	1	2	18023-9	SCR, SKT HD CAP M4 X 6.0	49
-	-	-	1	2119652-1	FEED CAM, PRE FEED	48
-	-	1	1	1803602-1	SCR, BHSC, RoHS (M8 X 25)	41
-	-	1	1	1752356-6	SUPPORT, TERMINAL	34
-	-	2	2	2079383-5	SCR, BHSC, RoHS (M4 X 20)	33
-	-	2	2	2-2844962-8	SPACER, CYLINDRICAL, STRIP GUIDE	30
-	-	1	1	2844992-1	ASSEMBLY, STRIP GUIDE	29
-	-	1	1	1320928-6	STRIP GUIDE	24
-	-	1	1	2168083-2	SCR, SKT HD CAP, RoHS, M4 X 8.0	21
-	-	1	1	1-18028-2	WASHER, FLAT, REG M4	20
-	-	1	1	2119533-1	STRIPPER, SIDE FEED	19
-	-	1	1	2119806-1	INSERT, SHEAR	13
-	-	1	1	3-22280-3	SPRING, COMPRESSION	12
-	-	1	1	1-356885-4	STOP, SHEAR	11
-	-	1	1	2119805-1	SHEAR HOLDER, FRONT	10
-	-	1	1	1803095-1	FLOATING SHEAR, FRONT	9
1	1	1	1	2-1803293-2	ANVIL, COMBINATION DEUTSCH STYLE	8
-	-	1	1	3-240641-7	SPACER	7
-	-	-	-	-	-	6
1	-	1	1	2119757-8	DEPRESSOR, SHEAR	5
-	-	1	1	238011-2	BLOCK, CRIMPER SPACER	4
1	1	1	1	2-1803019-8	CRIMPER, INSULATION O	3
-	-	1	1	455888-4	SPACER, CRIMPER	2
1	-	1	1	4-1633713-6	CRIMPER, WIRE PREMIUM	1

PACIFIC VERSION
Shown on sheets 3 of 4 & 4 of 4
(Atlantic version shown on sheets 1 of 4 & 2 of 4)

DIMENSIONS:		TOLERANCES UNLESS OTHERWISE SPECIFIED:		MATERIAL:		FINISH:	
mm	0 PLC ±	1 PLC ±	2 PLC ±	3 PLC ±	4 PLC ±	ANGLES ±	FINISH ±

DRN	R. KNEPPER	22-Oct-13
CHK	G. BAILEY	22-Oct-13
APPV	M. CLIFFORD	22-Oct-13

NAME	Ocean Side Feed Applicator		
SIZE	CAGE CODE	DRAWING NO	RESTRICTED TO
A1	00779	2266126	-

Customer Accessible Production Drawing SCALE 1:2 SHEET 3 OF 4 REV E

LOC		DIST		REVISIONS			
A	66	P	LTM	DESCRIPTION	DATE	OWN	APVD
		-		SEE SHEET 1			

FEED TYPE MECHANICAL

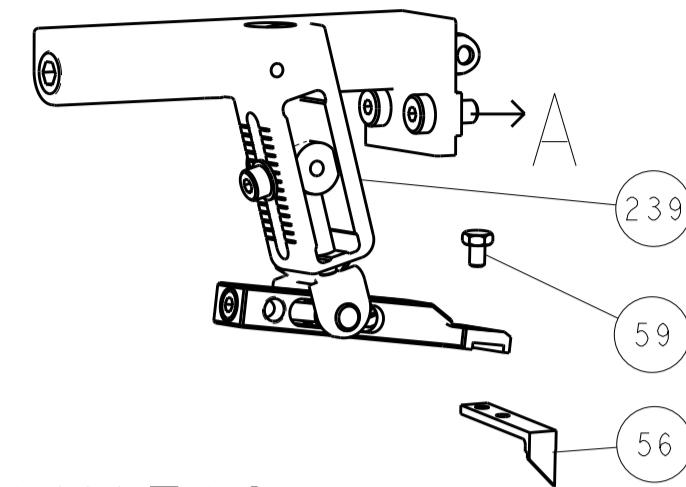

PNEUMATIC

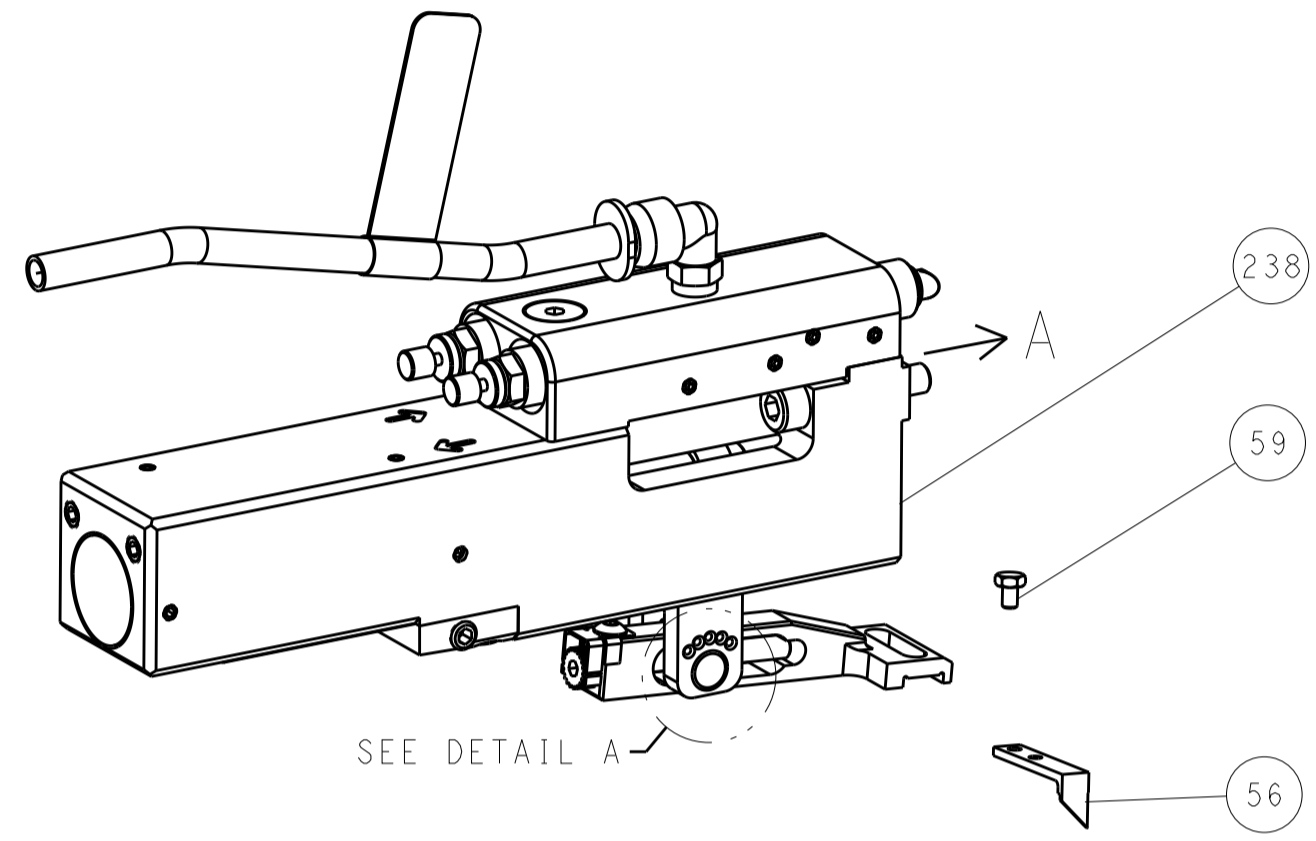

FEED SPRING SETTING POSITION (SHOWN FROM REAR SIDE)



DETAIL A

CAM POSITIONS

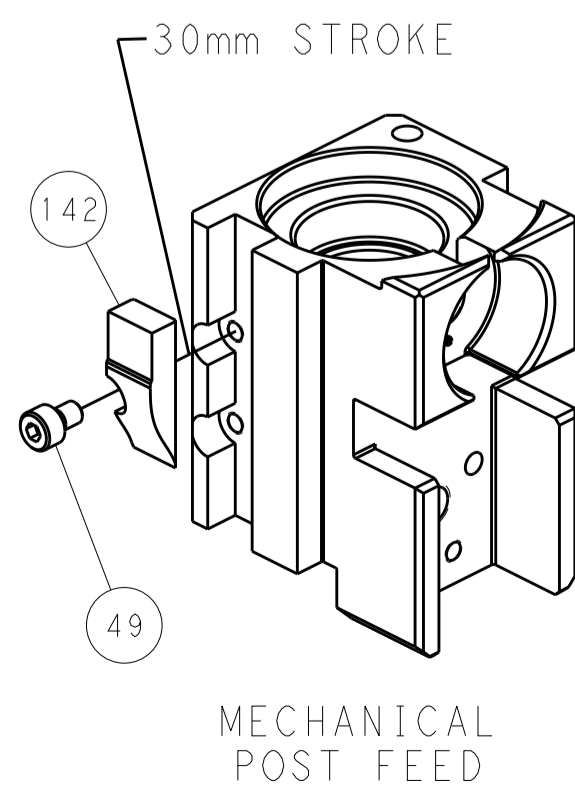

MECHANICAL POST FEED

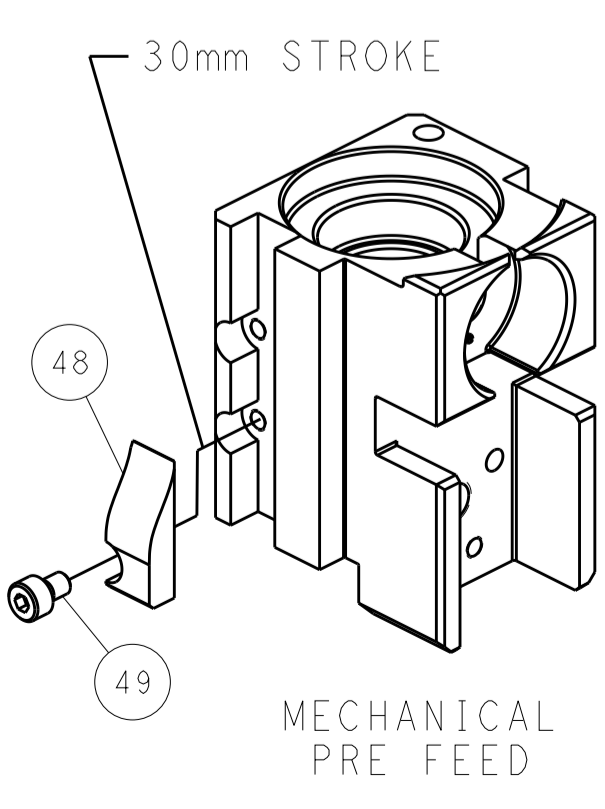

MECHANICAL PRE FEED

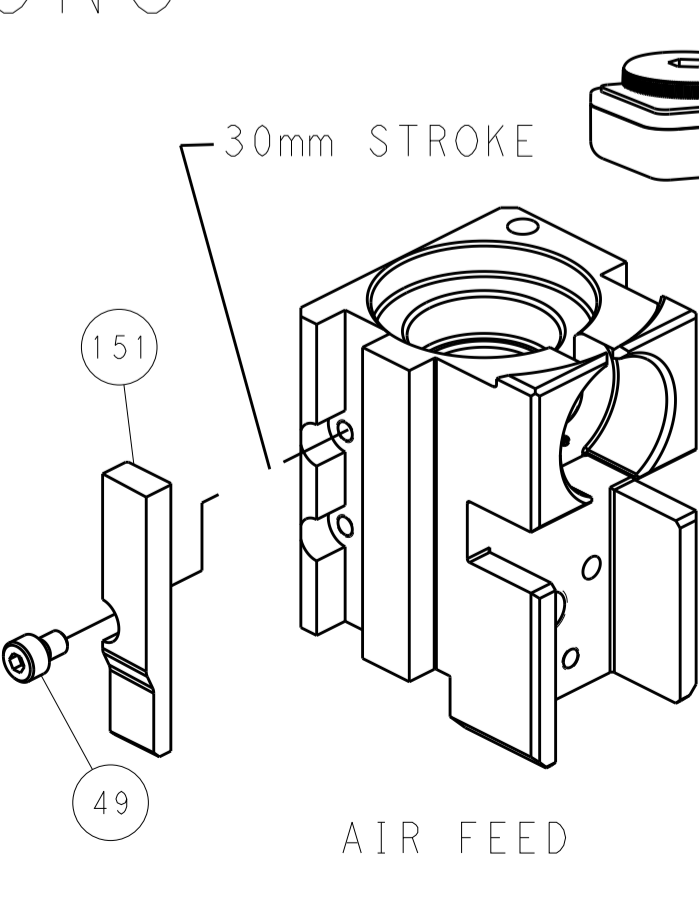

AIR FEED

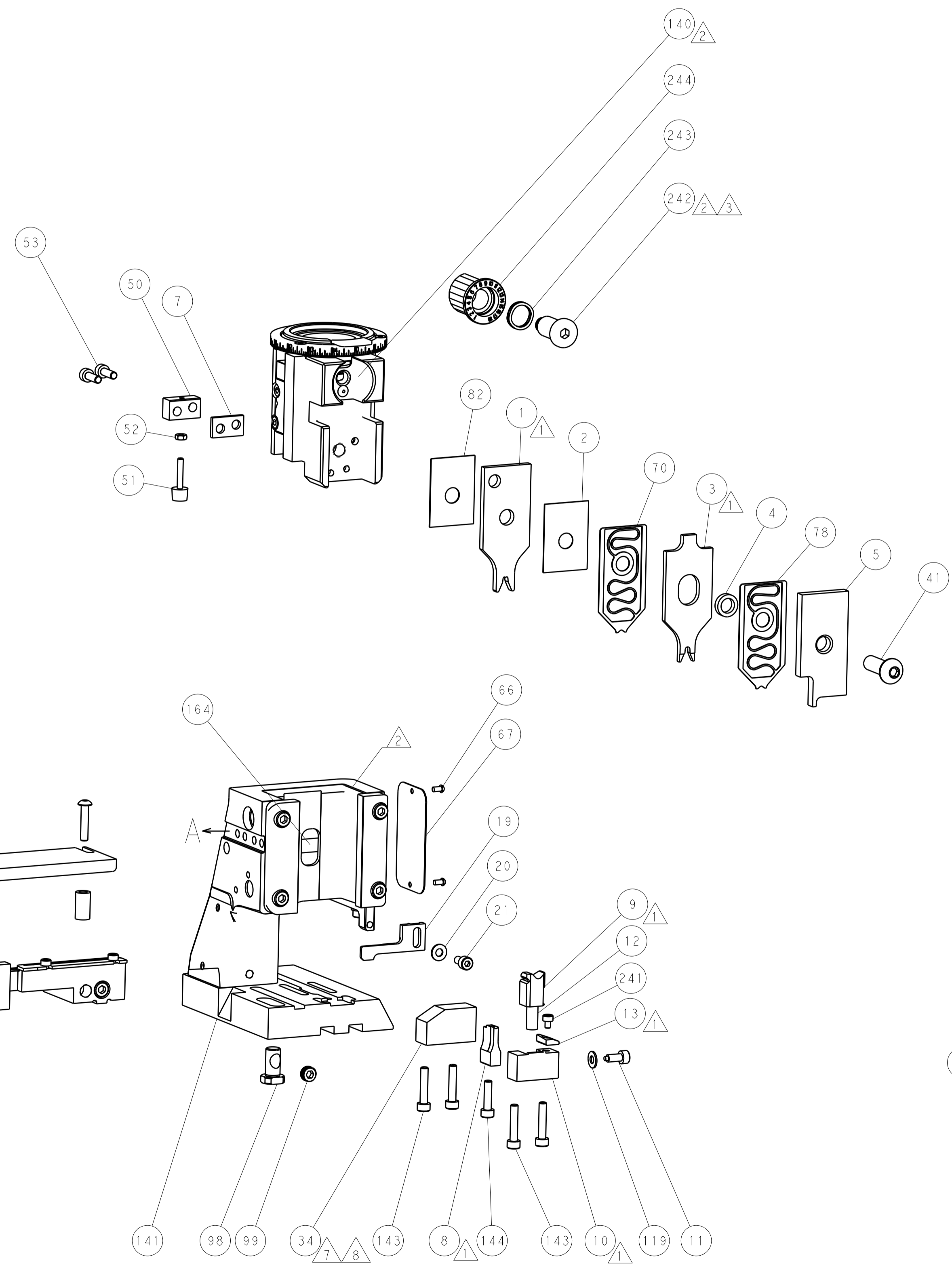

PACIFIC VERSION
 Shown on sheets 3 of 4 & 4 of 4
 (Atlantic version shown on sheets 1 of 4 & 2 of 4)

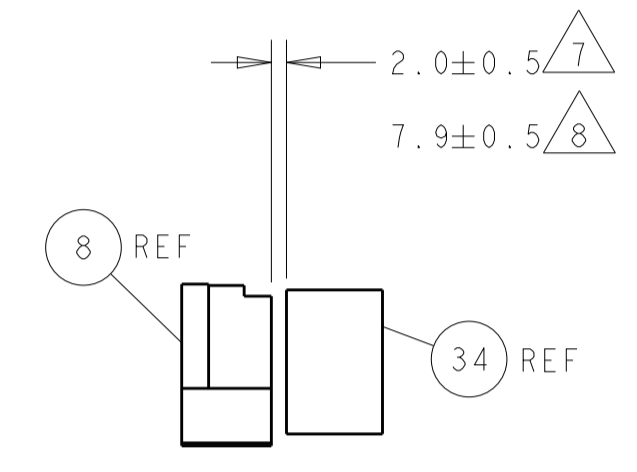

TERMINAL SUPPORT LOCATION

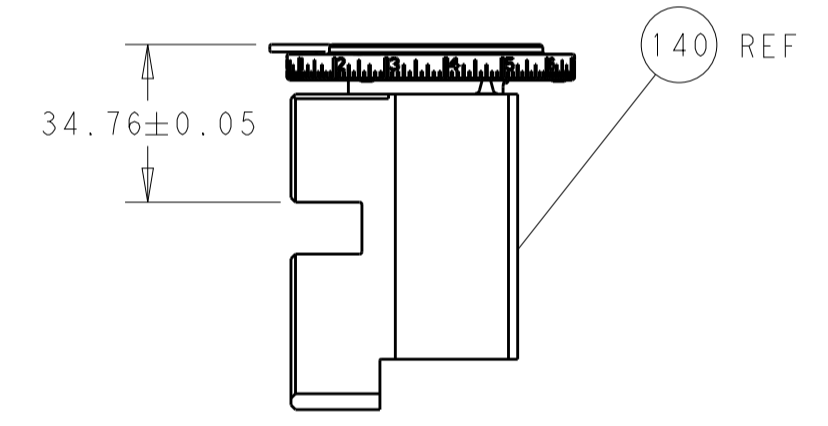

RAM SET-UP

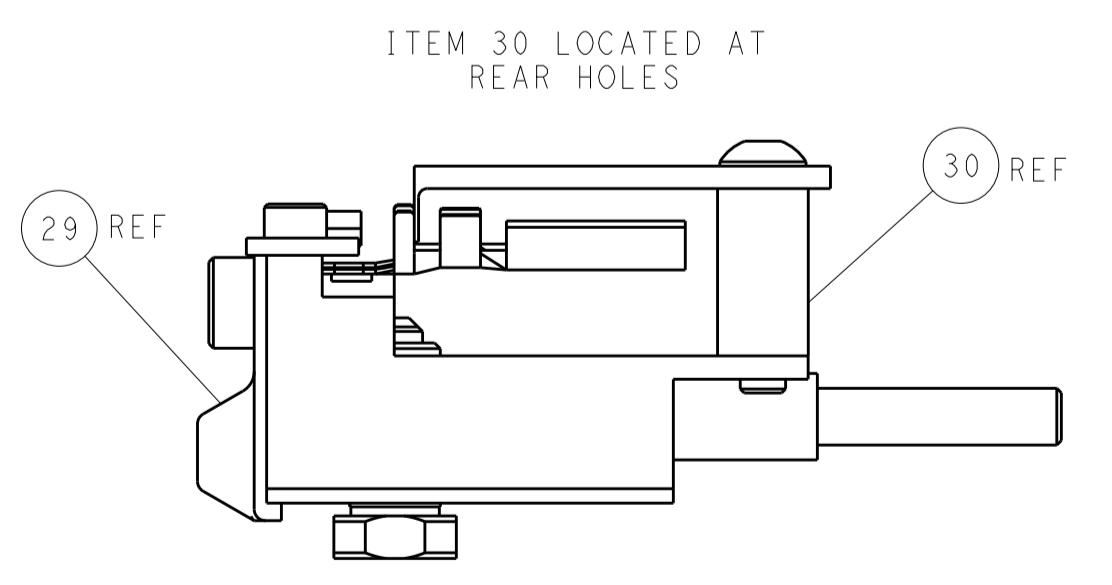

FEED TRACK POSITION GUIDE BY INSULATION BARREL

DIMENSIONS: mm 		TOLERANCES UNLESS OTHERWISE SPECIFIED: 0 PLC ± 1 PLC ± 2 PLC ± 3 PLC ± 4 PLC ± ANGLES ±		DWN R. KNEPPER 22-Oct-13 CHK G. BAILEY 22-Oct-13 APVD M. CLIFFORD 22-Oct-13 PRODUCT SPEC APPLICATION SPEC WEIGHT SCALE 1:2		NAME Ocean Side Feed Applicator SIZE CAGE CODE DRAWING NO A1 00779 C=2266126 RESTRICTED TO REV E	
MATERIAL: FINISH:				Customer Accessible Production Drawing			