

PART NUMBER	REVISION	DESCRIPTION	FEED TYPE
2266739-2	E	FINE CRIMP HEIGHT ADJUST	PNEUMATIC
7-2266739-7	C	CRIMP TOOLING KIT	-

ATLANTIC VERSION TERMINATOR
 INTERFACE ADAPTER

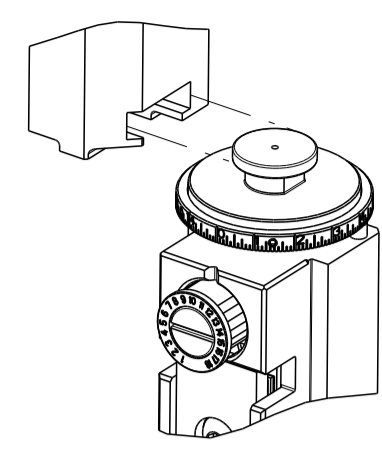

APPLICATOR DATA

CRIMP	SIZE	TYPE
WIRE	5.33 mm [.210]	F
INSUL	11.18 mm [.440]	O

APPLICATOR INSTRUCTIONS
 408-35042

TERMINAL DATA: TE TERMINAL TE CRIMP SPECIFICATION

TERMINAL NAME: TAB 9.5mm X 1.2mm

WIRE STRIP LENGTH	INSULATION DIAMETER RANGE
9.10-9.70 mm [.358-.382 IN]	Ø

TERMINAL APPLICATION SPECIFICATION 114-94407

TERMINALS APPLIED

TE TERMINAL	TE TERMINAL	TE SEAL	TE SEAL	SEAL INSULATION DIAMETER RANGE
2-2287018-1			2287390-5	4.6-6.0
2-2287018-3				

WIRE SIZE	CRIMP HEIGHT mm [INCH]	CRIMP HEIGHT REFERENCE SETTING
10.00mm2	3.35 +/- 0.10 [.132 +/- .004]	2.6
8.00mm2	3.05 +/- 0.10 [.120 +/- .004]	5.8

- RECOMMENDED SPARE PARTS
- REFER TO SUPPLIED INSTRUCTION SHEET FOR CLEANING, LUBRICATION AND STORAGE OF APPLICATOR.
- APPLY PART NUMBER 2-23419-6 LOCTITE TO THREADS OF ITEM 242.
- CRIMP HEIGHT REFERENCE SETTING WAS THE SETTING USED WHEN THE APPLICATOR WAS QUALIFIED AT THE FACTORY. ADJUSTMENT MAY BE NECESSARY WHEN RUNNING APPLICATOR IN THE FIELD.
- TERMINAL LUBRICANT IS RECOMMENDED.
- UNLESS SPECIFIED OTHERWISE TORQUE VALUES SHALL BE USED PER DOCUMENT, 101-35000.
- TERMINAL PITCH NOT COMPATIBLE WITH MECHANICAL FEED.
- APPLY TORO-SEAL IN ALLEN SOCKET TO FILL HOLE AFTER SOCKET HD HAS BEEN ADJUSTED TO CORRECT HEIGHT AT QUALIFICATION.
- CUT TO LENGTH AT ASSEMBLY.

***WARNING**
 ON INSTALLATION, SET WIRE DISC TO CRIMP HEIGHT REFERENCE SETTING FOR LARGEST WIRE SIZE. CRIMP HEIGHT REFERENCE SETTINGS GREATER THAN THE VALUE SHOWN MAY CAUSE DAMAGE TO THE CRIMP TOOLING. REFER TO THE INSTRUCTION SHEET FOR PROPER SETUP AND ADJUSTMENTS.

LOC	DIST	REVISIONS					
A	66	P	LTN	DESCRIPTION	DATE	OWN	APVD
		C		ECR-17-009111	22JUN2017	TB	GB
		D		ECR-17-013780	18SEP2017	TB	GB
		E		ECR-19-011304	18JUL2019	TB	TE
		E1		ECR-24-213910	05JUL2024	ZZ	GB

-	2	2168083-1	SCR, SKT HD CAP, RoHS, M3 X 8.0	269	
-	1	1633782-7	FENCE	267	
-	1	2119641-1	FEED CAM, AIR FEED	248	
-	1	2119082-6	CAM, SNAIL, INSULATION ADJUSTMENT	244	
-	1	2079764-1	WASHER, WAVE SPRING, CREST-TO-CREST	243	
3	-	1	2119083-1	RETAINER, INSULATION DIAL	242
-	1	2844940-2	AIR FEED MODULE	238	
-	REF	994970-2	COUNTER, MAGNETIC	164	
5	-	1	2119955-1	ASSY, LUBRICATOR, SIDE FEED	113
-	1	2844908-1	SCREW, LOCKING	99	
-	1	2844907-1	POST, LOCKING	98	
-	1	455888-7	SPACER, CRIMPER -	82	
-	1	2-240641-4	SPACER	81	
9	-	2	2079383-4	SCR, BHSC, RoHS (M4 X 8)	79
-	1	1803096-1	EXTENSION PLATE	78	
-	1	1803607-3	DOCUMENTATION PACKAGE	71	
-	1	1-2119791-1	DEPRESSOR, WIRE	70	
-	1	2119943-1	WASHER, SPACER	69	
-	1	2119740-1	TAG, IDENTIFICATION	67	
-	2	2168078-1	SCREW, DRIVE, RH, RoHS, 2 x .188	66	
-	1	2168083-2	SCR, SKT HD CAP, RoHS, M4 X 8.0	60	
-	1	5-18022-5	SCR, HEX HD CAP, M4 X 6.0	59	
8	-	1	1-2168083-3	SCR, SKT HD CAP, RoHS, M3 X 16	57
-	1	1-1338683-1	FEED PAWL	56	
-	4	2168083-3	SCR, SKT HD CAP, RoHS, M4 X 12.0	54	
-	2	2168083-9	SCR, SKT HD CAP, RoHS, M4 X 20	53	
-	1	1803382-4	HOLD DOWN, SPRING LOADED	50	
-	1	18023-9	SCR, SKT HD CAP M4 X 6.0	49	
-	1	2-1803583-6	APPLICATOR BASIC ASSEMBLY, SF	46	
-	1	1803515-2	RAM ASSEMBLY, SF ATLANTIC	44	
-	1	1803602-2	SCR, BHSC, RoHS (M8 X 40)	41	
-	1	1752356-8	SUPPORT, TERMINAL	34	
-	2	2079383-5	SCR, BHSC, RoHS (M4 X 20)	33	
-	2	3-2844962-2	SPACER, CYLINDRICAL, STRIP GUIDE	30	
-	1	2844992-5	ASSEMBLY, STRIP GUIDE -	29	
-	1	3-455888-7	SPACER, CRIMPER -	28	
-	2	1-22284-0	SPRING, COMPRESSION	27	
-	1	240792-1	DRAG, TERMINAL	25	
-	1	1320928-2	STRIP GUIDE -	24	
-	1	1-690438-0	FRONT STRIP GUIDE	23	
-	1	2168083-2	SCR, SKT HD CAP, RoHS, M4 X 8.0	21	
-	2	1-18028-2	WASHER, FLAT, REG M4	20	
-	1	1803013-1	STRIPPER, SIDE FEED	19	
-	1	5018030-1	NUT, HEX, REG, RoHS, M3	16	
-	1	1-455888-0	SPACER, CRIMPER -	15	
-	1	3-22280-3	SPRING, COMPRESSION	12	
-	1	1-356885-3	STOP, SHEAR	11	
1	-	1	2-2119805-0	SHEAR HOLDER, FRONT -	10
1	-	1	1-318059-2	FLOATING SHEAR, FRONT	9
1	1	1-1803383-7	ANVIL, COMBINATION	8	
-	1	2-240641-5	SPACER	7	
-	-	-	-	6	
-	1	1-1803080-2	DEPRESSOR, SHEAR	5	
-	1	4-238011-4	BLOCK, CRIMPER SPACER	4	
1	1	5-1633966-7	CRIMPER, INSULATION O	3	
-	1	455888-6	SPACER, CRIMPER -	2	
1	1	1-1633773-3	CRIMPER, WIRE, STEP	1	

DIMENSIONS: mm 		TOLERANCES UNLESS OTHERWISE SPECIFIED: 0 PLC ± 1 PLC ± 2 PLC ± 3 PLC ± 4 PLC ± ANGLES ± FINISH		DWG: BOB HIGMAN 29APR2015 CHK: T. ELBIN 29APR2015 APVD: T. ELBIN 29APR2015 PRODUCT SPEC APPLICATION SPEC WEIGHT: - SCALE: A 00779 C=2266739		NAME: Ocean Side Feed Applicator SIZE: - CAGE CODE: - DRAWING NO: - RESTRICTED TO: - Customer Accessible Production Drawing SCALE: 1:2 SHEET: 1 OF 4 REV: E1	
-----------------------	--	---	--	---	--	--	--

