

4

3

2

1

THIS DRAWING IS UNPUBLISHED.

RELEASED FOR PUBLICATION

© COPYRIGHT

ALL RIGHTS RESERVED.

LOC DIST

REVISIONS

P	LTR	DESCRIPTION	DATE	DWN	APVD

REPLACED BY OCEAN STYLE APPLICATOR PART NUMBER

FOR REPLACEMENT PARTS FOR APPLICATOR REFER TO ADDITIONAL PAGE(S). SPARE PARTS KIT (IF LISTED) WILL REMAIN AVAILABLE.

THE REPLACEMENT OCEAN STYLE APPLICATOR HAS THE SAME TERMINATOR/PRESS INTERFACE AS APPLICATOR

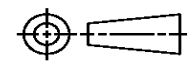
THIS DRAWING IS A CONTROLLED DOCUMENT.		DWN	 TE Connectivity		
DIMENSIONS:		CHK			
TOLERANCES UNLESS OTHERWISE SPECIFIED:		APVD	NAME		
		PRODUCT SPEC	RESTRICTED TO		
		APPLICATION SPEC	SIZE	CAGE CODE	DRAWING NO
MATERIAL	FINISH	WEIGHT	A3	C-	
		SCALE	SHEET	OF	REV

PART NUMBER	REV	FIRST USED	POWER UNIT	FEED TYPE	DESCRIPTION
680210-1	G	122500-1	LEADMAKER	POST FEED	CUTS CARRIER
680210-2	H	565435-5	BENCH MODEL K	PRE FEED	CUTS CARRIER
680210-3	G	354500-1	BENCH MODEL G	PRE FEED	CUTS CARRIER
680210-6	G	122500-1	LEADMAKER	POST FEED	CONTINUOUS CARRIER
7-680210-7	G	-	-	-	SPARE PARTS

- △ RECOMMENDED SPARE PARTS
- △ GREASE LIGHTLY
- △ GUARD MUST BE IN PLACE WHEN OPERATING APPLICATOR IN A BENCH MACHINE
- △ APPLY TORO-SEAL IN ALLEN SOCKET TO FILL HOLE AFTER FLAT HD HAS BEEN ADJUSTED TO CORRECT HEIGHT AT QUALIFICATION. APPLY PN 1-23419-5 LOC-TITE TO THREADS.
- △ GUIDE OFF INSULATION BARREL.

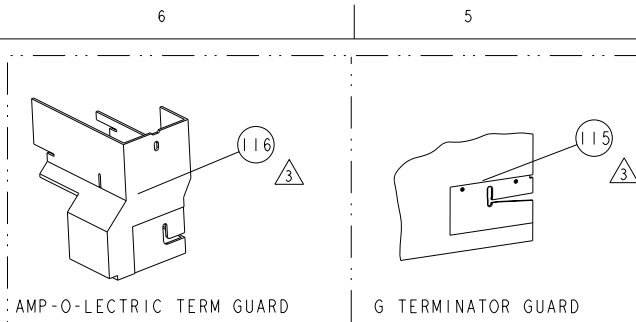

TERMINAL NAME: TAB 2.80x0.8 ASSEMBLY					
TEC PN		TEC TERMINAL - TEC CRIMP SPECS			
962915	-				
		PAD LTR	CRIMP HEIGHT	WIRE SIZE	
		A	1.36mm±.05/-.05 [.054±.002/- .002]	1mm2	
		B	1.27mm±.05/-.05 [.050±.002/- .002]	0.75mm2	
		C	1.18mm±.05/-.05 [.046±.002/- .002]	0.5mm2	
		D	-	-	
		CRIMP	SIZE	TYPE	RANGE
SEAL PN.	828904	WIRE	2.03mm [.080]	F	0.50-1.00
		INSUL	4.06mm [.160]	O	Ø2.100 MAX
WIRE STRIP LENGTH	4.200-4.950	TERM APPL SPEC	114-18081	FEED	14.500
		APPLICATOR INSTRUCTIONS 408-8040			SET UP GAGE 458637-1

LOC		DIST		REVISIONS				
A	66	#	DATE	DESCRIPTION	BY	CHKD	APPD	
		G	28MAY2008	ECR-08-013587	BH			BH
		H	31MAY2012	ECR-12-009832	MY			GB

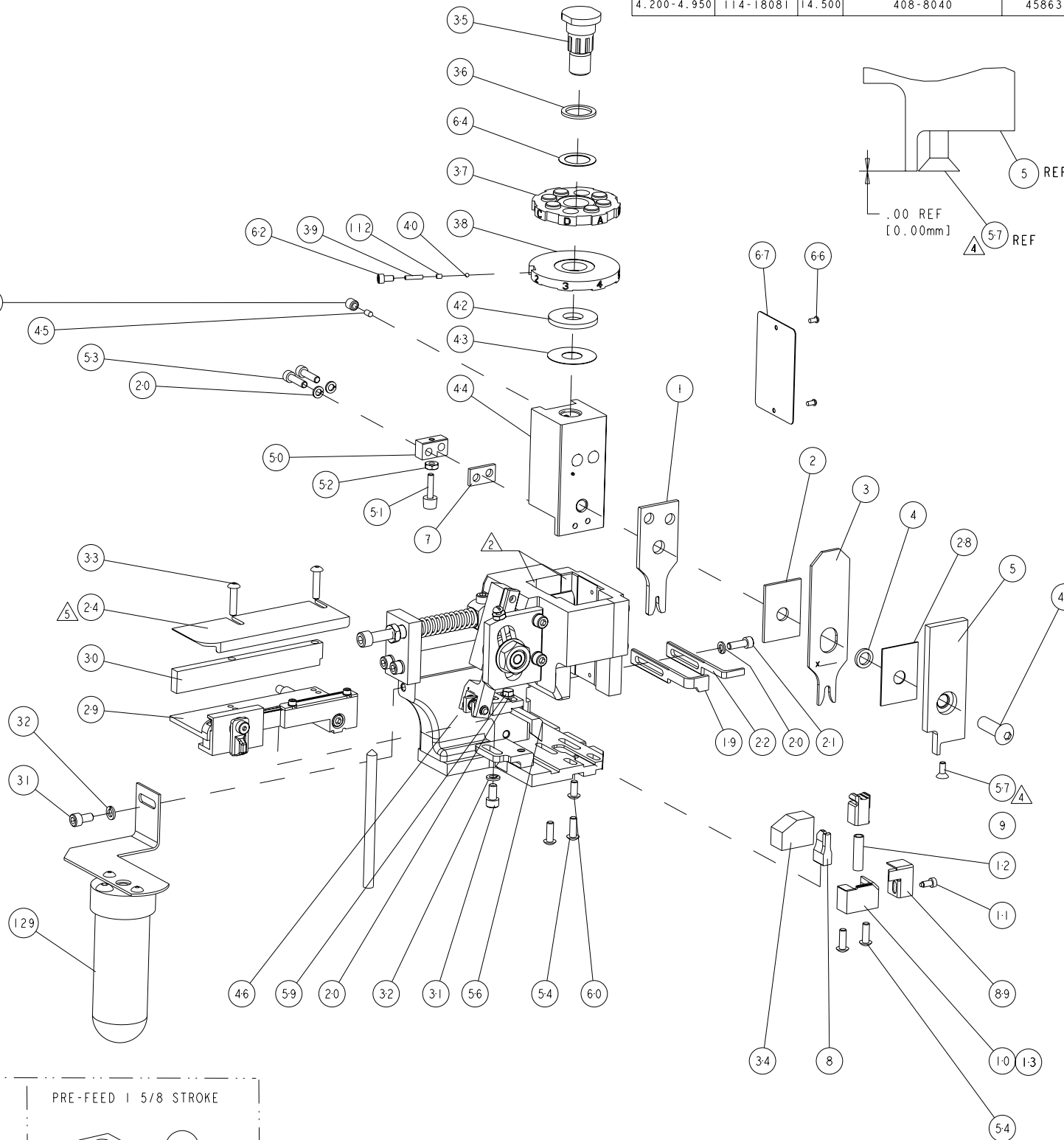
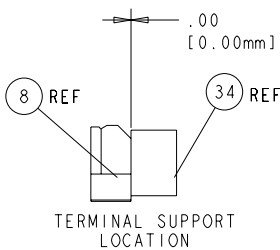
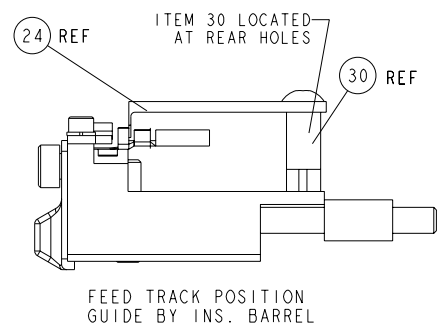
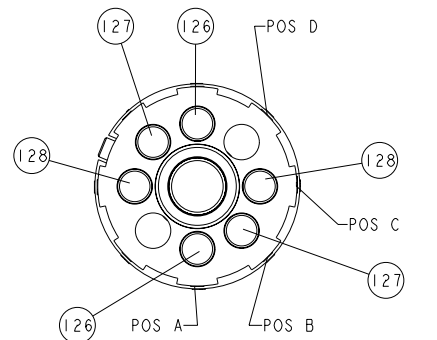

-	-	1	-	1-455184-0	LUBRICATOR ASSY	129
-	2	2	2	3-354779-0	PIN, WIRE DISC, .3140	128
-	2	2	2	2-354779-2	PIN, WIRE DISC, .3100	127
-	2	2	2	1-354779-4	PIN, WIRE DISC, .3060	126
△	-	-	REF	455749-1	GUARD WINDOW	116
△	-	REF	-	679532-1	INSERT, GUARD	115
-	1	1	1	690603-1	SPRING ASSIST AMP-O-MATOR APPLICATOR	112
-	1	1	1	1-21002-7	SCR, BTN SKT HD CAP 6-32 X .375	91
-	1	1	1	318563-1	GUARD, FRONT CHIP	89
-	1	1	1	4088040	SF APPL INST 408-8040	72
-	1	1	1	217238-1	GENERAL INSTRUCTION PKG	71
-	1	1	1	461264-1	PLATE, IDENTIFICATION	67
-	2	2	2	21017-2	SCREW, DRIVE	66
-	1	1	1	986950-1	WASHER, FLAT PRECISION	64
-	1	1	1	21009-2	SCR, SET, SELF LOCKING 1/4-20 X .250	63
-	1	1	1	23030-1	SCR, SKT HD CAP 6-32 X .25	62
-	1	1	1	22733-8	SCR, BHSC, SELF-LOCKING, 8-32 X .375	60
-	1	1	1	2-22603-0	SCR, HEX HD CAP 8-32 X .312	59
-	1	1	1	1-21003-9	SCR, FLT SKT HD CAP 6-32 X .375	57
△	-	1	1	1-694433-6	FEED PAWL	56
-	4	4	4	2-21002-2	SCR, BTN SKT HD CAP 8-32 X .500	54
-	2	2	2	2-21000-8	SCR, SKT HD CAP 8-32 X .625	53
-	1	1	1	21018-5	NUT, HEX, REG 6-32	52
-	1	1	1	811242-2	BUMPER, HOLD DOWN	51
-	1	1	1	690753-1	SPACER, TONKER	50
-	-	1	-	690602-6	CAM, PRE FEED, 1 5/8	49
-	-	1	-	690602-5	CAM, PRE FEED, 1 1/8	48
-	1	-	-	690501-4	CAM, POST-FEED 1 5/8	47
-	1	1	1	459456-1	APPL. BASIC SUB ASSY (SIDE WISE MQCA)	46
-	1	1	1	690191-1	PLUG, NYLON	45
-	1	1	1	455673-1	RAM, SIDE FEED	44
-	1	1	1	690125-1	SHIM SUB-ASSY	43
-	1	1	1	690124-1	WASHER, RAM (.115)	42
-	1	1	1	7-21002-9	SCR, BTN SKT HD CAP 5/16-24 X 1.00	41
-	1	1	1	23241-6	BALL, STEEL	40
-	1	1	1	690170-1	SPRING, COMPRESSION	39
-	1	1	1	690142-1	DISC, INSULATION	38
-	1	1	1	354777-1	WIRE DISC, ASSEMBLY	37
-	1	1	1	22480-5	SPRING, COMPRESSION	36
-	1	1	1	690212-1	POST, RAM	35
-	1	1	1	690786-4	TERMINAL SUPPORT	34
-	2	2	2	2-21002-4	SCR, BTN SKT HD CAP 8-32 X .750	33
-	1	1	2	21024-5	WASHER, SPRG LOCK, REG NO 10	32
-	1	1	2	3-21000-4	SCR, SKT HD CAP 10-32 X .375	31
-	1	1	1	1-1320908-0	SPACER, STRIP GUIDE	30
-	1	1	1	1633091-3	ASSEMBLY, STRIP GUIDE	29
-	1	1	1	455888-7	SPACER, CRIMPER	28
-	1	1	1	1320928-6	STRIP GUIDE	24
-	1	-	-	690472-2	STRIPPER	22
-	1	1	1	2-21000-7	SCR, SKT HD CAP 8-32 X .500	21
-	4	4	4	21024-4	WASHER, SPRG LOCK, REG NO 8	20
-	-	1	-	691353-1	STRIPPER	19
△	-	1	-	679625-2	SHEAR HOLDER, FRONT (NO CUT)	13
-	1	1	1	3-22280-3	SPRING, COMPRESSION	12
-	1	1	1	690461-2	STOP, SHEAR	11
△	-	1	-	1-690459-0	SHEAR HOLDER, FRONT	10
△	-	1	-	318707-2	FLOATING SHEAR, FRONT	9
△	1	1	1	5-854014-3	ANVIL, COMBINATION	8
-	1	1	1	240641-9	SPACER	7
-	-	-	-	-	-	6
-	1	1	1	318701-1	DEPRESSOR, SHEAR	5
-	1	1	1	238011-7	BLOCK, CRIMPER SPACER	4
△	1	1	1	8-683454-6	CRIMPER, INSULATION O	3
-	1	1	1	1-455888-7	SPACER, CRIMPER	2
△	1	1	1	1-456405-5	CRIMPER, WIRE PREMIUM	1

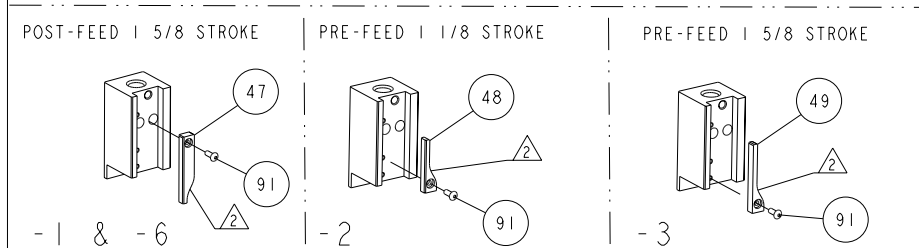

THIS DRAWING IS A CONTROLLED DOCUMENT. DIMENSIONING AND TOLERANCING PER ASME Y14.5M-2009.		DWG: B.HIGMAN 28MAY2008		REV: T.ELBIN 28MAY2008	
DIMENSIONS: INCHES		TOLERANCES UNLESS OTHERWISE SPECIFIED:		APPROVED: N. DEMING 28MAY2008	
0 PLC ±.01		1 PLC ±.01		NAME: SIDE FEED HDM APPLICATOR	
2 PLC ±.01		3 PLC ±.01		SIZE: A1	
4 PLC ±.0001		ANGLES ±.0001		CAGE CODE: 00779	
MATERIAL: -		FINISH: -		DRAWING NO: 680210	
CUSTOMER ACCESSIBLE PRODUCTION DRAWING		SCALE: 3:5		SHEET 1 OF 1	