



5.0 Power Key (PK) Connector SMT Product Specification

1. SCOPE

1.1. Content

This specification covers performance, tests and quality requirements for the TE Connectivity (TE) 5.0mm Power Key (PK) Connector SMT System. The 5.0 PK SMT product is a wire-to-board and mass terminated using insulation displacement or crimp termination technology on 5.0mm centerlines. The 5.0 PK connector SMT system is available in 2/4/6 positions. It is designed to be terminated to 16 AWG to 24 AWG wire. The 5.0 SMT PK product can meet glow wire test required by IEC 60335-1.

1.2. Qualification

When tests are performed on the subject product line, procedures specified in Figure 2 shall be used. All inspections shall be performed using the applicable inspection plan and product drawing.

1.3. Qualification Test Results

Successful qualification testing on the subject product line was completed between July and Aug 2020. The Qualification Test Report number for this testing is 501-106528.

2. APPLICABLE DOCUMENTS AND FORMS

The following documents form a part of this specification to the extent specified herein. Unless otherwise specified, the latest edition of the document applies. In the event of conflict between the requirements of this specification and the product drawing, the product drawing shall take precedence. In the event of conflict between the requirements of this specification and the referenced documents, this specification shall take precedence.

2.1. TE Connectivity Specifications

114-5292	Application Specification
501-106528	Qualification Test Report

2.2. Commercial Standards and Specifications

EIA-364	Electrical Connector/Socket Test Procedures Including Environmental Classifications
---------	---

2.3. Reference Documents

109-1	General Requirements for Testing
109-197	Test Specifications vs EIA and IEC Test Methods

3. REQUIREMENTS

3.1. Design and Construction

Product shall be of the design, construction, materials and physical dimensions specified on the applicable product drawing.

3.2. Ratings

- A. Voltage Rating: 300V AC
- B. Current Rating: See Figure 1 for applicable current carrying capability. Maximum rated current that can be carried by this product is limited by maximum operating temperature of the housings (105°C) and temperature rise of the housings (30°C). Variables to be considered for each application are: wire size, connector size, contact material, ambient temperature, and printed circuit board design.

Wire Size	16awg	18awg	20awg	22awg	24awg
Position					
Wire Length	29cm	25cm	20cm	16cm	14cm
2P	10A	8A	7A	5A	3A
4P(2row)	8A	6A	5A	3A	2A
6P(2row)	8A	6A	5A	2A	2A

Figure 1 Current rating

Values are based on initial Temperature Rise versus Current Testing and are intended to be a guide in the selection of a connector family. All applications should be tested by the end user. The values listed are per circuit for fully loaded housings being 100% energized. Note: All combinations were not tested, and this chart contains interpolated and extrapolated values, If wire lengths used are less than those listed above, the current carrying ability of the system will be reduced due to less heat being conducted away from the connector. The customer should fully test all applications.

- C. Temperature Rating: -40°C to +105°C (The upper limit of the temperature includes the temperature rising by energized current.)

3.3. Performance Requirements and Test Description

The product should meet the electrical, mechanical and environmental performance requirements specified in Figure 2. All tests shall be performed at ambient environmental conditions otherwise specified.

3.4. Test Requirements and Procedure Summary

Para.	Test Items	Requirements		Procedures
3.3.1	Examination of Product	Meets requirements of product drawing and Application Specification 114-5292.		EIA-364-18. Visual inspection. No Physical damage.
Electrical Requirements				
3.3.2	Termination Resistance (Low Level)	10 mΩ Max. (Initial) 20 mΩ Max. (Final)		EIA 364-23 Subject mated contacts assembled in housing to 20mV Max open circuit at 10mA. See Figure 4.
3.3.3	Dielectric withstanding Voltage	No creeping discharge nor flashover shall occur. 5.0 milliamperes maximum leakage current.		EIA-364-20, Condition I. 2200VAC for 1 minute. Test between adjacent circuits, between the surface of housing and contact of mated connectors.
3.3.4	Insulation Resistance	1000MΩ Min. (Initial) 500MΩ Min. (Final)		EIA-364-21. Impressed voltage 500 V DC. Test between adjacent circuits, between the surface of housing and contact of mated connectors.
3.3.5	Temperature Rising	30°C Max. under loaded specified current or rating current.		EIA-364-70, Method 1. With DC. Measure temperature rising by energized current. Subject measurement must do at the place Of no influence from convection of air. And contacts assembled in housing all of circuits. Stabilize at a single current level until 3 readings at 5 minutes intervals are within 1°C. The thermocouple attached see Figure 4.
Mechanical Requirements				
3.3.6	Crimp Tensile Strength	Wire Size (AWG)	Crimp Tensile (minimum) (N)	EIA-364-8 Operation Speed: 100 mm/min Apply an axial pull-off load to crimped wire of contact secured on the tester. Subject take insulation barrel away.
		24	29.4	
		22	49.0	
		20	58.8	
		18	68.6	
		16	78.4	
3.3.7	Contact Retention Force	39.2N Min. per contact		EIA-364-29 Apply an axial pull-off load to crimped wire. Use the wire of AWG #16 or AWG #18. Operation Speed: 100 mm/min.
3.3.8	Contact Insertion Force	8.82N Max. per contact		EIA-364-5 Measure the force required to insert contact into housing. Operation Speed: 100 mm/min.
3.3.9	Connector Mating Force	Initial & After 25 Cycles 9.8N Max. per contact		EIA 364-9 Measure force necessary to mate specimens with latch disengaged. Operation Speed: 100 mm/min.

3.3.10	Connector Unmating Force	Initial & After 25 Cycles 1.47N Min. per contact	EIA-364-13, Method A. Measure force necessary to mate specimens with latch disengaged. Operation Speed: 100 mm/min.
3.3.11	Durability (Repeated Mate/Unmating)	Check connector mating/unmating force after Durability test.	EIA-364-9. Mate and unmate specimens for 25 cycles at a maximum rate of 500 cycles per hour.
3.3.12	Post Retention Force	29.4N Min.	EIA-364-29 Measure post retention force. Operation Speed: 100 mm/min.
3.3.13	Vibration (Low Frequency)	No discontinuities of 1 microsecond or longer duration. Check LLCR before and after shock test.	EIA-364-28, Test Condition I. Subject mated specimens to 10 to 55 to 10Hz traversed in 1 minute with 1.52 mm maximum total excursion. Two hours in each of 3 mutually perpendicular planes. 100 mA applied.
3.3.14	Mechanical Shock	No discontinuities of 1 microsecond or longer duration. Check LLCR before and after shock test.	EIA-364-27. Accelerated Velocity: 490 m/s (50G) Waveform: Half sine curve Duration: 11 m sec. Velocity Change: 3.4 m/s Number of Drops: 3 drops each to normal and reversed directions of X.Y and Z axes, totally 18 drops.
3.3.15	Connector Locking Strength	29.4N Min.	EIA-364-98. Measure connector locking strength. Operation Speed: 100 mm/min.
3.3.16	Contact Mating Force	Initial & After 25 Cycles. 9.8N maximum per Contact.	EIA 364-9 Measured by gauge tab (see Fig.5) Operation Speed: 100 mm/min.
3.3.17	Contact Unmating Force	Initial: 0.34N Min. After 25 Cycle: 0.25N Min.	EIA 364-9 Measured by gauge tab (see Fig.5) Operation Speed: 100 mm/min.
ENVIRONMENTAL			
3.3.18	Resistance to Cold	Check LLCR before and after shock test.	EIA-364-59 Mated connectors, -40±2°C, 96 hours.
3.3.19	Thermal Shock	Check LLCR before and after shock test.	EIA-364-32, Test Condition VII. Subject mated specimens to 25 cycles between -55 and 105°C with 30 minutes dwells at temperature extremes and 5 minutes transition between temperatures. The measurement is held after being left indoor for 3 hours.
3.3.20	Humidity-Temperature Cycling	Check LLCR, Dielectric withstanding voltage and Insulation resistance after shock test.	EIA-364-31, Method III. Subject specimens to 10 cycles (10 days) between 25 and 65°C at 90 to 95% RH, Cold shock -10°C (not) performed. The measurement is held after being left indoor for 3 hours.

3.3.21	Salt Spray	Check LLCR before and after shock test. No corrosion influence performance.	EIA-364-26. Subject mated specimens to 5±1% salt concentration for 48 hours. The measurement is held after being left indoor for 3 hours.
3.3.22	Temperature Life (Heat Aging)	Check LLCR before and after shock test.	EIA-364-17, Method A, Test Condition 4, Test Time Condition C. Subject mated specimens to 105±2°C for 96 hours. The measurement is held after being left indoor for 3 hours.
3.3.23	Solderability	Wet Solder Coverage: 90 % Min.	TEC-109-11 Solder Temperature: 245 ± 5°C. Immersion Duration: 3 ± 0.5 seconds.
3.3.24	Resistance to Soldering Heat	No physical damage shall occur.	TE-109-201, condition B. Test connector on PCB. SMT Peak Temperature: 260 +0/-5°C 20-40S, 3times
3.3.25	Ammonia	Check LLCR before and after shock test. No corrosion influence performance.	Subject mated specimens in atmosphere that rated 25 mL/L of 3% NH ₃ for 7 hours.
3.3.26	Hydrogen sulfide.	Check LLCR before and after shock test. No corrosion influence performance.	Subject mated specimens to 3 ± 1 ppm H ₂ S gas concentration maintained at 40 ± 2°C for 96 hours.
3.3.27	Glow Wire Test	Perform visual check and take picture after the test.	IEC 60695-2-11 and IEC 60335-1 No flame or Te - Ti < 2s. Temperature: 750. Duration of glow tip application Ta: 30s.

Figure 2



NOTE

Shall meet visual requirements, show no physical damage, and meet requirements of additional tests as specified in the Product Qualification and Requalification Test Sequence shown in Figure 3 & 4.

3.5. Product Qualification and Requalification Test Sequence

Test or Examination	Test Group (a)																	
	1	2	3	4	5	6	7	8	9	10	11	12	13	14	15	16	17	18
	Test Sequence (b)																	
Initial Examination	1	1	1	1	1	1	1	1	1	1	1	1	1	1	1	1	1	1
LLCR	3,6	2,5,7		2,4	2,4							2,4			2,4	2,4	2,4	2,4
Dielectric Withstanding Voltage			3,7															
Insulation resistance			2,6															
Temperature Rise vs. Current						2												
Sinusoidal Vibration		4																
Mechanical Shock		6																
Durability	5	3																
Post Retention Force								2										
GWT							2											
Solderability									2									
Resistance to Soldering Heat										2								
Connector Mating Force	2,7																	
Connector Unmating Force	4,8																	
Crimping Strength											2							
Connector Locking Strength												5						
Contact Insertion Force													2					
Contact Retention Force													3					
Contact Mating Force														2				
Contact Unmating Force														3				
Thermal Shock			4	3														
Humidity/Temperature Cycling			5		3													
Temperature Life (Heat Aging)												3						
Salt Spray															3			
Hydrogen Sulfide																3		
Ammonia																	3	
Resistance to Cold																		3
Final Examination	9	8	8	5	5	3				3	3		4	4	5	5	5	5

Figure 3



NOTE

(a) See paragraph 4.2.

(b) Numbers indicate sequence in which tests are performed.

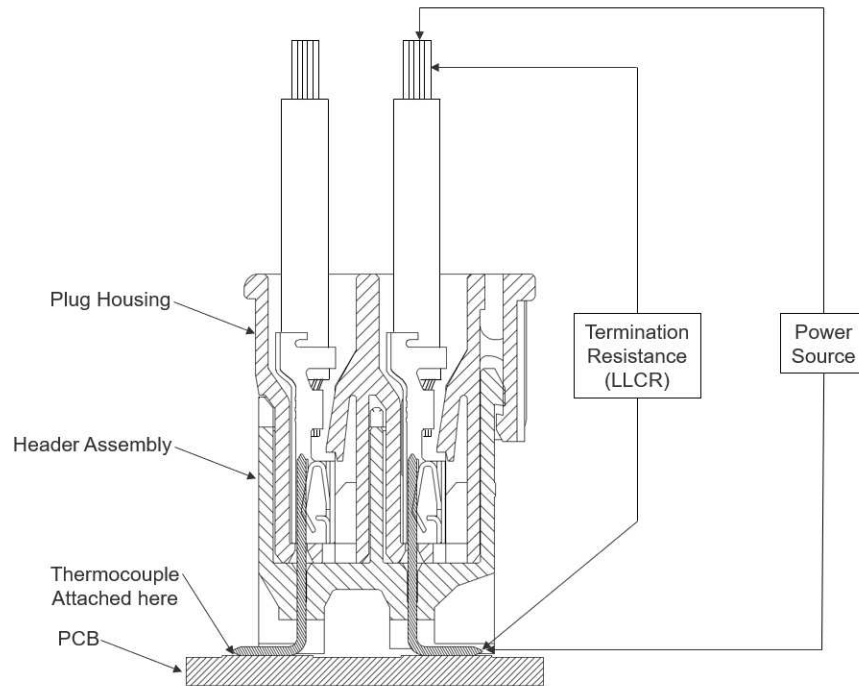

Figure 4 LLCR Measurement Points (Subtract Wire Bulk) and Temperature Rise Measurement Points

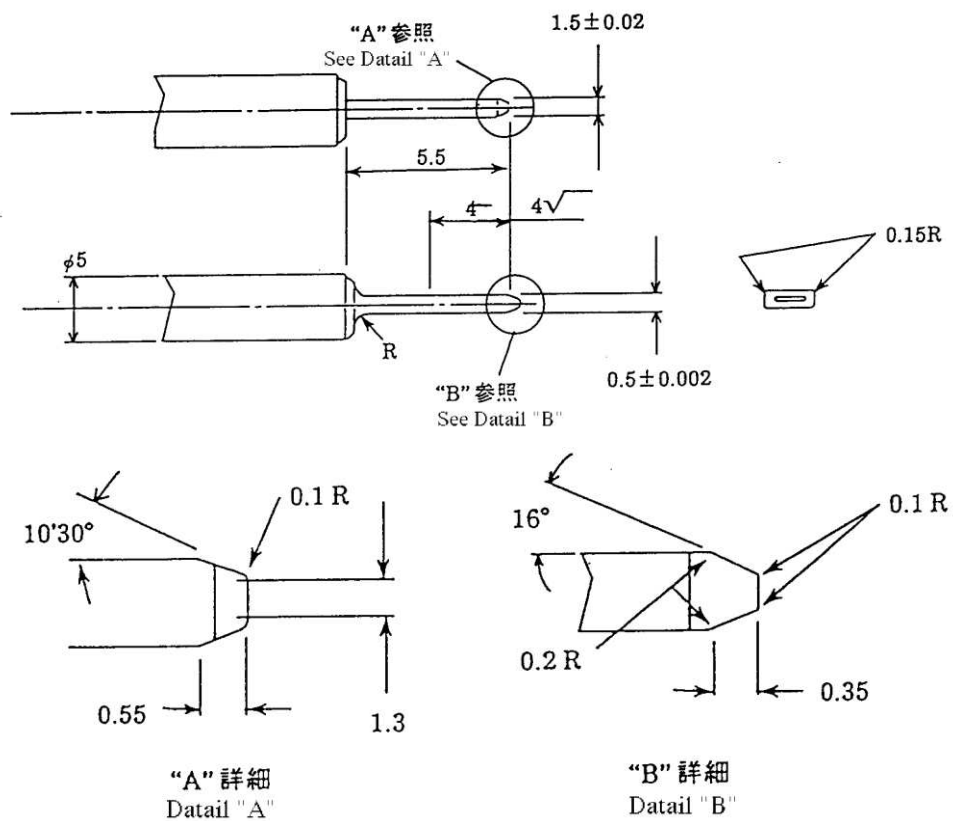

Figure 5 Gage Design for Contact Mating/Unmating Force Tests

3.6. Part Number List

Description	Part Number	Remark
Receptacle Contact(L)	X-1376347-X	AWG #20 ~ #16
Receptacle Contact(M)	X-1376348-X	AWG #24 ~ #20
Header Assembly	X- 2371337-X	2P (Single Row)
	X- 2371335-X	4P (Double Row)
	X- 2371336-X	6P (Double Row)
Plug Housing	X-2371224-X	2P (Single Row)
	X-1376392-X	4P (Double Row)
	X-1376393-X	6P (Double Row)

Figure 6

4. QUALITY ASSURANCE PROVISIONS

4.1. Test Conditions

Unless otherwise specified, all the tests shall be performed in any combination of the following test conditions shown in Figure 7.

Temperature	15°C – 35°C
Relative Humidity	45% – 75%
Atmospheric Pressure	86.6 – 106.6 kPa

Figure 7

4.2. Qualification Testing

A. Specimen Selection

Specimens shall be prepared in accordance with applicable instruction sheets and shall be selected at random from current production.

B. Test Sequence

Qualification inspection shall be verified by testing specimens as specified in Figure 2 and 3 **Error! Reference source not found..**

4.3. Requalification Testing

If changes significantly affecting form, fit or function are made to the product or manufacturing process, product assurance shall coordinate requalification testing, consisting of all or part of the original testing sequence as determined by development/product, quality and reliability engineering.

4.4. Acceptance

Acceptance is based on verification that the product meets the requirements in Figure 2. Failures attributed to equipment, test setup or operator deficiencies shall not disqualify the product. If product failure occurs, corrective action shall be taken and specimens resubmitted for qualification. Testing to confirm corrective action is required before resubmittal.

4.5. Quality Conformance Inspection

The applicable quality inspection plan shall specify the sampling acceptable quality level to be used. Dimensional and functional requirements shall be in accordance with the applicable product drawing and this specification.