

SOLARLOK PV BAR Junction Box

1. SCOPE

1.1. Content

This specification covers performance, tests and quality requirements for the TE Connectivity SOLARLOK PV BAR Junction Box used for distributing energy captured by solar panels used in the Photovoltaic (PV) industry.

The corresponding connecting cables including connectors are fixed with the terminal box. The connectors at the cables are marked with their polarity. It is important to take care of the polarity before connecting. This connector is to be used only to interconnect firmly fixed cables!

The junction box allows electrical connection between Photovoltaic (PV) panels and allows connection of the foils exiting the solar panel. This connection is made by soldering the foil to the rail whose interface surface is in a horizontal position and then potting.

The cover of the junction box is used for basic protection of junction box not to be exposed since all the live parts are completely encapsulated by potting material.

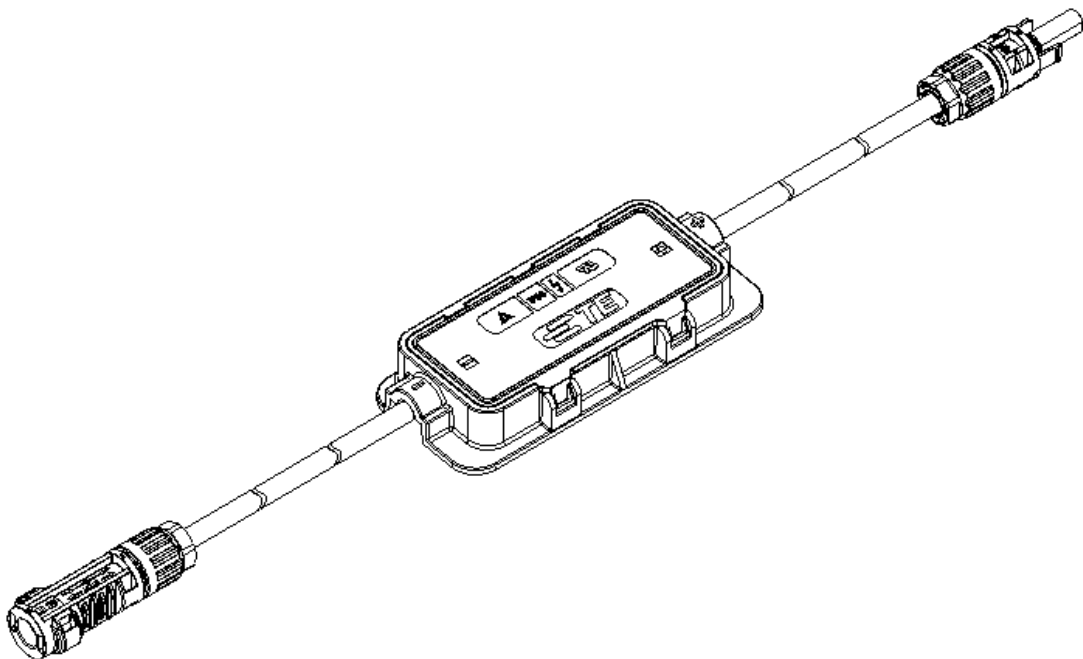

Figure 1: Junction Box Overview

1.2. Qualification

When tests are performed the following specified specifications and standards shall be used. All inspections shall be performed using the applicable inspection plan and product drawing.

2. APPLICABLE DOCUMENTS

The following documents form a part of this specification to the extent specified herein. In the case of a conflict between the requirements of this specification and the product drawing or of conflicts between the requirements of this specification and the referenced documents, this specification shall take precedence.

2.1. TE Connectivity Documents

- 114-137167: Application Specifications (SOLARLOK PV BAR Junction Box)
- 501-137167: Qualification Test Report (SOLARLOK PV BAR Junction Box)
- 404-74000-1: Model Code for SOLARLOK System

2.2. Commercial Standard

- EIA-364: Electrical Connector/Socket Test Procedures Including Environmental Classifications
- IEC 60512: Electromechanical Components For Electronic Equipment; Basic Testing Procedures and Measuring Methods Part 1: General
- IEC 60529: Degrees of Protection Provided by Enclosures (IP Code)
- IEC 61215: Crystalline silicon Photovoltaic (PV) Modules - Design Qualification and Type Approval
- IEC 61646: Thin-film Photovoltaic (PV) Modules - Design Qualification and Type Approval
- IEC 60068: Electrical engineering, Environmental testing
- UL1703: Flat-Plate Photovoltaic Modules and Panels
- Safety class II
- IEC 62790: Junction boxes for photovoltaic modules, TÜV Rheinland certificate: RXXXXXX
- UL 3730: Safety for Photovoltaic Junction Boxes, UL file: E226440-20160318 & E329994-20160318

3. REQUIREMENTS

3.1. Design and Construction

Product shall be of the design, construction and physical dimensions specified on the applicable product drawing.

3.2. Materials

Materials used in the construction of this product shall be as specified on the applicable product drawing.

3.3. Ratings

- System Ratings:

Model code	Max working Voltage	Voltage (UL)	Voltage (TÜV)	Max impulse Voltage	Current
PVBAR4GAR3TA	120 V	1000 V dc	1000 V dc	12000 V dc	15 A
PVBAR4GAY3TA	120 V	1500 V dc	1500 V dc	16000 V dc	15 A
PVBAR4GAR3FA	120 V	1000 V dc	1000 V dc	12000 V dc	8.5 A
PVBAR4GAY3FA	120 V	1500 V dc	1500 V dc	16000 V dc	8.5 A
PVBAR4GBR3TA	120 V	1000 V dc	1000 V dc	12000 V dc	15 A
PVBAR4GBY3TA	120 V	1500 V dc	1500 V dc	16000 V dc	15 A
PVBAR4GBR3FA	120 V	1000 V dc	1000 V dc	12000 V dc	8.5 A
PVBAR4GBY3FA	120 V	1500 V dc	1500 V dc	16000 V dc	8.5 A

Table 1: System rating

- Cable connector: 35 A Max. for 4.0 mm² / 12 AWG
- Cable size 4.0 mm² / 12 AWG
- Operating temperature -40 °C 85 °C
- Storage temperature -40 °C 85 °C
- IP Code IP65 & IP68 (1 m, 24 h)
- Pollution degree 1 (Inside of the junction box)

Diodes

Diode	Maximum rated voltage	Maximum rated current	Reverse current
SL1515B	40 V dc	20 A dc	30 A
SL1515E	45 V dc	20 A dc	30 A
SL1515F	45 V dc	20 A dc	30 A
F1200D	150 V dc	12 A dc	30 A
SL2020A*	50 V dc	20 A dc	30 A
SL2020B*	50 V dc	20 A dc	30 A

Table 2: Diodes

**) These diodes are not yet released for production, currently under approval (by TÜV Rheinland).*

Cables approved for use by TÜV Rheinland:

Manufacturer	TÜV Rheinland certificate
TE Connectivity	R??????

Backsheet approved for use by TÜV Rheinland:

Manufacturer	TÜV Rheinland certificate
Toyo Aluminium K.K.	R??????

3.4. Performance and Test Description

Product shall be designed to meet the electrical, mechanical and environmental performance requirements specified in Paragraph 3.5. Unless otherwise specified, all tests shall be performed at ambient environmental conditions per IEC62790 and UL3730.

The test and sequence describe in 3.5 are tested internally by TE Connectivity.

3.5. Test Requirements and Procedures Summary

3.5.1 GENERAL INSPECTIONS			
No.	Test Description	Requirement	Procedure According
3.5.1.1	Marking	The marking shall be indelible and easily legible.	Visual examination IEC62790
3.5.1.2	Technical documentation	Information according to 4.2.3 and additional information	Visual examination IEC62790
3.5.1.3	Approval of attached components	Components shall comply with the relevant standards.	Visual examination Per IEC62790
3.5.2 Material Test			
No.	Test Description	Requirement	Procedure According
3.5.2.1	Resistance against ageing	The sealing characteristic shall not be impaired; Compliance shall be checked by verifying the IP-code according to EN 60529.	Accelerated ageing in oven. Gaskets, e.g. separate polymer seals, shall be stored in a heating cabinet for 240 h at (100 ± 5) °C and subsequently cooled down for 16 h at ambient temperature. IEC62790
3.5.3 Constructional Requirements			
No.	Test Description	Requirement	Procedure According
3.5.3.1	Degree of protection	No ingress of dust and water	Test IP-code per IEC 60529 Gaskets shall be aged IEC62790

3.5.3.2	Mold Stress-Relief Distortion Test	Not cause softening of the material as determined by handling immediately after the conditioning, nor shall there be shrinkage, warpage, or other distortion as judged after cooling to room temperature	One sample of the complete equipment (in the case of an enclosure) or the part under consideration, is to be placed in a full draft circulating air oven maintained at a uniform temperature at least 10°C higher than the maximum temperature of the material measured under actual operating conditions, but not less than 70 °C in any case. The sample is to remain in the oven for 7 hours. After its careful removal from the oven and return to room temperature, the sample is to be investigated UL Subject 3730 §25
3.5.4 Mechanical Tests			
No.	Test Description	Requirement	Procedure According
3.5.4.1	Terminations and connection methods	Fix position of terminals	Visual examination, of protection for lead or cable IEC62790
		Requirements of relevant clauses shall be fulfilled.	Mechanical test of suitability of terminals and connections IEC62790
3.5.4.2	Cord anchorage	a) Elongation less than 2 mm b) Torsion shall not exceed 45 °.	Pull- and Torsion Test Pull the cable for duration of 1 s, 50 times with a force of 30N, afterwards apply a torque of 0.1 Nm for 1 min. IEC62790
3.5.4.3	Mechanical strength at lower temperatures	No damage, which may impair function	Placed on a steel of 20 mm thickness for 5 h in -40 °C, then knock 4 uniformly distributed positions with 1 joule evenly on specimen IEC62790
3.5.4.4	Retention on the mounting surface	No loosening or displacement of Specimen; Insulation resistance not less than 400 MΩ	Pre-aged at TC 200 and Damp heat test respectively, A force of 40 N shall be gradually increased and applied for 30 min in each direction parallel to the mounting surface and perpendicular to the mounting surface. Wet leakage current test according to IEC62790
3.5.4.5	Strain relief test	Without transfer of the force to the electrical connection, or damage to the lead or cable, and its connecting means; Without damage to the connector, the junction box, or the mounting of the connector to the junction box, or separation of the	A lead or cable for connection to external wiring, or a lead or cable terminated at both ends on the shall withstand for 1 min a force of 89 N applied in any direction permitted by the construction; A separable connector not enclosed

		two mating connectors.	by a wiring compartment, and such connector's joining to its mating connector shall withstand for 1 min a force of 89 N applied in any direction permitted by the construction, either directly or through any wire or cable attached to the mating connector UL Subject 3730 §26
3.5.4.6	Crush Test	Without resulting in any of the following: a) Reduction of spacing below the minimum acceptable values. b) Making bare live parts or internal wiring accessible to contact. c) Such breakage, cracking, rupture, and the like as to produce an adverse effect on the insulation. d) Producing any other condition that would increase the likelihood of electric shock or fire, or both, during use of the equipment.	The junction boxes are to be supported on the mounting side by a fixed rigid supporting surface, in the position that is recommended by the manufacturer. Crushing force is to be applied to the exposed surfaces of the junction boxes for 1 min. The compression force is to be applied by flat surfaces each 102 by 254 mm. Each force applicator is to exert 45.4 kg on the sample. UL 3730 §27
3.5.4.7	Wiring Compartment Securement Test	The tensile force required to separate a wiring compartment or box from a module shall not be less than 35 lb. (155.7 N) or 4 times the wiring compartment or box weight, whichever is greater	Samples are to be tested in the as-received condition, after being conditioned in accordance with Temperature Cycling Test and after conditioning in accordance with Humidity Test UL1703 § 42
3.5.5 Electrical Tests			
No.	Test Description	Requirement	Procedure According
3.5.5.1	Dielectric strength (r.m.s. withstand voltage)	No flashover or breakdown of voltage	Apply an r.m.s. withstand voltage (50/60 Hz) with a r.m.s.-value of 2000 V + 4 times rated voltage for 1 min. IEC62790
3.5.5.2	Dielectric strength (impulse withstand)	No flashover or breakdown of voltage	Impulse withstand test with a voltage having a 1,2/50 μ s waveform according to EN 60060-1 with three impulses of each polarity and an interval of at least 1s between pulses. IEC62790
3.5.5.3	Wet leakage current test	Insulation resistance shall be not less than 400 M Ω	A shallow trough or tank of sufficient size to enable the module with frame to be placed in the solution in a flat, horizontal position, it shall contain a water/wetting agent solution meeting the following requirements: resistivity: 3500 Ω .cm or less surface tension: 0.03 N.m ⁻¹ or less temperature: 22 °C \pm 3 °C applied a 500V or the maximum rated system voltage of the module (Per 10.15 of IEC 61215)

			Hold this voltage for 2 min. IEC62790
3.5.5.4	Bypass diode thermal test	<ul style="list-style-type: none"> a) the diode T_j shall not exceed the diode manufacture maximum rating T_j b) no evidence of major visual defects; c) The diode shall be still operational. 	Heat the specimen to 75 ± 5 °C. Apply a current to the specimen equal to the rated current ± 2 % of the junction box. After 1 h, measure the temperature of each bypass diode and at the insulating material, where the highest temperature is expected. Increase the applied current to 1,25 times of the rated current of the junction box while maintaining the box temperature at 75 ± 5 °C. Maintain the current flow for 1 h. IEC 62790
3.5.5.5	Temperature test	<p>No part shall attain a temperature that would:</p> <ul style="list-style-type: none"> a) Ignite materials or components; b) Cause the temperature limits of surfaces, materials, or components as described in Table 22.1, to be exceeded; c) Cause the Relative Thermal Index – 20 °C of polymeric materials to be exceeded; or d) Cause creeping, distortion, sagging, charring or similar damage to any part of the product, if such damage or deterioration may impair the performance of the product under the requirements of this Outline. 	Test the junction box at equilibrium while conducting rated current in the forward direction (minus to plus) through the tabbing (diodes shall be replaced in the circuit with representative tabbing); UL 3730 §21
3.5.6 Environment Tests			
No.	Test Description	Requirement	Procedure According
3.5.6.1	Damp heat test	No visible damages, which could impair function or safety	Test temperature: 85 ± 2 °C Relative humidity: 85 ± 5 %; 5N force is applied vertically; Test duration: 1 000 h. IEC62790
3.5.6.2	Humidity-freeze test	No evidence of major visual defects	From 85 ± 2 °C, RH 85 ± 5 % to -40 ± 2 °C; 20 h min at upper, 0.5 h max at lower; The transfer time between upper and lower temperature shall not exceed 100 °C/h; 10 cycles IEC62790
3.5.6.3	Thermal cycle test	No visible damages, which could impair function or safety	From -40 ± 2 °C to 85 ± 2 °C; The transfer time between upper and lower temperature shall not exceed 100 °C/h; Rated current is applied during the temperature from 25 °C to 85 °C. 200 cycles. IEC62790
3.5.6.4	Salt Mist Corrosion Test	a) No corrosion influence	Salt mist test according to any one of

		<p>performance</p> <p>b) The insulation resistance shall not be less than 400 MΩ</p> <p>c) The overall resistance shall not increase by more than 5 % of the initial value.</p>	<p>the severities included in IEC 60068-2-52, severity 3</p> <p>Per IEC 61701</p>
3.5.6.5	Annex B test	No visible damages, which could impair function or safety	<p>Humidity- freeze test: 24 hours;</p> <p>Dry heat test: 48 hours;</p> <p>Thermal shock test: 5 cycles;</p> <p>Damp heat test: 1000 hours;</p> <p>IEC62790</p>

Table 3: Test overview

3.6 Qualification and Requalification Test Sequences

Test or Examination		Test Group									
		A	B	C	D	E	F	G	H	I	J
		Test Sequence (a)									
3.5.1.1	Marking	1									
3.5.1.2	Technical documentation	2									
3.5.1.3	Approval of attached components	3									
3.5.2.1	Resistance against ageing				3						
3.5.3.1	Degree of protection				1, 4	1					
3.5.3.2	Mold Stress-Relief Distortion Test			2							
3.5.4.1	Terminations and connection methods		1								
3.5.4.2	Cord anchorage		2								
3.5.4.3	Mechanical strength at lower temperatures		3								
3.5.4.4	Retention on the mounting surface					8	6				
3.5.4.5	Strain relief test		4	3							
3.5.4.6	Crush Test		5								
3.5.4.7	Wiring Compartment Securement Test		6			10		7			
3.5.5.1	Dielectric strength (r.m.s. withstand voltage)					2, 5	1, 4	1, 5		1, 4	
3.5.5.2	Dielectric strength (impulse withstand)					6					
3.5.5.3	Wet leakage current test				2,5	3, 7, 9	2, 5, 7	2, 6	2	2, 5	2
3.5.5.4	Bypass diode thermal test								1		
3.5.5.5	Temperature test			1							
3.5.6.1	Thermal cycle test (Test cycle 50)							3			
3.5.6.2	Damp heat test						3				
3.5.6.3	Humidity-freeze test							4			
3.5.6.4	Thermal cycle test (Test cycle 200)					4					
3.5.6.5	Salt Mist Corrosion Test									3	
3.5.6.6	Annex B test										1

Table 4: Qualification and Requalification Test Sequences

- (a) Numbers indicate the sequence in which the tests are performed.
- (b) Test Group A, B are single tests, for others tests to be performed consecutively in order

3.7 Periodic Verification Test Sequences

Test or Examination		Test Group						
		K	L	M	N	O	P	Q
		Test Sequence (a)						
-	Visual examination	1, 6	1, 5	1, 7	1, 12	1, 9	1, 8	1, 4
3.5.2.1	Resistance against ageing			4				
3.5.3.1	Degree of protection			2, 5	2			
3.5.3.2	Mold Stress-Relief Distortion Test		3					
3.5.4.2	Cord anchorage	2						
3.5.4.4	Retention on the mounting surface				9	7		
3.5.4.5	Strain relief test	3	4					
3.5.4.6	Crush Test	4						
3.5.4.7	Wiring Compartment Securement Test	5			10		7	
3.5.5.1	Dielectric strength (r.m.s. withstand voltage)				3, 6	2, 5	2, 5	
3.5.5.2	Dielectric strength (impulse withstand)				7			
3.5.5.3	Wet leakage current test			3, 6	4, 8, 11	3, 6, 8	3, 6	3
3.5.5.4	Bypass diode thermal test							2
3.5.5.5	Temperature test		2					
3.5.6.2	Damp heat test					4		
3.5.6.3	Humidity-freeze test						4	
3.5.6.4	Thermal cycle test (Test cycle 200)				5			

Table 5: Periodic Verification Test Sequences

(a) Numbers indicate the sequence in which the tests are performed.

3.8 Inspection Sample Size and Frequency of Periodic Verification Tests

Test Group	Sample Size	Test Frequency
K	5 pieces	Every 6 months
L	5 pieces	Every 6 months
M	5 pieces	Every 6 months
N	5 pieces	Every 12 months
O	5 pieces	Every 12 months
P	5 pieces	Every 12 months
Q	5 pieces	Every 6 months

Table 6: Inspection Sample Size and Frequency of Periodic Verification Tests

4. QUALITY ASSURANCE PROVISIONS

4.1. Qualification Testing

A. Specimen Selection

Specimens shall be prepared in accordance with applicable Instruction Sheets and shall be selected at random from current production. All test groups shall each consist of some random junction assemblies as highlighted.

B. Test Sequence

The samples shall be prepared in accordance with product drawings. They shall be selected at random from current production.

4.2. Requalification Testing

If changes significantly affecting form, fit or functions are made to the product or manufacturing process, product assurance shall coordinate requalification testing, consisting of all or part of the original testing sequence as determined by development/product, quality and reliability engineering.

4.3. Acceptance

Acceptance is based on verification that the product meets the requirements of Table 1. Failures attributed to equipment, test setup or operator deficiencies shall not disqualify the product. If product failure occurs, corrective action shall be taken and specimens resubmitted for qualification. Testing to confirm corrective action is required before re-submittal.

4.4. Quality Conformance Inspection

The applicable quality inspection plan shall specify the sampling acceptable quality level to be used. Dimensional and functional requirements shall be in accordance with the applicable product drawing and this specification. Bulk wire resistance shall be subtracted from resistance readings.

Annex A

Documentation Change Record

Rev	Clause	Page	Change Description	DATE	DWN	APRD
A			New Release	06MAY2016	YZ	LW
A1	3.3	4- 5	Update model code F1200D	12AUG2016	YZ	LW
B	3.3	4- 5	Update model code SL2020	2AUG2018	MZ	OL
C	§3.3; §3.7; §3.8	10	Added Periodic Verification Test and added table.	25JUN2018	MZ/CvS	OL
D	§3.3	3	Updated according TÜV	26 August 2019	MZ/CvS	JS
D1	N/A	all	Added license holder in footer	11 September 2019	CvS	JS
D2	§2.2 §3.4		Update standard specifications, added clarification on TE Connectivity testing	24 September 2019	CvS	JS

Table 7: revision History