

1.0 SCOPE

1.1. Content:

This specification covers performance, tests and quality requirements Din Rail Screw type Protective Conductor Terminal Block connector according to IEC60947-7-2 standard. Applicable product descriptions and part numbers are as shown on product drawing.

1.2. Qualification:

When tests are performed on the subject product line, procedures specified shall be used. All inspections shall be performed using the applicable inspection plan and product drawing.

2.0 APPLICABLE DOCUMENTS

The following documents form a part of this specification to the extent specified herein. Unless otherwise specified, the latest edition of the document applies. In the event of conflict between the requirements of this specification and the product drawing, the product drawing shall take precedence. In the event of conflict between the requirements of this specification and the referenced documents, this specification shall take precedence.

2.1 TE Connectivity Documents:

114-137172: Application Specification for Din Rail Screw type Terminal Block.

501-137173: Qualification Test Report for Din Rail Screw type Protective Conductor Terminal Block

3.0 REQUIREMENTS

3.1 Design and Construction

Product shall be of the design, construction and physical dimensions specified on the applicable product drawing.

3.2 Materials

Materials used in the construction of this product shall be as specified on the applicable product drawing.

3.4 Ratings

A. Voltage: see table 10

B. Current: see table 10

C. Wire Size: see table 10

D. Operating Temperature: -40 to 105°C

E. Storage Environment:

Temperature: - 25°C to 40°C Relative humidity: 15%-70%

3.5 Performance and Test Description

Product is designed to meet the electrical, mechanical and environmental performance requirements. Unless otherwise specified, all tests shall be performed in the room temperature (5~35°C), relative humidity (45~85%), air pressure (86~106kPa), and special case temperature (18~22°C), relative humidity (60~70%), unless otherwise specified.

3.6 Test Requirements and Procedures Summary

3.6.1 Examination:

Test Description	Requirement	Procedure
Examination of the product	Meets visual requirements.	Visual inspection per product drawing. Per EIA-364-18

3.6.2 ELECTRICAL

Test Description	Requirement	Procedure
Impulse Withstanding Voltage test	There shall be no unintentional disruptive discharge during the tests.	Each test shall be carried out on five adjacent terminal blocks wired and installed on a metal support. The test equipment shall be calibrated to produce a 1,2/50 μ s waveform as defined in IEC 61180. The output is then connected to the equipment to be tested and the impulse applied five times for each polarity at intervals of 1 s minimum. Apply the impulse Voltage value(refer to the value of the sea level list of table 12 of IEC60947-1) according to table 10 between: 1>the protective conductor terminal blocks and the terminal block. Detail connections refer to figure 1 Per IEC60947-7-2 section 8.4.3
Voltage drop	Before the tests according to a), b), c) , the voltage drop U _{cc} shall not exceed 3,2 mV;and the voltage drop U _{cs} shall not exceed 6,4 mV with the exception of test c) for which the voltage drop test is performed after the test only, if steel supports with a chromated surface are used. If the measured value of U _{cc} or U _{cs} exceeds 3,2 mV or 6,4 mV respectively, the voltage drop is determined on each individual clamping unit separately, which shall not exceed 1,6 mV or 4,8 mV respectively. After the tests according to a), b) and c), voltage drops U _{cc} and U _{cs} shall not exceed 4,8 mv or 9,6 mV respectively, or 150 % of the values measured before the tests, whichever is the lower.	The voltage drop shall be verified: a) before and after the test of mechanical strength of clamping units ; b) before and after the temperature-rise test ; c) before and after the short-time withstand current test; The voltage drop is measured on each terminal block as Indicated in Figure 2 . The measurement is made with a direct current of 0,1 times the value given in Table 4 or Table 5 of IEC60947-7-1 Per IEC60947-7-2 section 8.4.4
Short-time withstand current test	At the end of the test, continuity shall exist on the test sample assembly and the terminal blocks shall not show any cracking, breakage or other critical damage. After cooling down to ambient temperature and without any change in the arrangement, the terminal block shall pass the voltage drop test.	A terminal block shall be capable of withstanding for 1 s the short-time withstand current which corresponds to 120 A/mm ² of its rated cross-section, The maximum short-time withstand currents allocated to the rail profiles in Table A.1 shall be considered as limit values. The support rail should be copper rail. The test current is applied once through the current path 1-1 and then through the current path 2-2, in accordance with Figure 3 . The test is performed on one terminal block installed according to the manufacturer's instructions. The tightening torque shall be in accordance with Table 4 of IEC 60947-1 or alternatively in accordance with the higher torque value stated by the manufacturer (see table 10). If the rated cross-section is below 10 mm ² (AWG 8), the conductors shall be solid. For rated cross-sections equal to or higher than 10 mm ² (AWG 8), the conductors shall be rigid stranded. Per IEC60947-7-2 section 8.4.6

Test Description	Requirement	Procedure
Temperature rise	The temperature rise should be 45°C Max. Pass voltage drop test.	<p>This test is only applicable for protective conductor terminal blocks with PEN function equal to and above 10 mm² (AWG 8) rated cross-section. To this effect, the thermal rated current values allotted to the rail profiles in Table A.1 are to be seen as limit values. The tightening torque shall be in accordance with Table 4 of IEC 60947-1 or alternatively in accordance with the higher torque value stated by the manufacturer (see table 10). The minimum length of each conductor shall be 1 m for rated cross-sections up to and including 10 mm² (AWG 8), and 2 m for larger rated cross-sections. The test shall be made with PVC-insulated conductors having the rated cross-section. The conductors shall be rigid stranded. During the test, screws of clamping units shall not be re-tightened. The test circuit shall be located horizontally on a wooden surface as shown in Figure 5 (e.g. table top or floor), the terminal blocks being securely fixed to this surface and the conductors lying freely on it. The test is made with a.c. single-phase current as given in Table 4 or Table 5 of IEC60947-7-1 according to the rated cross-section, and is continued until steady temperature is reached. A variation of less than 1 K between any two out of three consecutive measurements made at an interval of 5 min is considered as steady temperature. For multi-tier terminal blocks, the test is made either with an a.c. single-phase current as given in Table 4 or Table 5 of IEC60947-7-1, or with the conventional free air thermal current (/th) specified by the manufacturer. The current and wire size refer to table 10. Two different test groups shall be provided:</p> <p>a) five insulated protective conductor terminal blocks shall be arranged adjacently without support shown as figure 5(group a). The temperature shall be measured on the middle protective conductor terminal block;</p> <p>b) five protective conductor terminal blocks shall be arranged adjacently on their copper support shown as figure 5(group b), the two outer protective conductor terminal blocks being linked through their support. The temperature shall be measured on the two outer protective conductor terminal blocks.</p> <p>Per IEC60947-7-2 section 8.4.5</p>

3.6.3 Mechanical

Test Description	Requirement	Procedure
Attachment of the terminal block on its support	During the test, no terminal block shall work free from its rail or support, nor suffer any other damage.	<p>The test shall be made on two clamping units at the centre terminal block out of five terminal blocks mounted as in normal use on the appropriate support according to the manufacturer's instructions.</p> <p>A steel pin of 150 mm length and of a diameter as specified in Table 3 is clamped successively in each clamping unit. The tightening torque shall be in accordance with Table 4 of IEC 60947-1 or, alternatively, in accordance with the higher torque value stated by the manufacturer (see table 10). A force corresponding to the values of Table 1 is applied to the pin regularly and without shocks at a distance of 100 mm from the centre of the clamping unit, according to Figure 6. Per IEC60947-7-1 section 8.3.2</p>

<p>Mechanical strength of clamping units</p>	<p>During the test, clamping units and terminals shall not work loose and there shall be no damage, such as breakage of screws or damage to the head slots, threads, washers or stirrups that will impair the further use of the screwed connections. Pass the voltage drop test</p>	<p>Tests shall be made on two clamping units at the centre terminal block out of five terminal blocks mounted as in normal use on the appropriate support according to the manufacturer's instructions with the appropriate type of conductor having the maximum cross-section. The conductor shall be connected and disconnected five times. For screw-type terminals, the tightening torque shall be in accordance with Table 4 of IEC 60947-1 or 110 % of the torque specified by the manufacturer (see table 10), whichever is the greater. The test shall be conducted on two separate clamping units. Each time the clamping screw or nut is loosened, a new conductor shall be used for each tightening test. After Voltage drop Ucc tested, Subsequently test Voltage drop Ucs, then mounted and dismantled the terminal blocks from the support rail for five times, at the end of the test, the protective terminal blocks shall pass the voltage drop test . Per IEC 60947-7-2 section 8.3.3.1</p>
<p>Damage to and accidental loosening of conductors of a terminal block- flexion test(Secureness test)</p>	<p>During the test, the conductor shall neither slip out of the terminal nor break near the clamping unit. Pass pullout force test</p>	<p>Each test shall be carried out on two clamping units of one terminal block shown as figure 7. The tightening torque shall be in accordance with Table 4 of IEC 60947-1 or alternatively in accordance with the higher torque value stated by the manufacturer. The tests shall be made with the type (rigid and/or flexible) and the number of conductors stated by the manufacturer as follows: – with the different types of conductor of the specified smallest cross-section (only one conductor connected); – with the different types of conductor of the specified rated cross-section (only one conductor connected); Test value for secureness test should follow table 2 Per IEC 60947-7-2 section 8.3.3.2</p>
<p>Pull out test(b) (Conductor tensile force test)</p>	<p>During the test, the conductor shall neither slip out of the terminal nor break near the clamping unit.</p>	<p>The pull out force (refer to table 2) should be applied in one smooth and continuous application, for 1 min, in the direction of the axis of the conductor. Using the max. size and Min. size wire(solid and stranded) refer to table 10 , the wire should be stranded for 10mm²(8AWG) and larger size. The screws should not be tightened again after flexion test. (Per IEC60947-7-1 section 8.3.3.3)</p>
<p>Rated cross-section and rated connecting capacity</p>	<p>The required wire can be inserted unhindered in the opened clamping unit and be connected.</p>	<p>The test shall be carried out on each clamping unit of one terminal block. For conductors of the rated cross-section and for terminal blocks with a rated connecting capacity up to 35 mm², one conductor of the two next smaller cross-sections shall be inserted unhindered in the opened clamping unit and be connected. The wire size should refer to table 10. Per IEC60947-7-1 section 8.3.3.4</p>
<p>Verification of rated cross-section (special test with gauges)</p>	<p>can inserted freely into the full depth of terminal block aperture</p>	<p>The test shall be carried out on each clamping unit of one terminal block. The measuring section of the gauge shall be able to penetrate freely into the terminal aperture to the full depth of the terminal (see also note to Table 7). Alternatively, the test can be carried out by inserting the largest conductor of type and rated cross-section among those recommended by the manufacturer, the diameter of which corresponds to the theoretical diameter according to Table 7a, after the insulation has been removed and the end has been reshaped. The stripped end of the conductor shall be able to enter completely within the clamping unit aperture, without use of undue force. Per IEC60947-7-2 section 8.3.3.5</p>

3.6.4 Environmental

Test Description	Requirement	Procedure
Needle flame test	<p>Duration of burning denotes the time interval from the moment the flame is removed until flames or glowing of the terminal block have extinguished.</p> <p>The terminal blocks are considered to have passed the test if the duration of burning is <30 s in case of ignition.</p> <p>Moreover, the tissue paper on the pinewood board shall not ignite if burning or glowing particles fall from the terminal block.</p>	<p>The test is carried out according to IEC 60695-11-5 successively in the area of one clamping unit of three terminal blocks.</p> <p>The test room shall be substantially draught-free with dimensions sufficient to ensure an adequate supply of air.</p> <p>Before the test, the terminal blocks are stored for 24 h in an atmosphere having a temperature between 15 °C and 35 °C and a relative humidity between 45 % and 75 %.</p> <p>After this preconditioning, the terminal block is mounted on its appropriate support and fixed with suitable means so that one lateral insulation wall lies parallel to the layer placed below it (see Figure 8).</p> <p>Conductors are not connected.</p> <p>The layer placed below, which consists of an approximately 10 mm thick pinewood board covered with a single layer of tissue paper (grammage between 12 g/m² to 30 g/m² according to 4.215 of ISO 4046-4:2002, is positioned at a distance of (200 ± 5) mm below the terminal block. The test flame, adjusted in accordance with Figure 1a) of IEC 60695-11-5, is guided under an angle of 45° to the lateral insulation wall.</p> <p>The tip of the flame shall make contact with the insulation wall in the area of the clamping unit (see Figure 9).</p> <p>The flame is applied for 10 s. For insulation walls <1 mm and/or an area <100 mm², the flame is applied for 5 s.</p> <p>After the flame is removed, the duration of burning in the case of ignition is measured.</p> <p>Per IEC60947-7-1 section 8.5</p>

NOTE

1. The rated cross-section is below 10 mm² (AWG 8), the conductors shall be solid. For rated cross-sections equal to or higher than 10 mm² (AWG 8), the conductors shall be rigid stranded.
2. *Shall meet visual requirements, show no physical damage, and meet requirements of additional tests as specified in the Product Qualification and Requalification Test Sequence shown in 3.6.5.*
3. *All the wire should be connected with the specified torque. Detail torque specification should refer to [table 10](#).*

3.6.5 Product Qualification and Requalification Test Sequence

Test group	A	B	C	D	E	F	G	H
Examination of product	1,3	1,5	1,5	1,4,5	1,3	1,4	1,4	1
Impulse Withstanding Voltage test	2							
Voltage drop		2,4	2,4	2,4				
Short-time withstand current test		3						
Temperature Rise				3				
Attachment of the terminal block on its support					2			
Mechanical strength of clamping units			3					
Damage to and accidental loosening of conductors of a terminal block- flexion test						2		
Pull out test						3		
Rated cross-section and rated connecting capacity							2	
Verification of rated cross-section (special test with gauges)							3	
Needle flame test								2
Sample size	5	3	5	10	5	3	2	1

4.0 Quality Assurance Provisions

4.1 Qualification Testing

A. Specimen Selection

Specimens shall be prepared in accordance with applicable Instruction Sheets and shall be selected at random from current production.

B. Test Sequence

Qualification inspection shall be verified by testing specimens as specified.

4.2. Requalification Testing

If changes significantly affecting form, fit or function are made to the product or manufacturing process, product assurance shall coordinate requalification testing, consisting of all or part of the original testing sequence as determined by development/product, quality and reliability engineering.

4.3. Acceptance

Acceptance is based on verification that the product meets the requirements. Failures attributed to equipment, test setup or operator deficiencies shall not disqualify the product. If product failure occurs, corrective action shall be taken and specimens resubmitted for qualification. Testing to confirm corrective action is required before resubmitted.

4.4. Quality Conformance Inspection

The applicable quality inspection plan shall specify the sampling acceptable quality level to be used. Dimensional and functional requirements shall be in accordance with the applicable product drawing and this specification.

5. Figures and tables for product test

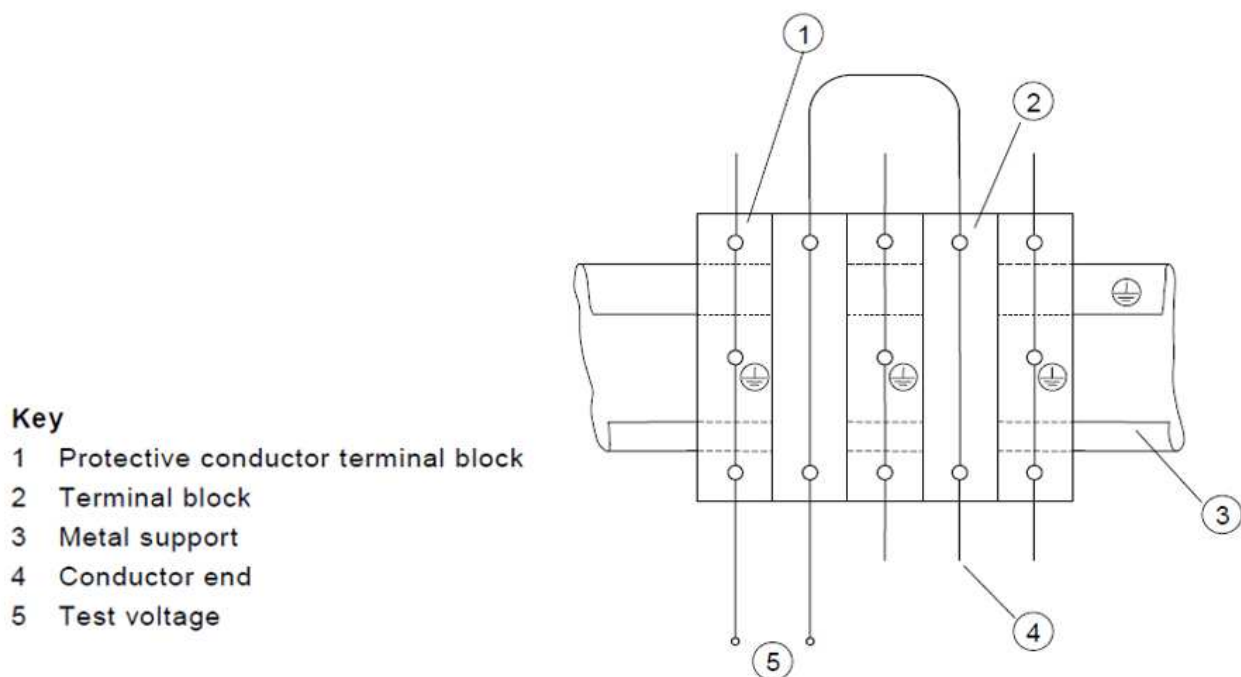
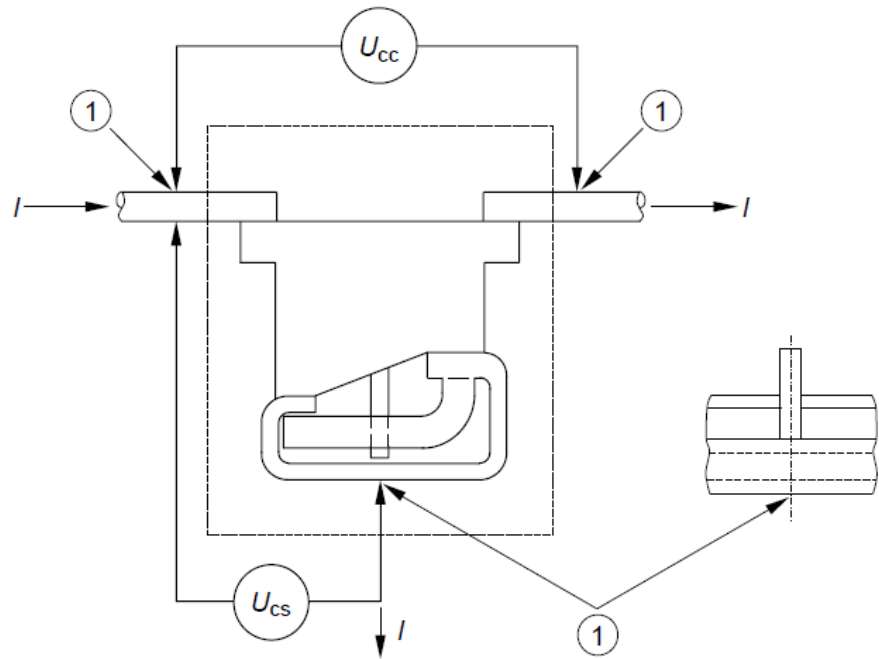

Figure 1 – Arrangement for the dielectric test (comply with IEC60947-7-2)



Key

1 Measurement point

Figure 2--Arrangement for Voltage Drop Test (comply with IEC60947-7-2)

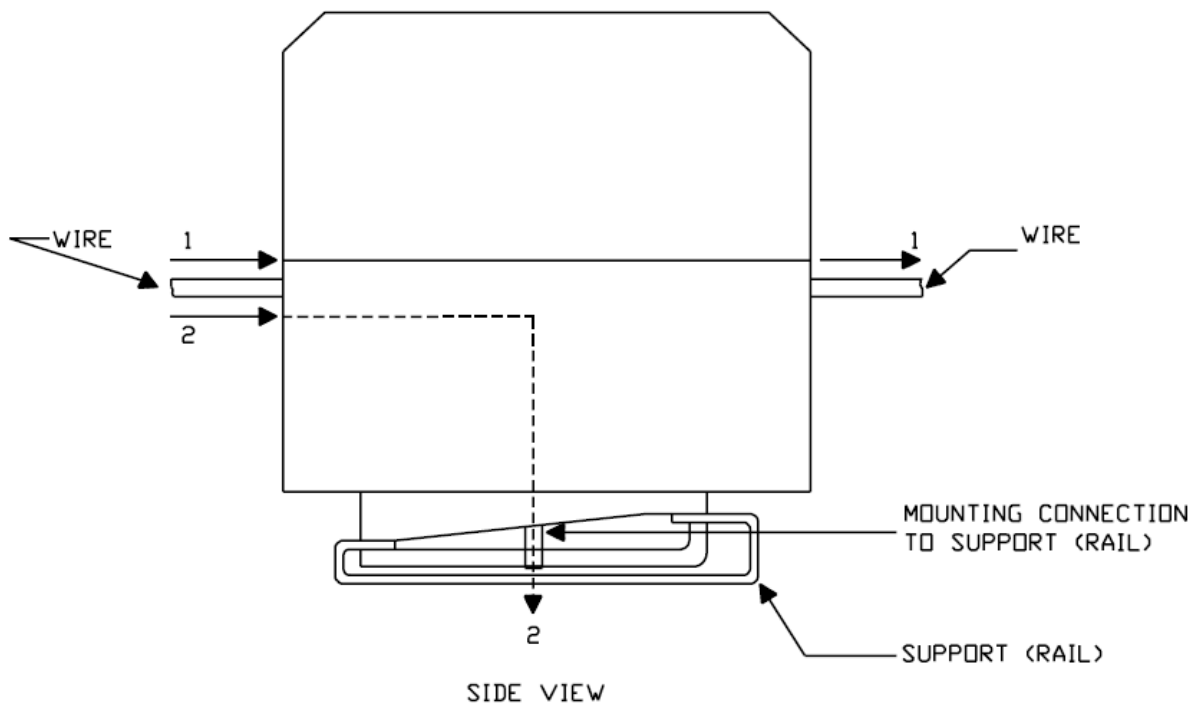

Figure 3--Current Path for Current Test

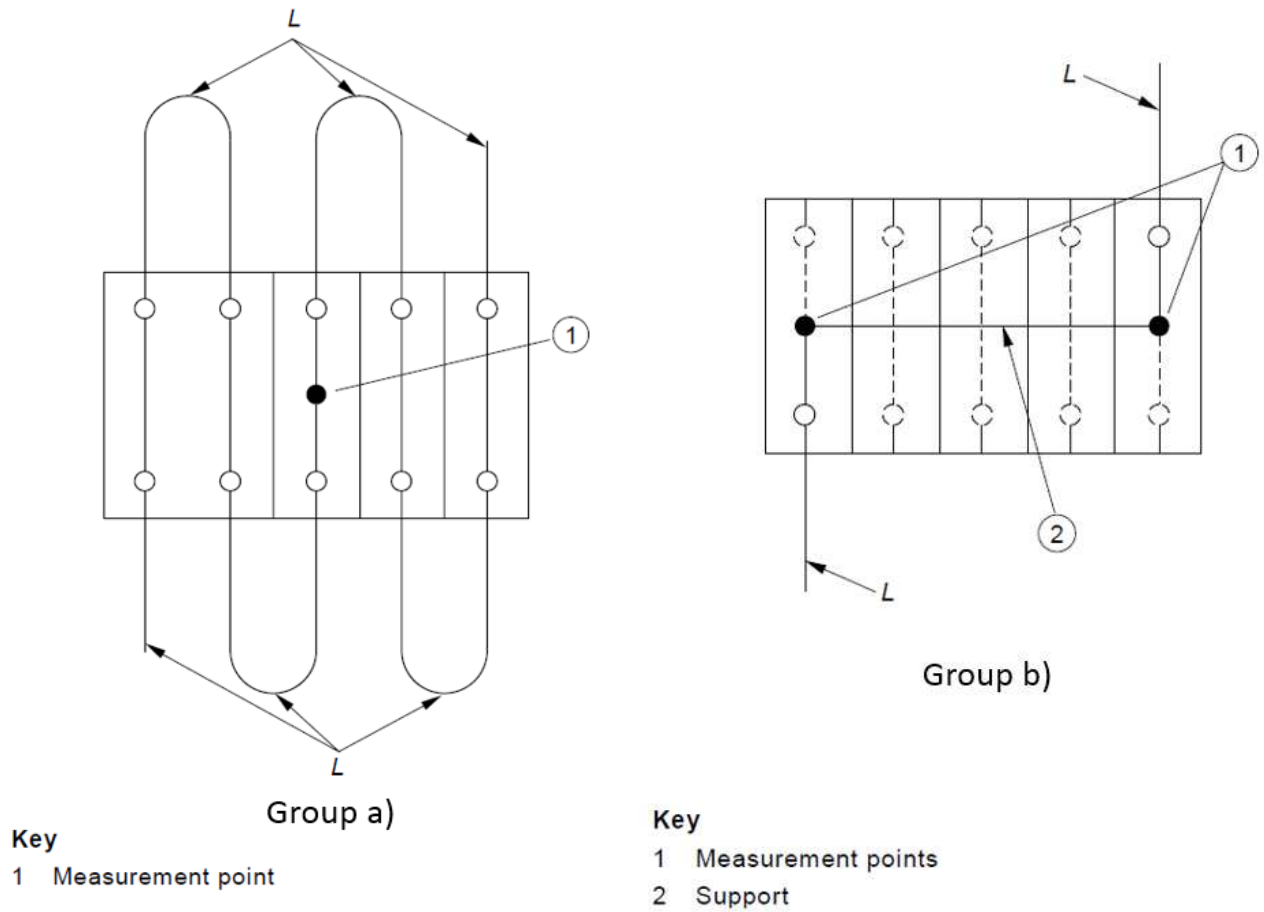

Figure 5-- Arrangement for temperature-rise test for test group a) and group b)

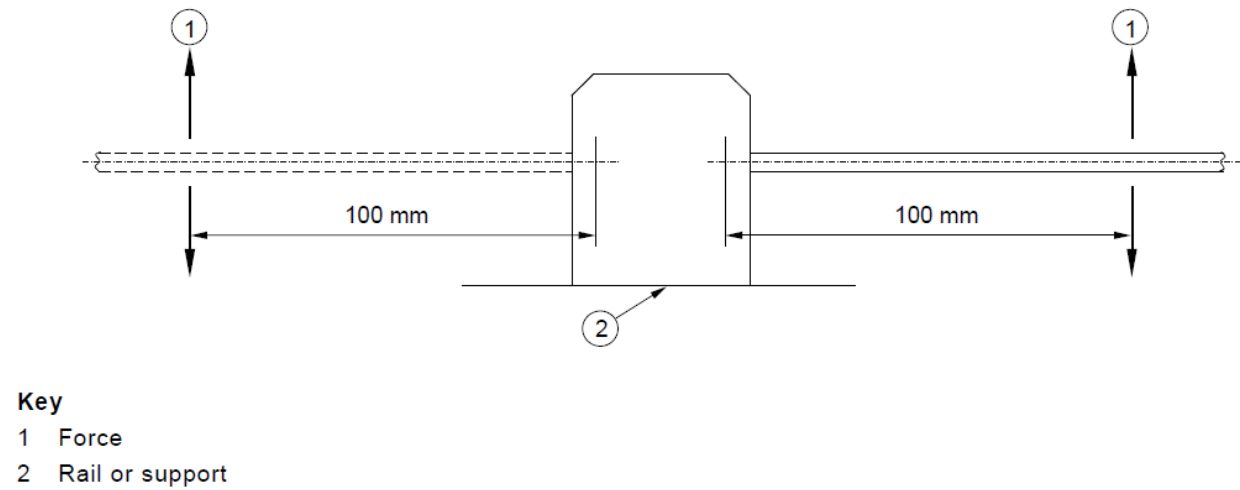

Figure 6-- Arrangement for test of Attachment of the terminal block on its support

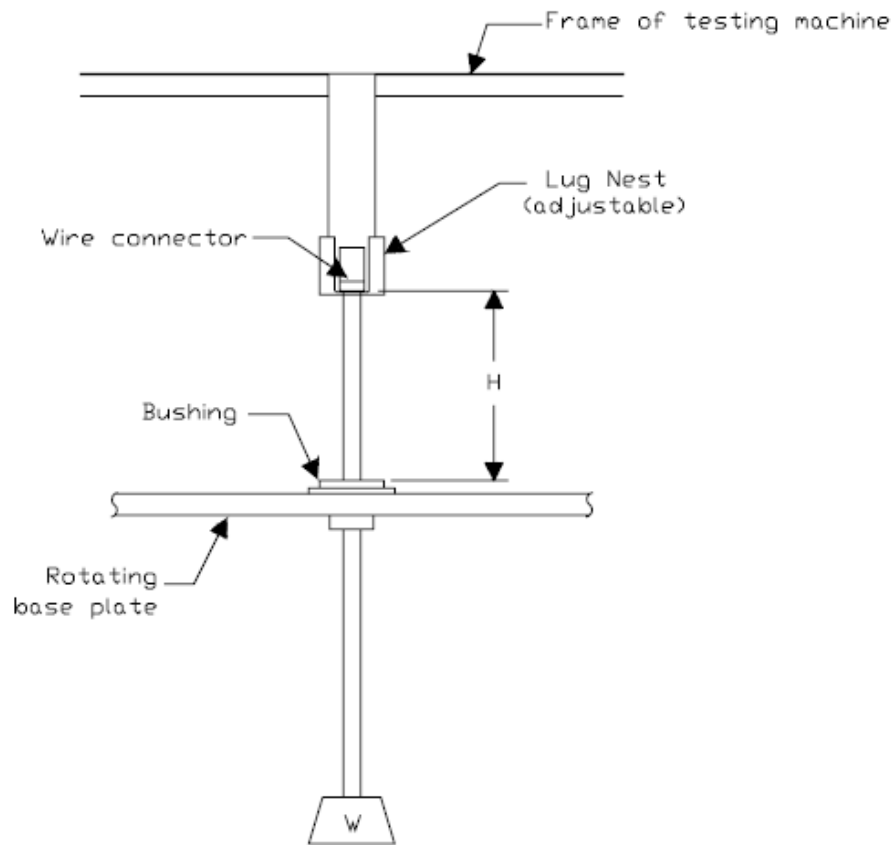
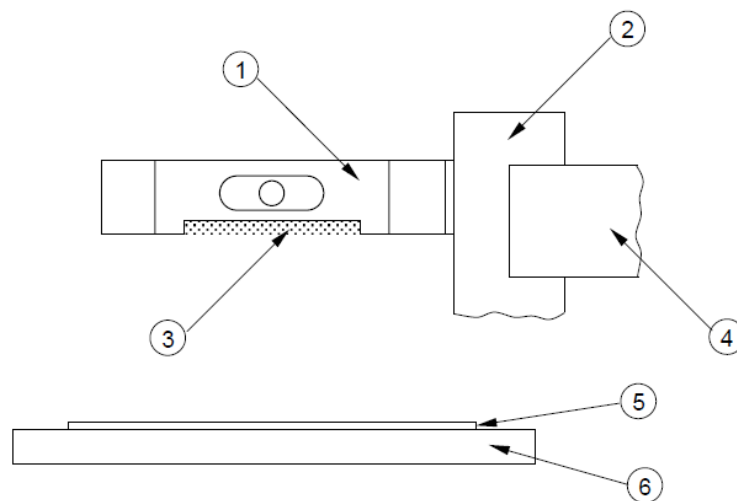

Figure 7 –Test equipment for flexion test (Secureness test)



Key

- 1 Terminal block
- 2 Support of the terminal block
- 3 Lateral insulation wall
- 4 Fixing means
- 5 Tissue paper
- 6 Pinwood board

Figure 8 –Arrangement for Needle test(comply with IEC60947-7-1)

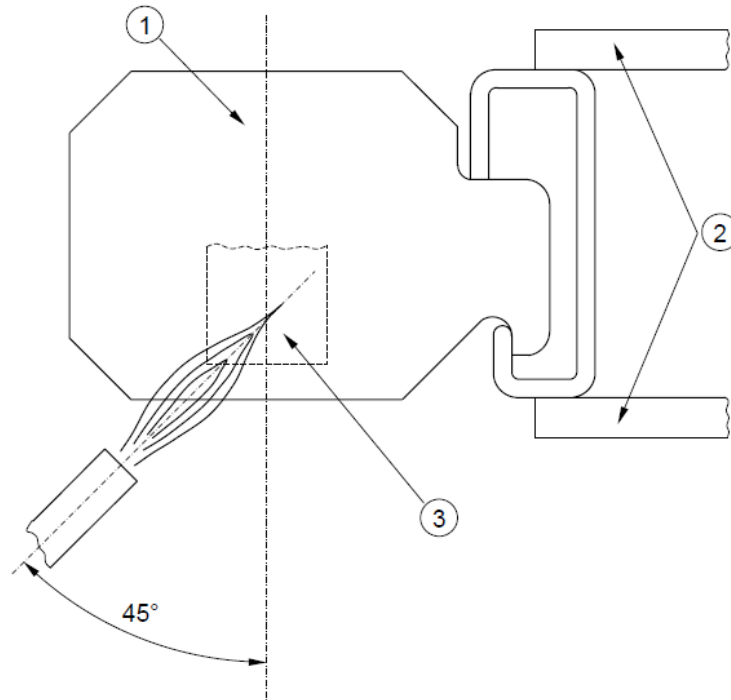

Key

- 1 Terminal block
- 2 Fixing means
- 3 Clamping part in the area of the damping unit

**Figure 9 –Point of test flame contact
 (view from the layer placed below the terminal block)**

Rated cross-section of the terminal block		Force N	Diameter of pin mm
mm ²	AWG/kcmil		
0,2	24	1	1,0
0,34	22		
0,5	20		
0,75	18		
1,0	–		
1,5	16		
2,5	14		
4	12	5	2,8
6	10		
10	8		
16	6	10	5,7
25	4		
35	2		
50	0		
70	00		

Table 1 Parameters for test of attachment of the terminal block on its support

Conductor cross-section		Diameter of bushing hole ^{a, b} mm	Height H ^a mm	Mass kg	Pulling force N
mm ²	AWG/kcmil				
0,2	24	6,5	260	0,2	10
0,34	22	6,5	260	0,2	15
0,5	20	6,5	260	0,3	20
0,75	18	6,5	260	0,4	30
1,0	–	6,5	260	0,4	35
1,5	16	6,5	260	0,4	40
2,5	14	9,5	280	0,7	50
4,0	12	9,5	280	0,9	60
6,0	10	9,5	280	1,4	80
10	8	9,5	280	2,0	90
16	6	13,0	300	2,9	100
25	4	13,0	300	4,5	135
–	3	14,5	320	5,9	156
35	2	14,5	320	6,8	190

Table 2 Parameters for secureness test and pullout force test (comply with IEC60947-7-2)

Metric standard values	Diameter of thread mm		Tightening torque N·m		
	Range of diameter		I	II	III
1,6	≤1,6		0,05	0,1	0,1
2,0	>1,6	up to and including 2,0	0,1	0,2	0,2
2,5	>2,0	up to and including 2,8	0,2	0,4	0,4
3,0	>2,8	up to and including 3,0	0,25	0,5	0,5
–	>3,0	up to and including 3,2	0,3	0,6	0,6
3,5	>3,2	up to and including 3,6	0,4	0,8	0,8
4,0	>3,6	up to and including 4,1	0,7	1,2	1,2
4,5	>4,1	up to and including 4,7	0,8	1,8	1,8
5	>4,7	up to and including 5,3	0,8	2,0	2,0
6	>5,3	up to and including 6,0	1,2	2,5	3,0
8	>6,0	up to and including 8,0	2,5	3,5	6,0
10	>8,0	up to and including 10,0	–	4,0	10,0
12	>10	up to and including 12	–	–	14,0
14	>12	up to and including 15	–	–	19,0
16	>15	up to and including 20	–	–	25,0
20	>20	up to and including 24	–	–	36,0
24	>24		–	–	50,0

Column I Applies to screws without heads which, when tightened, do not protrude from the hole, and to other screws which cannot be tightened by means of a screwdriver with a blade wider than the root diameter of the screw.

Column II Applies to nuts and screws which are tightened by means of a screwdriver.

Column III Applies to nuts and screws which can be tightened by means other than a screwdriver.

Table 4 of IEC60947-1 Parameters for Tightening torques for the verification of the mechanical strength of screw-type terminals

Rated cross-section mm ²	0,2	0,34	0,5	0,75	1	1,5	2,5	4	6	10	16
Test current A	4	5	6	9	13,5	17,5	24	32	41	57	76

Rated cross-section mm ²	25	35	50	70	95	120	150	185	240	300
Test current A	101	125	150	192	232	269	309	353	415	520

**Table 4 of IEC60947-7-1 Values of test current for temperature-rise test, ageing test
and voltage drop verification for metric wire sizes**

Rated cross-section AWG	24	22	20	18	16	14	12	10	8	6	4
Test current A	4	6	8	10	16	22	29	38	50	67	90

Rated cross-section AWG or kcmil	2	1	0	00	000	0000	250 kcmil	300 kcmil	350 kcmil	500 kcmil	600 kcmil
Test current A	121	139	162	185	217	242	271	309	353	415	520

**Table 5 of IEC60947-7-1 Values of test current for temperature-rise test, ageing test
and voltage drop verification for AWG or kcmil wire sizes**

Conductor cross-section		Gauge (see Figure 2)						Permissible deviation for a and b
Flexible conductors	Rigid conductors (solid or stranded)	Form A			Form B			
		Marking	Diameter a mm	Width b mm	Marking	Diameter a mm		
mm ²	mm ²						mm	
1,5	1,5	A1	2,4	1,5	B1	1,9	0 -0,05	
2,5	2,5	A2	2,8	2,0	B2	2,4		
2,5	4	A3	2,8	2,4	B3	2,7		
4	6	A4	3,6	3,1	B4	3,5	0 -0,06	
6	10	A5	4,3	4,0	B5	4,4		
10	16	A6	5,4	5,1	B6	5,3		
16	25	A7	7,1	6,3	B7	6,9	0 -0,07	
25	35	A8	8,3	7,8	B8	8,2		
35	50	A9	10,2	9,2	B9	10,0		

**Table 7 Maximum conductor cross-sections and corresponding gauges
(Comply with IEC60947-7-1)**

Conductor cross-section	Theoretical diameter of the largest conductor						
	Metric			AWG/kcmil			
	Rigid		Flexible	Gauge	Rigid		Flexible
Solid	Stranded		b		b Class B	c Classes I.K.M.	
mm ²	mm	mm	mm		mm	mm	mm
0,2	0,51	0,53	0,61	24	0,54	0,61	0,64
0,34	0,63	0,66	0,8	22	0,68	0,71	0,80
0,5	0,9	1,1	1,1	20	0,85	0,97	1,02
0,75	1,0	1,2	1,3	18	1,07	1,23	1,28
1,0	1,2	1,4	1,5	–	–	–	–
1,5	1,5	1,7	1,8	16	1,35	1,55	1,60
2,5	1,9	2,2	2,3 ^a	14	1,71	1,95	2,08
4,0	2,4	2,7	2,9 ^a	12	2,15	2,45	2,70
6,0	2,9	3,3	3,9 ^a	10	2,72	3,09	3,36
10,0	3,7	4,2	5,1	8	3,43	3,89	4,32
16,0	4,6	5,3	6,3	6	4,32	4,91	5,73
25,0	–	6,6	7,8	4	5,45	6,18	7,26
35,0	–	7,9	9,2	2	6,87	7,78	9,02

Table 7a Relationship between conductor cross-section and diameter
(Comply with IEC60947-7-1)

Rail profile	Material	Equivalent E-Cu cross-section mm ²	Short-time withstand current 1 s kA	Thermal rated current of a PEN busbar A
"Top hat" rail IEC 60715/TH 15-5,5	Steel	10	1,2	–
	Copper ^a	25	3	101
	Aluminium ^a	16	1,92	76
G-type rail IEC 60715/G32	Steel	35	4,2	–
	Copper ^a	120	14,4	269
	Aluminium ^a	70	8,4	192
"Top hat" rail IEC 60715/TH 35-7,5	Steel	16	1,92	–
	Copper ^a	50	6	150
	Aluminium ^a	35	4,2	125
"Top hat" rail IEC 60715/TH 35-15	Steel	50	6	–
	Copper ^a	150	18	309
	Aluminium ^a	95	11,4	232

^a Copper or aluminium alloys selected by the manufacturer of the terminal block assembly to achieve the values in the table.

Table A.1 Maximum short-time withstand currents allocated to the rail profile
and thermal rated current of a PEN busbar (Comply with IEC60947-7-2)

Rated impulse withstand voltage U_{imp} kV	Test voltages and corresponding altitudes				
	$U_{1,2/50}$ kV				
	Sea level	200 m	500 m	1 000 m	2 000 m
0,33	0,35	0,35	0,35	0,34	0,33
0,5	0,55	0,54	0,53	0,52	0,5
0,8	0,91	0,9	0,9	0,85	0,8
1,5	1,75	1,7	1,7	1,6	1,5
2,5	2,95	2,8	2,8	2,7	2,5
4,0	4,8	4,8	4,7	4,4	4,0
6,0	7,3	7,2	7,0	6,7	6,0
8,0	9,8	9,6	9,3	9,0	8,0
12	14,8	14,5	14	13,3	12

NOTE Table 12 uses the characteristics of a homogeneous field, case B (see 2.5.62).

Table 12 of IEC60947-1 Impulse withstand test voltages

TE型号	Part Number	IEC			UL			Rated Impulse Voltage (KV)	Terminal screw		Mounting screw		Wire Strip Length
		Rated Voltage (V)	Rated Current (A)	Wire Range (mm²)	Rated Voltage (V)	Rated Current (A)	Wire Range (AWG)		Screw Size	Torque Spec. (in-lbs/Nm)	Screw Size	Torque Spec. (in-lbs/Nm)	
DTC 2.5-G	2271687.*	/	/	0.08-2.5	600	/	28-12	8	M2.6	4-5.2 / 0.46-0.6	M2.6	3.5-4.4 / 0.4-0.5	8-10
DTC 4-G	2271688.*	/	/	0.14-4	600	/	26-10	8	M3	5-6.2 / 0.56 -0.7	M3	4.4-5.6 / 0.5-0.64	8-10
DTC 6-G	2271689.*	/	/	0.14-6	600	/	26-8	8	M3.5	10-14 / 1.15-1.6	M4	9-12 / 1.03-1.38	10-12
DTC 10-G	2271690.*	/	/	0.2-10	600	/	24-6	8	M4	13-16 / 1.5-1.8	M4	9-12 / 1.03-1.38	10-12
DTC 16-G	2271691.*	/	/	2.5-16	/	/	14-6	8	M5	35 / 4.02	M4	4.5-5.6 / 0.5-0.6	14-18
DTC 35-G	2271692.*	/	/	6-35	/	/	10-2	8	M6	51 / 2.5-5.86	M3	4.5-5.6 / 0.52-0.65	14-18

Table 10 Parameter for Protective conductor Terminal Block