

HVP-HD1400 PRODUCT SPECIFICATION
HVP-HD1400 高压连接器 产品规范

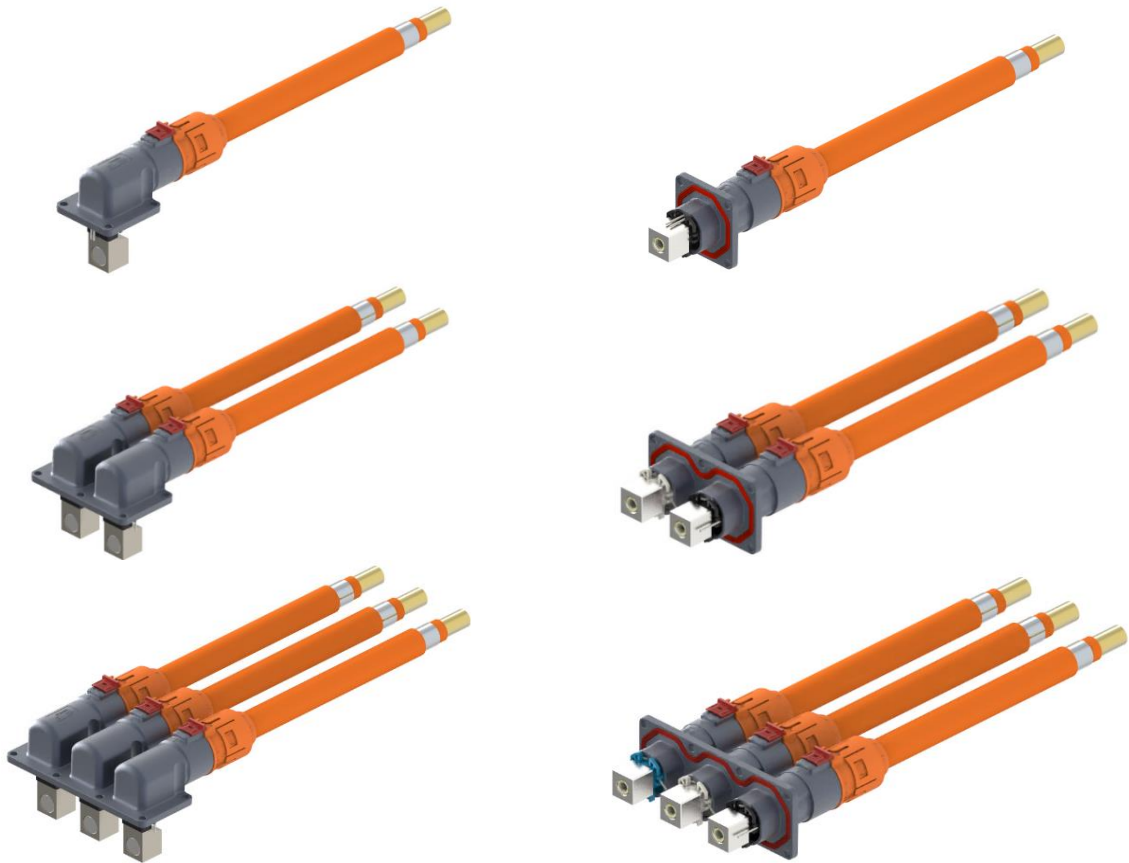

				PR: S.TAN DATE:20JUL2024	 TE Connectivity Shanghai, China		
				CHK: J.LI DATE:20JUL2024			
A	Release	S. T	20JUL2024	APP: Z.ZHOU DATE:20JUL2024		Document No.: 108-160407	LOC: ES
LTR	REVISION RECORD	PR	DATE				

CONTENT 目录

1. SCOPE 适用范围.....	3
1.1 CONTENT 内容.....	3
1.2 QUALIFICATION 鉴定	3
2. APPLICABLE DOCUMENTS 适用文件.....	3
2.1 USABLE DOCUMENT 使用文件.....	3
2.2 TE SPECIFICATIONS 泰科电子规范	3
2.3 CUSTOMER DRAWINGS 客户图纸.....	3
2.4 SPECIFICATIONS 规范.....	4
2.5 OTHER SPECIFICATIONS 其他规范	5
3. REQUIREMENT 要求.....	5
3.1 DESIGN AND CONSTRUCTION 设计和结构	5
3.2 MATERIAL 材料	5
3.3 TEST PARAMETERS AND TOLERANCES 测试参数与公差	5
3.4 PRODUCT RATINGS 等级.....	6
3.5 GENERAL PERFORMANCE AND TEST DESCRIPTION 通用性能和试验描述	6
3.6 TESTS REQUIREMENT AND PROCEDURES SUMMARY 测试要求及方法.....	6
3.7 ADDITIONAL TEST PROCEDURES AND TEST RESULTS 附加的测试方法和结果	12
4. QUALITY 质量.....	12
4.1 QUALIFICATION TEST 鉴定	12
4.2 REQUALIFICATION TEST 重新鉴定	12
4.3 ACCEPTANCE 验收.....	13
4.4 QUALITY CONFORMANCE INSPECTION 质量合格检验.....	13
5. APPENDIX 附件	13
5.1 DERATING INSIDE HOUSING 成品温升降额曲线.....	13
5.2 DYNAMIC LOAD (ISO16750-3) 振动性能 (ISO16750-3).....	24
5.3 CONTACT ENGAGEMENT LENGTH 端子接触长度	24
5.4 STRAIN RELIEF 应力释放.....	25

1. SCOPE 适用范围

1.1 Content 内容

TE Connectivity' HVP-HD1400 is designed to meet LV215 specifications (vibration refers to ISO16750-3 while salt spray refers to VDA233-102), there are 70 mm²、95 mm²、120 mm²、150mm² four kinds of metric wire size (acc. to ISO 6722-1 class D, ISO 19642-9 class D).

With a 180° cable outlet incorporates the connector system 14mm Power contacts and an integrated High Voltage Interlock (HVIL) System. The HVP-HD1400 header can be divided into two parts: 90Deg and 180Deg. All of them have 1POS、2POS、3POS, equipped with 12 different keying or polarizing configurations. It incorporates 360° conductive EMI shields to reduce radiated emissions in the application. The housings are molded in orange to denote a high voltage system.

泰科电子的 HVP-HD1400 设计符合 LV215 标准(振动符合 ISO16750-3,盐雾符合 VDA233-102), 有 70 mm²、95 mm²、120 mm² 以及 150mm² 四种公制线径 (符合 ISO 6722-1 class D, ISO 19642-9 class D)。

密封连接系统采用 180°出线, 14mm 电源连接和一个高压互锁系统。HVP-HD1400 连接器公端分为 90°以及 180°两大类, 有 1POS、2POS、3POS 三种, 拥有 12 种键位, 并采用 360 度导电 EMI 屏蔽以减少应用中的辐射。外壳体采用橙色警示色代表高压系统。

This specification covers the performance, test and quality requirements for TE Connectivity HVP-HD1400.

本规范适用于泰科电子 HVP-HD1400 的性能, 测试和质量要求。

1.2 Qualification 鉴定

When tests are performed, the following specifications and standards shall be used. All inspections shall be performed using the applicable inspection plan and product drawing.

本测试规范依照下面的规范及标准执行。所有的检验应依照合适的检验计划及产品图纸执行。

2. APPLICABLE DOCUMENTS 适用文件

2.1 Usable document 使用文件

In the event of conflict between the requirements of this specification and the drawing, the product drawing shall take precedent.

In the event of conflict between the requirement of this specification and the referenced documents, this specification shall take precedent.

在本规范的要求与图纸发生冲突时, 以产品图纸为准。在本规范的要求与参考文件发生冲突时, 以本规范为准。

2.2 TE specifications 泰科电子规范

TEC-109-1: General requirements for Test Specifications / 测试通用规范

2.3 Customer drawings 客户图纸

Table 1: Customer drawings / 客户图纸

Header side (Include interface) / 公端(包括应用面板)	
2399606	HVP-HD1400 1POS HEADER ASSY,180DEG
2399607	HVP-HD1400 2POS HEADER ASSY,180DEG
2399608	HVP-HD1400 3POS HEADER ASSY,180DEG

2399609	HVP-HD1400 1POS HEADER ASSY,90DEG
2399610	HVP-HD1400 2POS HEADER ASSY,90DEG
2399611	HVP-HD1400 3POS HEADER ASSY,90DEG

Variant part numbers for header, please refer to this specification.
The specific variant part number can be obtained through the local TE representative or by calling the product information center.

变种料号可参照该规范。

具体变种料号可通过当地 TE 代表获得，或者拨打产品信息中心电话。

Plug side / 母端	
2399663	HVP-HD1400 PLUG PRE-ASSEMBLY
2446256	HVP-HD1400 PLUG PRE-ASSEMBLY WITHOUT TPA
2399679	PLUG TPA
2386340	CONTACT ASSY
2399666	SPACER
2387548	SHIELD SLEEVE
2387549	CRIMP ANVIL
2399667	SINGLE WIRE SEAL (SWS)
2399668	CABLE CLIP
2399669	CABLE COVER

2.4 Specifications 规范

Table 2: TE-specifications / 泰科规范

Specifications	Description
108-18030	Product Specification MQS contact system
108-160407	Product Specification HVP-HD1400 connector
114-94737	General Guideline for the application of EMPT connections
114-18021	Application Specification MQS contact system
114-160222	Application Specification HVP-HD1400 header

114-160223	Application Specification HVP-HD1400 plug – standard cable
114-160418	Application Specification HVP-HD1400 plug – high flex cable

2.5 Other Specifications 其他规范

Table 3: Other Specifications / 其他规范

Doc number	Edition	Standard: Title, Author
DIN 40050-9	1993-05	Degrees of protection (IP-Code) - Protection of electrical equipment against foreign objects, water, and access
ISO 20653	2006-08	Road vehicles – Degrees of protection (IP Code) - Protection of electrical equipment against foreign objects, water, and access
ISO 16750-3	2012-12	Road vehicles — Environmental conditions and testing for electrical and electronic equipment — Mechanical loads
SAE J 1742	2005-12	Connections for High Voltage On-Board Road Vehicle, Electrical Wiring Harnesses Test Methods and General Performance Requirements
LV 214	2010-03	Test specification for motor vehicle connectors
LV 215	2013-03	Electrical/Electronic Requirements of HV Connectors
LV 215	2016-11	Electrical/Electronic Requirements of HV Connectors
VDA233-102	2013-06	Cyclic corrosion test of materials and component in automotive construction
USCAR-2-6	2013-02	Performance Specification for Automotive Electrical Connector Systems
DIN EN 60664-1	2008-01	Isolation coordination for equipment within low-voltage systems – Part 1: Principles, requirements, and tests

3. REQUIREMENT 要求

3.1 Design and construction 设计和结构

Products must meet the design, construction and physical dimensions specified in the applicable product drawings.

产品必须满足产品图纸上的设计，结构和尺寸要求。

3.2 Material 材料

Description of the material is found in the related customer drawings.

材料描述见相关客户图纸。

3.3 Test parameters and tolerances 测试参数与公差

Table 4: Test parameters and tolerances / 测试参数与公差

Requirement 要求	Tolerance 公差
Ambient temperature 环境温度	23°C ± 5°C
Relative humidity 相对湿度	45% to 75%
Atmospheric pressure 大气压力	100kPa ± 10kPa

3.4 Product ratings 等级

Table 5: Product ratings / 产品等级

Description	Range
Max. Voltage according to DIN EN 60664-1	1000VDC
Voltage class acc. ISO 6469-3	B
Dielectrics withstand voltage	4000VDC
Insulation resistance acc. ISO 6469-3, SAE J 1742	> 200MΩ
Isolation Group I acc. DIN EN 60664-1	CTI ≥ 600
Pollution degree acc. DIN EN 60664-1	2
Ambient temperature	-40°C to 140°C
Degrees of protection (IP-Code) against access acc. ISO 20653	IPXXB
Degrees of protection (IP-Code) against foreign objects and water acc. ISO 20653	IP6K9K IPX8: 1M depth, 48H
Color of plastic housing	Orange (RAL 2003)
Flammability of plastic housing	UL94-V0
Durability mating cycle	50

3.5 General Performance and Test description 通用性能和试验描述

The product is designed to meet the electrical, mechanical, and environmental performance requirements specified in table 6 and table 7. All testes must be performed at the test condition of the TE test specification TEC-109-1 unless otherwise specified.

产品应能满足表 6 和表 7 中的电气，机械和环境等性能要求。所有试验均需按照 TE 规范 TEC-109-1 中的测试条件进行，除非另有说明。

3.6 Tests requirement and procedures summary 测试要求及方法

Not shown test-details see LV215 / Nov. 2016, LV215 / March 2013, LV214 / March 2010.
更多细节请查询 LV215/2016.11, LV215/2013.03, LV214/2010.03。

Table 6: Test Requirements and Procedures Summary / 测试要求及方法

Test Description	Requirement	Procedure
PG 0 INSPECTION OF AS-RECEIVED CONDITION		
E 0.1 Visual inspection	No Defect	LV215-2
E 0.2 Contact resistance	<ul style="list-style-type: none"> • Contact $\leq 0.12\text{m}\Omega$ (70mm²) • Contact $\leq 0.11\text{m}\Omega$ (95mm²) • Contact $\leq 0.10\text{m}\Omega$ (120mm²/150mm²) • HVIL-contact Single terminal < 15mΩ • Shielding contact < 9mΩ 	LV215-2
E 0.3 Insulation resistance	<ul style="list-style-type: none"> • Every HV potential to each other • Every HV potential to shielding • Every HV potential to HVIL R > 200 MΩ at V = 1000 V DC, t = 60 s • Shielding to HVIL R > 100 MΩ at V = 500 V DC, t = 60 s 	LV215-2
E 0.4 Dielectric strength	<ul style="list-style-type: none"> • Every HV potential to each other • Every HV potential to shielding • Every HV potential to HVIL Leakage current < 10mA at V= 4000V DC, t=60s 	LV215-2
PG 6 INTERACTION BETWEEN CONTACT AND CONTACT HOUSING		
E 6.1 Deflection of contacts	Theoretical documentation	LV215-2
E 6.2 The primary lock/latch play	The primary lock must latch audibly and must be checked by pulling it back.	LV215-2
E 6.3 The TPA/PLR lock/latch play	The TPA/PLR lock must be closable at the end stop. The TPA/PLR lock must not be closable until all contacts are properly locked in the housing cavity in the correct position.	LV215-2
B 6.1 Drop test	Drop test from 1m height; No damage or impairments of function	LV215-2
E 6.4 Actuation force	TPA Open: 10-50N TPA Close: <50N	LV215-2
PG 7 HANDING AND FUNCTIONAL RELIABILITY OF THE HOUSING		
E 7.1 Error-proof design of housings	Coding/Polarization test load: 80N	LV215-2
E 7.2 Retention force of the housing latch/lock	Retention force of the housing latch mechanism/housing interlock: > 250N	LV215-2
E 7.3 CPA function check	CPA actuation force activating: 5 - 30 N CPA actuation force opening: 5 – 30N CPA Efficiency: > 80 N	LV215-2

E 7.4 Insertion force or actuation force for insertion and extraction aids	Insertion and actuation force: $\leq 100\text{N}$	LV215-2
E 7.5 IP protection test	The IP protection class shall be determined after load force 250N	LV215-2
PG 8 MATING AND RETENTION FORCE OF CONTACT PARTS		
E 8.1 Contact insertion forces	Document data	LV215-2
E 8.2 Contact insertion and pull-out strength in the contact housing	HV female terminal $> 150\text{N}$ HV male terminal $> 150\text{N}$ HVIL terminal $> 30\text{N}$	LV215-2
PG10 CONTACT: SHIELD PULL OUT STRENGTH		
E 10.1 Tear-off force	<ul style="list-style-type: none"> • Contact tear-off force $\geq 3400\text{N}$ (70mm^2) • Contact tear-off force $\geq 4200\text{N}$ (95mm^2) • Contact tear-off force $\geq 4800\text{N}$ ($120\text{mm}^2/150\text{mm}^2$) • Shield tear-off force $> 450\text{N}$ 	LV215-2
PG 11 INSERTION AND WITHDRAWAL FORCE; INSERTION FREQUENCY		
B 11.1 Mating cycle frequency	Number: 50	LV215-2
PG 13 HOUSING INFLUENCE ON THE DERATING		
E 13.2 Derating with housing	Dependent on application and cable type different values are possible Max. temperature at contact 150°C Derating see appendix 5.1	LV215-2
PG14 THERMAL TIME CONSTANT CONNECTOR		
E 14.1 Thermal time constant	Loading of a contact with 1/2/3/4/5 times the nominal current Simultaneous recording of the temperature curve over time until stabilization occurs or until the max. permissible component temperature 150°C is reached.	LV215-2
DYNAMIC LOADING		
Test Level IX	Monitor interruption: $> 7\Omega > 1\mu\text{s}$, record data Contact resistance after testing <ul style="list-style-type: none"> • Contact $\leq 0.20\text{m}\Omega$ ($120\text{mm}^2/150\text{mm}^2$) • HVIL-contact Single terminal $< 15\text{m}\Omega$ • Shielding contact $< 9\text{m}\Omega$ Details see appendix 5.2	ISO 16750 - 3

In the event of particularly critical installation conditions, special agreements shall be made between the manufacturer and the user.

SALT SPRAY LOAD

Salt spray, cyclic	Duration time: 8 weeks, 7days each week. Contact resistance after testing <ul style="list-style-type: none"> • Contact $\leq 0.20\text{m}\Omega$ (120mm²/150mm²) • HVIL-contact Single terminal < 15mΩ • Shielding contact <9mΩ 	VDA233-102
B23.1 Immersion with vacuum	Each pressure states -10 kPa, holding time 5 min -50 kPa, holding time 5 min	LV215-2
E 0.3 Insulation resistance	Insulation resistance after testing <ul style="list-style-type: none"> • Every HV potential to each other • Every HV potential to shielding • Every HV potential to HVIL R > 200 M Ω at V = 1000 V DC, t = 60 s <ul style="list-style-type: none"> • Shielding to HVIL R > 100 M Ω at V = 500 V DC, t = 60 s	LV215-2

In the event of particularly critical installation conditions, special agreements shall be made between the manufacturer and the user.

PG19
ENVIRONMENTAL SIMULATION

B 19.1 Temperature shock	Duration: 144 cycles Temperature: -40°C /140°C per 15min	LV215-2
B 19.2 Temperature cycle	Duration: 20 cycles Temperature: -40°C /140°C per 3h	LV215-2
B 19.3 Aging in dry heat	Duration: 120h Temperature: 140°C	LV215-2
B 19.5 Humid heat, cyclic	Relative humidity: 95% constant Duration: 10cycles of 24h each Temperatures: 25°C/ 55°C	LV215-2
E 0.3 Insulation resistance	After testing R \geq 50M Ω at V = 1000 V DC, t = 60 s	LV215-2
E 0.2 Contact resistance	After testing <ul style="list-style-type: none"> • Contact $\leq 0.20\text{m}\Omega$ (120mm²/150mm²) • HVIL-contact Single terminal < 15mΩ • Shielding contact <9mΩ 	LV215-2

PG 20
CLIMATIC LOAD OF HOUSING

B 20.1 Aging in dry heat	Duration: 120h Temperature: 140°C	LV215-2
-----------------------------	--------------------------------------	---------

B 20.2 Aging in damp heat	<ul style="list-style-type: none"> • Duration: 10days Temperature: 40°C Relative humidity: 95% • Insulation resistance after testing Every HV potential to each other Every HV potential to shielding Every HV potential to HVIL R > 200 MΩ at V = 1000 V DC, t = 60 s Shielding to HVIL R > 100 MΩ at V = 500 V DC, t = 60 s 	LV215-2
B 20.3 Aging in low temperature	Duration: 48h Temperature: - 40°C	LV215-2
B 20.4 Removal and insertion at -20 °C	Removal and insertion at -20 °C	LV215-2
B 20.5 Aging in dry heat	Duration: 48h Temperature: 80°C	LV215-2
B 6.1 Drop test after aging	Drop test from 1m height; No damages or impairments of function	LV215-2
PG 21 LONG-TERM AGING		
B 21.1 Aging in dry heat	1000h at 140°C Contact resistance after testing <ul style="list-style-type: none"> • Contact ≤ 0.20mΩ (120mm²/150mm²) • HVIL-contact Single terminal < 15mΩ • Shielding contact < 9mΩ Functionality; Contact removal forces acc. E8.2	LV215-2
PG 22B CHEMICAL RESISTANCE		
B 22.1 Resistance to chemicals	The DUTs must be exposed to the media (No Biodiesel and No battery) and aged for 48 h at the required aging temperature. Insulation resistance > 100MΩ	LV215-2
PG 23 WATER TIGHTNESS		
B 19.3 Aging in dry heat	120h at 140°C	LV215-2
B 19.1 Temperature shock	Duration: 144 cycles Temperature: - 40°C / 140°C per 15min	LV215-2
B23.1 Immersion with vacuum	Each pressure states -10 kPa, holding time 5 min -50 kPa, holding time 5 min	LV215-2
B 23.2 Immersion with pressure difference	Movement of cable for each pressure stage during the pressurization. -10 kPa, holding time 5 min -50 kPa, holding time 5 min	LV215-2

B 23.3 Thermal shock test, air-fluid	30min. in 120°C; 15min. in 0°C water 5cycles		LV215-2
B 23.4 High pressure spray	Severity: IP X9K Test duration per side: 15s Distance from DUT to nozzle: 10-15cm Pressure: 80 bar Temperature: 80°C		LV215-2
E 0.3 Insulation resistance	Insulation resistance after testing <ul style="list-style-type: none"> • Every HV potential to each other • Every HV potential to shielding • Every HV potential to HVIL • Shielding to HVIL R > 100 MΩ at V = 500 V DC, t = 60 s		LV215-2
PG 28 LATCHING NOISE			
E 28.1 Locking noise	Locking noise ≥ 70 dB(A).		LV215-2
PG49A DUST TIGHTNESS			
E 23.1 Imperviousness to dust	Test duration: 20 cycles 20 minutes each Dust test: IP6KX		ISO 20653
PG49B WATER TIGHTNESS AFTER DUST LOAD			
E 23.1 Imperviousness to dust	Test duration: 20 cycles 20 minutes each Dust test: IP6KX		ISO 20653
B 23.1 Immersion with pressure difference	Each pressure states -10 kPa, holding time 5 min -50 kPa, holding time 5 min		LV215-2
E 0.3 Insulation resistance	Insulation resistance after testing <ul style="list-style-type: none"> • Every HV potential to each other • Every HV potential to shielding • Every HV potential to HVIL • Shielding to HVIL R > 200 MΩ at V = 1000 V DC, t = 60 s R > 100 MΩ at V = 500 V DC, t = 60 s		LV215-2
PG 50 EMC – ELECTROMAGNETIC COMPATIBILITY			
E 50.2 EMC- Electromagnetic compatibility	Frequency	Delta-Transfer impedance	LV 215-1 LV 215-2
	DC	< 9mΩ	
	2MHz	< 10mΩ/m	
	30MHz	< 50mΩ/m	
PG 51 IP-PROTECTION OPEN CONNECTOR			
E 51.1 Protection open connector	IP-Protection IPXXB, un-mated (VDE test finger Ø12mm) IP-Protection IPXXD, mated		ISO 20653

3.7 Additional Test Procedures and Test Results 附加的测试方法和结果

Table 7: Additional test requirements / 附加的测试方法和结果

Test Description	Requirement	Procedure
IPX8	Aging condition 120°C, 48H 1m depth, 48H, No leakage	ISO 20653
109-18212 PG I		
1. Outside view crimp	No corrosion, discoloration, cracks	TE-Spec. 109-18212
2. Cross section	Cross section examination: crimp sleeves are well formed	TE-Spec. 109-18212
109-18212 PG II		
1. Crimp resistance	Crimp resistance before testing <ul style="list-style-type: none"> • Contact crimp $\leq 0.019\text{m}\Omega$ (70mm²) • Contact crimp $\leq 0.016\text{m}\Omega$ (95mm²) • Contact crimp $\leq 0.014\text{m}\Omega$ (120mm²/150mm²) • Shield crimp $\leq 2\text{m}\Omega$ 	TE Spec. 109-18212
2. Temperature shock	- 40 °C / 140 °C, 15 min., 500 cycles Crimp resistance after testing <ul style="list-style-type: none"> • Contact crimp $\leq 0.038\text{m}\Omega$ (70mm²) • Contact crimp $\leq 0.032\text{m}\Omega$ (95mm²) • Contact crimp $\leq 0.028\text{m}\Omega$ (120mm²/150mm²) • Shield crimp $\leq 3\text{m}\Omega$ 	TE Spec. 109-18212
3. Humid heat cycling	95% rel. humidity, 25°C /55°C, 10 cycles 24h Crimp resistance after testing <ul style="list-style-type: none"> • Contact crimp $\leq 0.038\text{m}\Omega$ (70mm²) • Contact crimp $\leq 0.032\text{m}\Omega$ (95mm²) • Contact crimp $\leq 0.028\text{m}\Omega$ (120mm²/150mm²) • Shield crimp $\leq 3\text{m}\Omega$ 	TE Spec. 109-18212
<ul style="list-style-type: none"> • Cable used for crimp validation HUBER+SUHNER STD 806104C (70mm², 95mm² and 120mm²) • Cable used for crimp validation HUBER+SUHNER STD 859519E (70mm², 95mm², 120mm² and 150mm²) 		

4. QUALITY 质量

4.1 Qualification test 鉴定

Samples must be in accordance with drawings and be taken in a random way in the production in progress.

样件必须与产品图纸一致，并且是生产过程中随机选取的。

4.2 Requalification test 重新鉴定

If changes significantly affecting form, fit, or function are made to the product or to the manufacturing process, product assurance shall coordinate requalification testing, consisting of all or part of the original testing sequence as determined by product engineering.

如果产品或者制造过程中有显著影响外观，装配和功能的设定，质保需要协调按照原先工程定义的测试顺序，重新验证全部或者部分测试项目。

4.3 Acceptance 验收

Acceptance is based on verification that the product meets the requirements of section 3.6. Failures attributed to equipment, test setup, or operator deficiencies shall not disqualify the product. When product failure occurs, corrective action shall be taken, and samples resubmitted for qualification. Testing to confirm corrective action is required before acceptance.

验收基于验证产品符合第 3.6 节的要求。归咎于测试设备，样件安装或者操作员的失误的失效不应判定产品不合格。当产品失效发生时，需要有纠正措施以及重新提交样件进行验证。在重新验证前，需确认已有纠正措施。

4.4 Quality conformance inspection 质量合格检验

The applicable TE Connectivity quality inspection plan will specify the sampling acceptable quality level to be used. Dimensional and functional requirements shall be in accordance with the applicable product drawing and this specification.

TE Connectivity 的质量检验计划将指定适用的质量标准。尺寸和功能要求，应按照适用的产品图纸和本规范。

5. APPENDIX 附件

5.1 Derating inside housing 成品温升降额曲线

Derating inside housing: Current at contact and shield

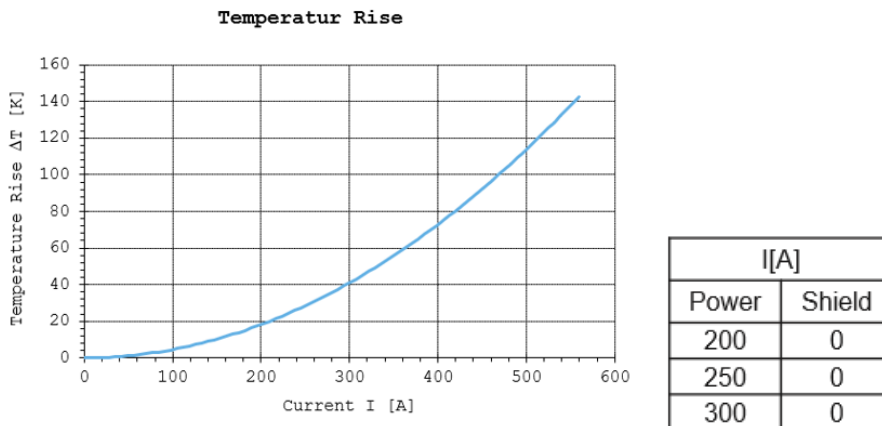

Figure1: Temperature rise without shield current –Header 180deg 1pos +70mm² H+S-Part-No. 84100298.

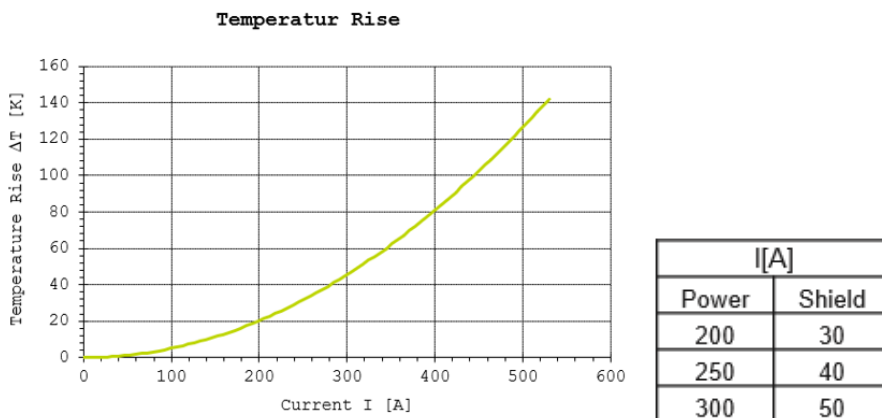
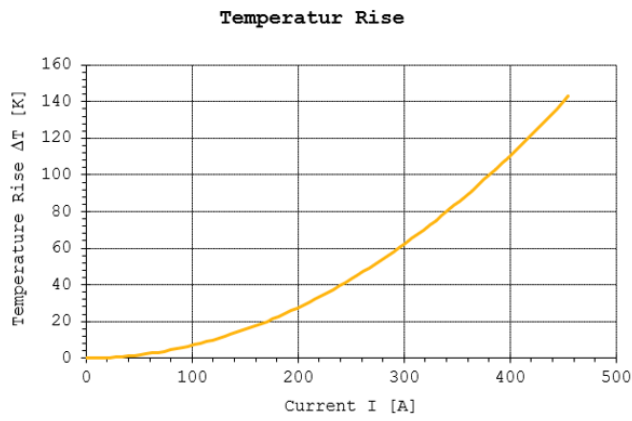
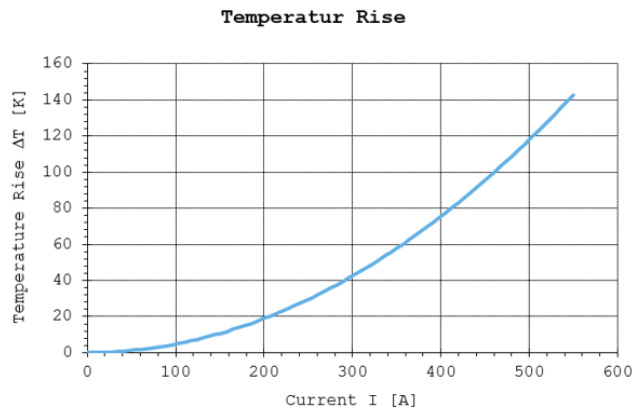

Figure2: Temperature rise with low shield current –Header 180deg 1pos +70mm² H+S-Part-No. 84100298.



I[A]	
Power	Shield
200	60
250	80
300	100

Figure3: Temperature rise with high shield current –Header 180deg 1pos +70mm² H+S-Part-No. 84100298.



I[A]	
Power	Shield
200	0
250	0
300	0

Figure4: Temperature rise without shield current –Header 180deg 2pos +70mm² H+S-Part-No. 84100298.

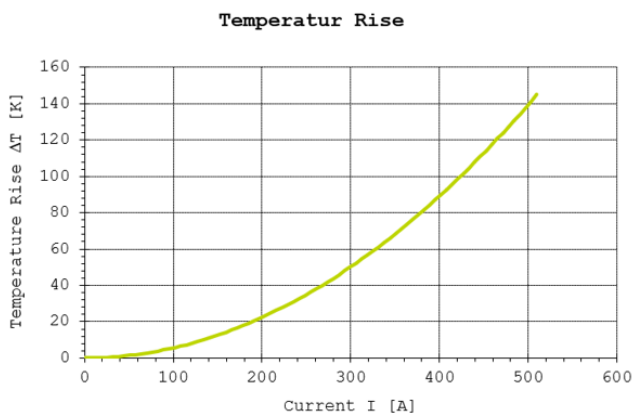

I[A]	
Power	Shield
200	30
250	40
300	50

Figure5: Temperature rise with low shield current –Header 180deg 2pos +70mm² H+S-Part-No. 84100298.

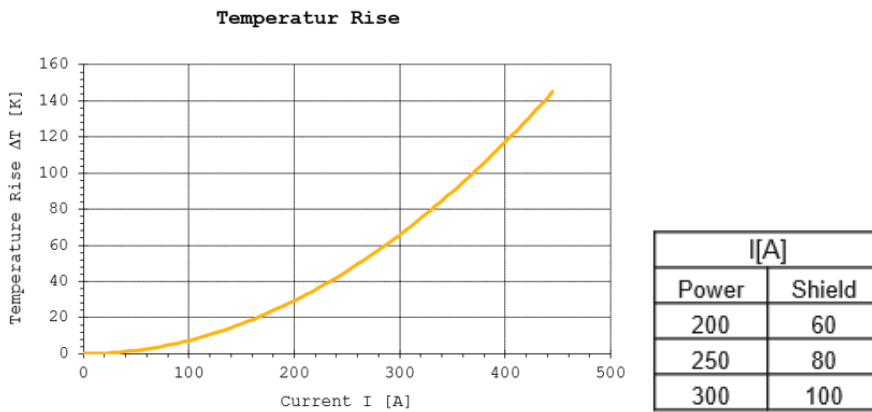

Figure6: Temperature rise with high shield current –Header 180deg 2pos +70mm² H+S-Part-No. 84100298.

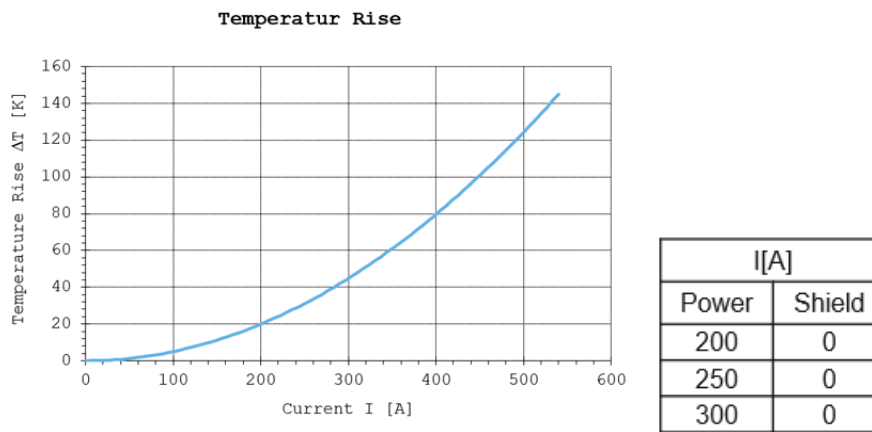

Figure7: Temperature rise without shield current –Header 180deg 3pos +70mm² H+S-Part-No. 84100298.

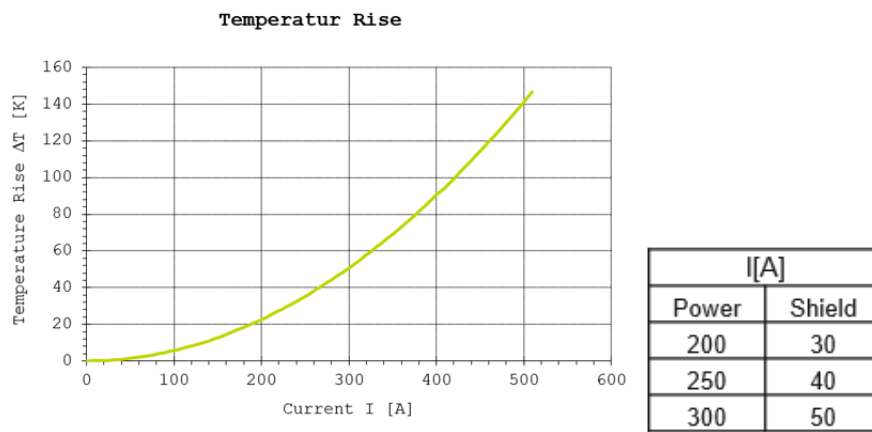
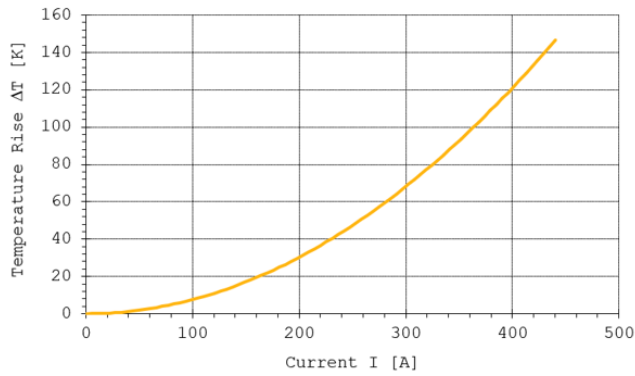

Figure8: Temperature rise with low shield current –Header 180deg 3pos +70mm² H+S-Part-No. 84100298.

Temperatur Rise



I[A]	
Power	Shield
200	60
250	80
300	100

Figure9: Temperature rise with high shield current –Header 180deg 3pos +70mm² H+S-Part-No. 84100298.

Temperatur Rise

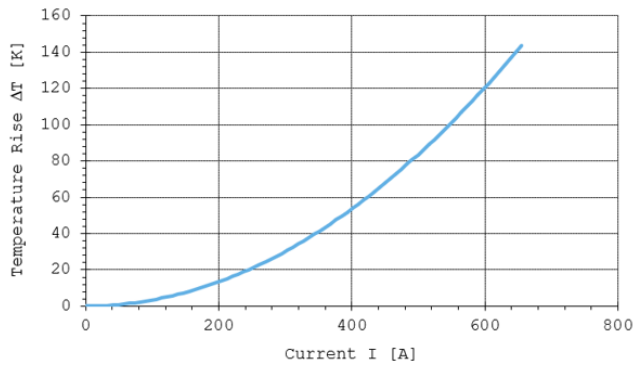

I[A]	
Power	Shield
300	0
350	0
400	0

Figure10: Temperature rise without shield current –Header 180deg 1pos +95mm² H+S-Part-No. 84100299.

Temperatur Rise

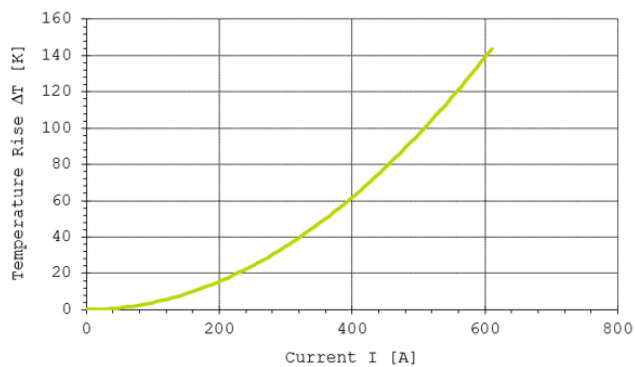

I[A]	
Power	Shield
300	35
350	45
400	55

Figure11: Temperature rise with low shield current –Header 180deg 1pos +95mm² H+S-Part-No. 84100299.

Temperatur Rise

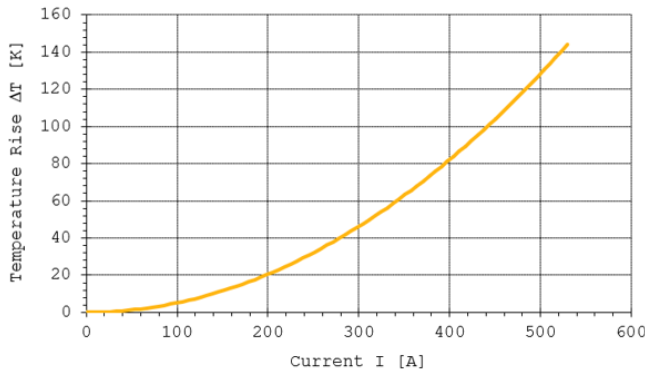

I[A]	
Power	Shield
300	70
350	90
400	110

Figure12: Temperature rise with high shield current –Header 180deg 1pos +95mm² H+S-Part-No. 84100299.

Temperatur Rise

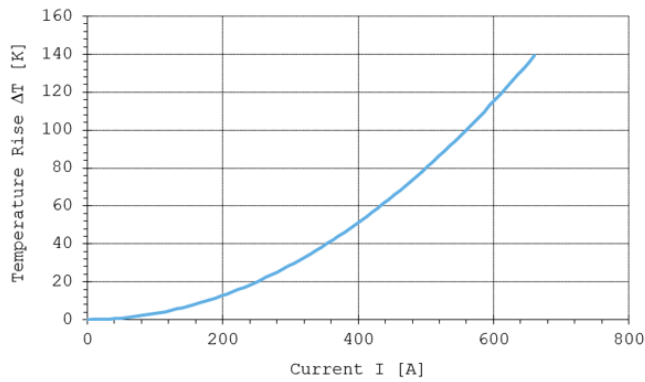

I[A]	
Power	Shield
300	0
350	0
400	0

Figure13: Temperature rise without shield current –Header 180deg 2pos +95mm² H+S-Part-No. 84100299.

Temperatur Rise

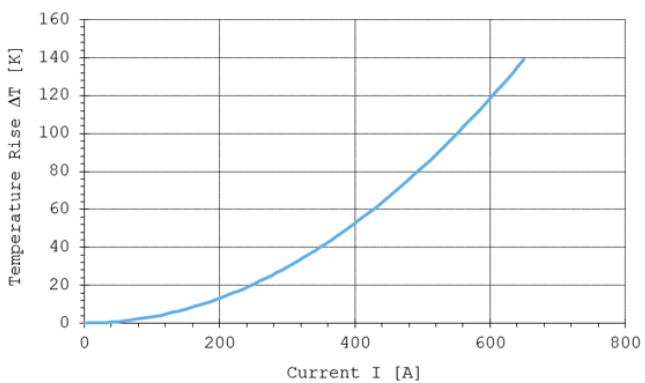

I[A]	
Power	Shield
300	0
350	0
400	0

Figure14: Temperature rise without shield current –Header 180deg 3pos +95mm² H+S-Part-No. 84100299.

Temperatur Rise

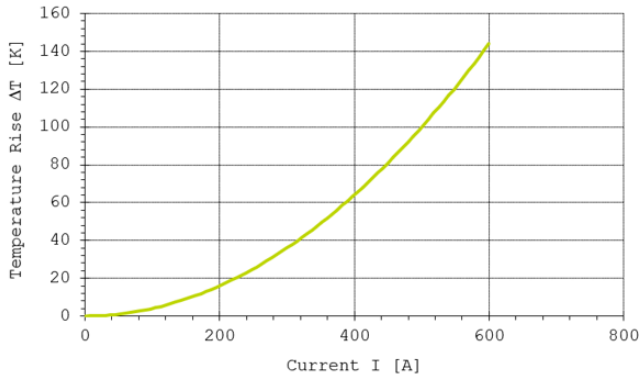

I[A]	
Power	Shield
300	35
350	45
400	55

Figure15: Temperature rise with low shield current –Header 180deg 3pos +95mm² H+S-Part-No. 84100299

Temperatur Rise

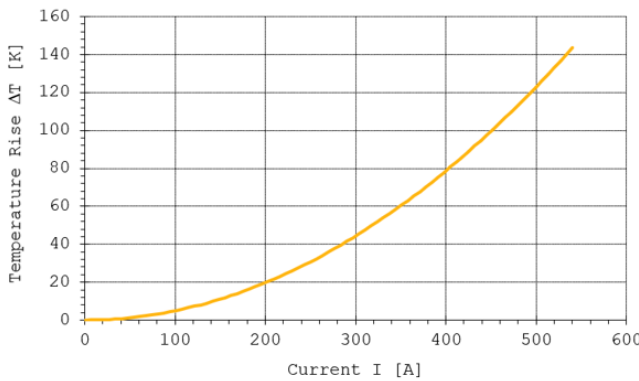

I[A]	
Power	Shield
300	70
350	90
400	110

Figure16: Temperature rise with high shield current –Header 180deg 3pos +95mm² H+S-Part-No. 84100299.

Temperatur Rise

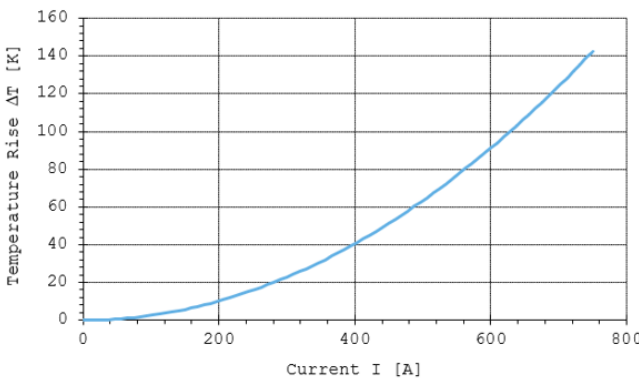

I[A]	
Power	Shield
300	0
400	0
500	0

Figure17: Temperature rise without shield current –Header 180deg 1pos +120mm² H+S-Part-No. 84103410.

Temperatur Rise

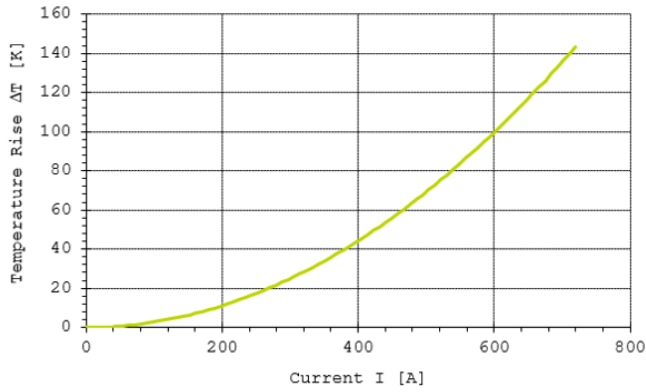

I[A]	
Power	Shield
300	40
400	50
500	60

Figure18: Temperature rise with low shield current –Header 180deg 1pos +120mm² H+S-Part-No. 84103410.

Temperatur Rise

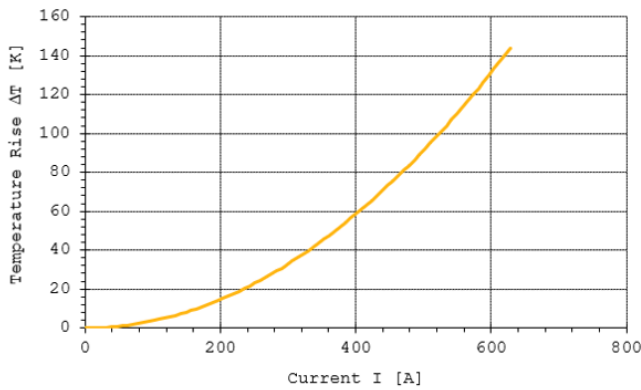

I[A]	
Power	Shield
300	80
400	100
500	120

Figure19: Temperature rise with high shield current –Header 180deg 1pos +120mm² H+S-Part-No. 84103410.

Temperatur Rise

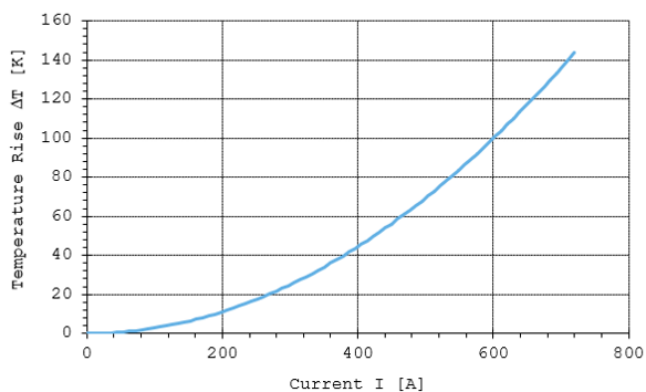

I[A]	
Power	Shield
300	0
400	0
500	0

Figure20: Temperature rise without shield current –Header 180deg 2pos +120mm² H+S-Part-No. 84103410.

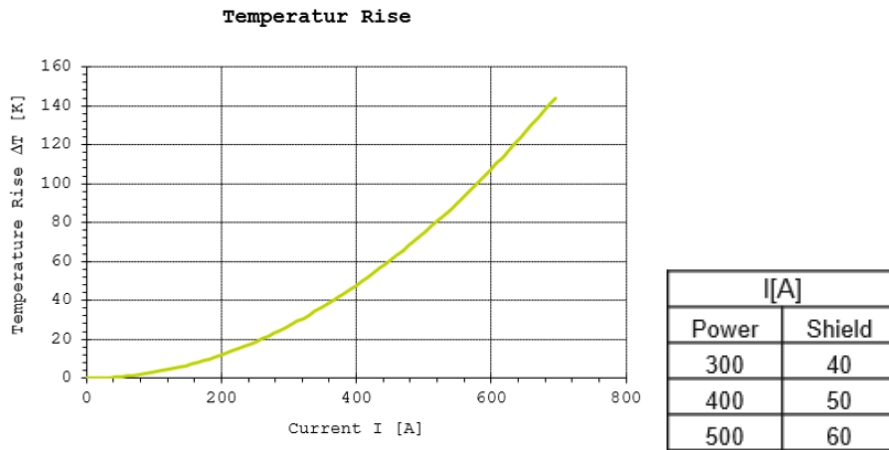

Figure21: Temperature rise with low shield current –Header 180deg 2pos +120mm² H+S-Part-No. 84103410.

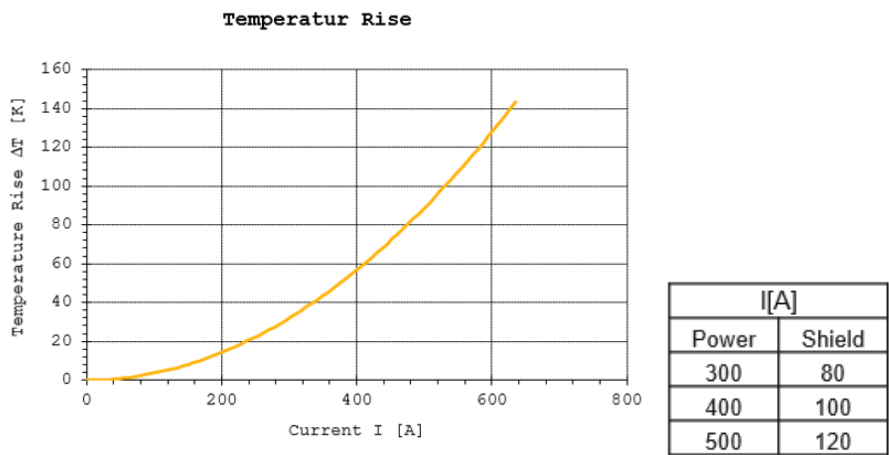

Figure22: Temperature rise with high shield current –Header 180deg 2pos +120mm² H+S-Part-No. 84103410.

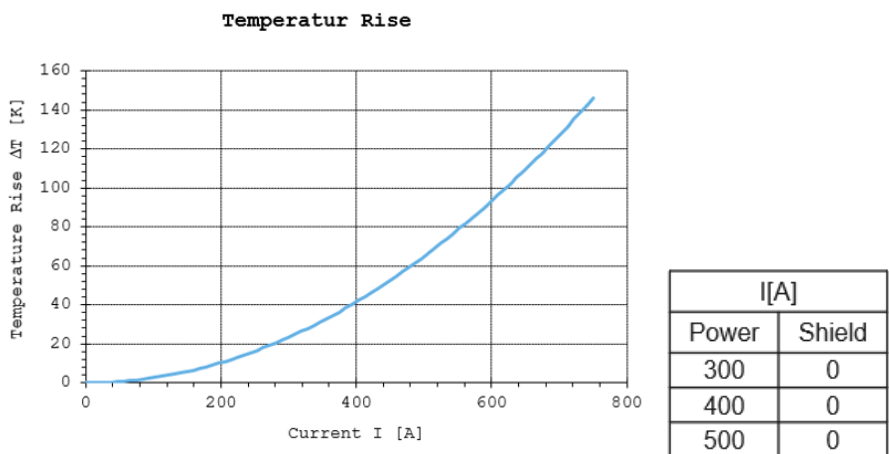
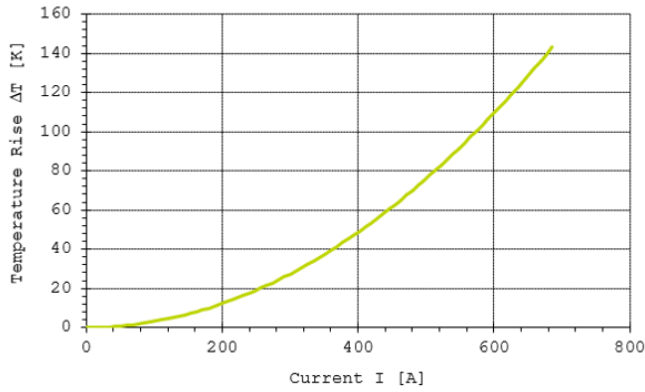

Figure23: Temperature rise without shield current –Header 180deg 3pos +120mm² H+S-Part-No. 84103410.

Temperatur Rise



I[A]	
Power	Shield
300	40
400	50
500	60

Figure24: Temperature rise with low shield current –Header 180deg 3pos +120mm² H+S-Part-No. 84103410.

Temperatur Rise

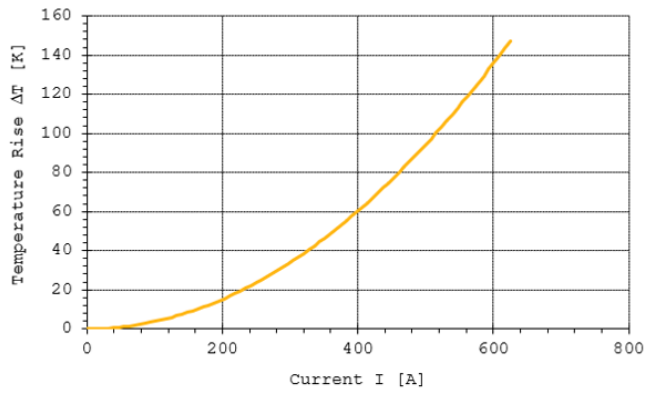

I[A]	
Power	Shield
300	80
400	100
500	120

Figure25: Temperature rise with high shield current –Header 180deg 3pos +120mm² H+S-Part-No. 84103410.

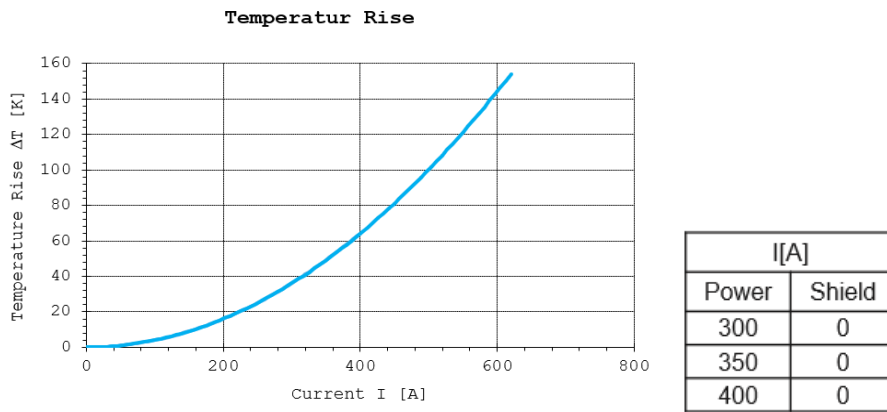

Figure26: Temperature rise without shield current –Header 180deg 3pos +95mm² H+S High Flex-Part-No. 85010928.

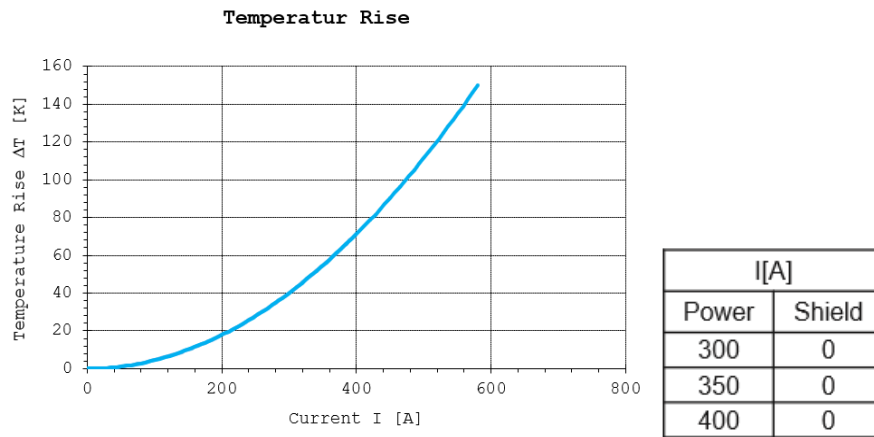

Figure27: Temperature rise without shield current –Header 90deg 3pos +95mm² H+S High Flex-Part-No. 85010928.

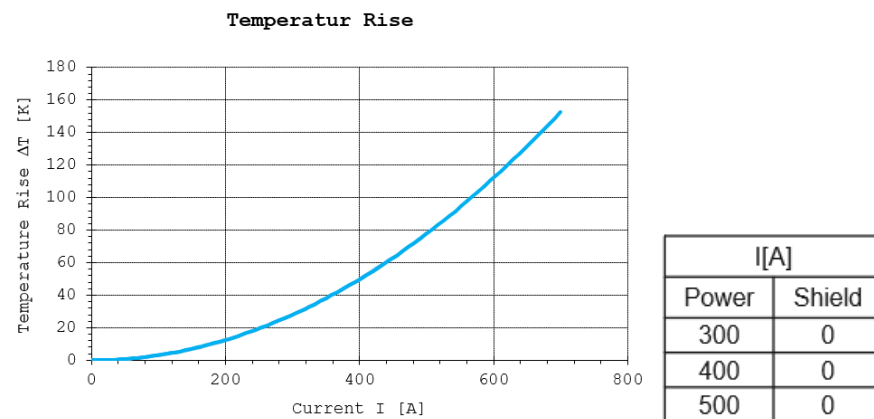
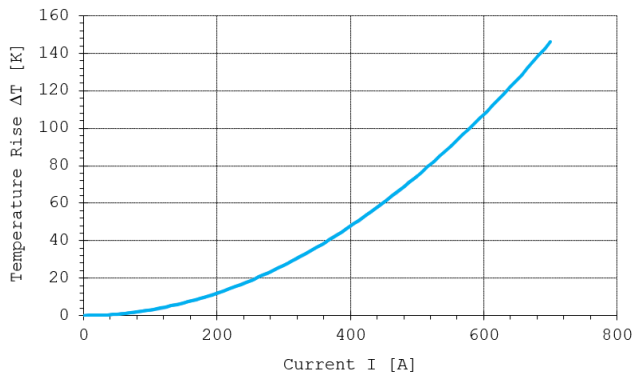

Figure28: Temperature rise without shield current –Header 180deg 3pos +120mm² H+S High Flex-Part-No. 85010929.

Temperatur Rise



I[A]	
Power	Shield
300	0
400	0
500	0

Figure29: Temperature rise without shield current –Header 90deg 3pos +120mm² H+S High Flex-Part-No. 85010929.

Temperatur Rise

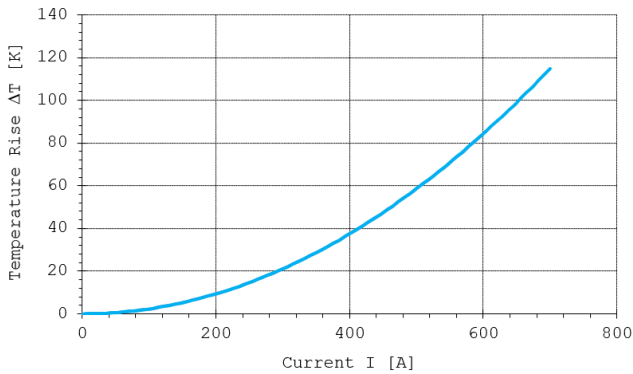

I[A]	
Power	Shield
300	0
450	0
600	0

Figure30: Temperature rise without shield current –Header 180deg 3pos +150mm² H+S High Flex-Part-No. 85163659.

Temperatur Rise

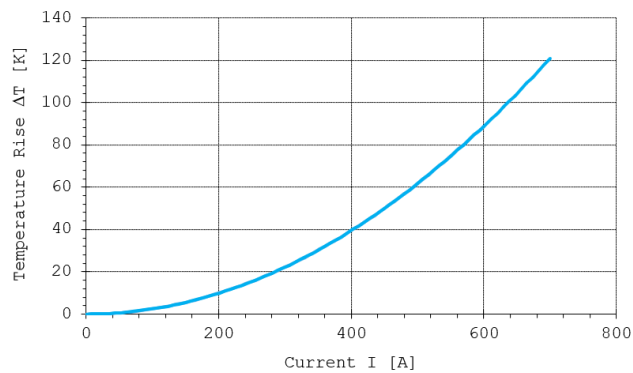

I[A]	
Power	Shield
300	0
450	0
600	0

Figure31: Temperature rise without shield current –Header 90deg 3pos +150mm² H+S High Flex-Part-No. 85163659

5.2 Dynamic load (ISO16750-3) 振动性能 (ISO16750-3)

Dynamic load acc. ISO 16750-3 test VII / IX (released 2012)
 Design of vibration device (see figure 32)
 H+S 150mm² shield high flex cable
 Wire fixation distance is 40mm

振幅依照 ISO 16750-3 测试 7/9 (2012 版)
 振动治具 (如图 32)
 屏蔽线 150 平方毫米标准屏蔽线
 线束固定长度为 40mm

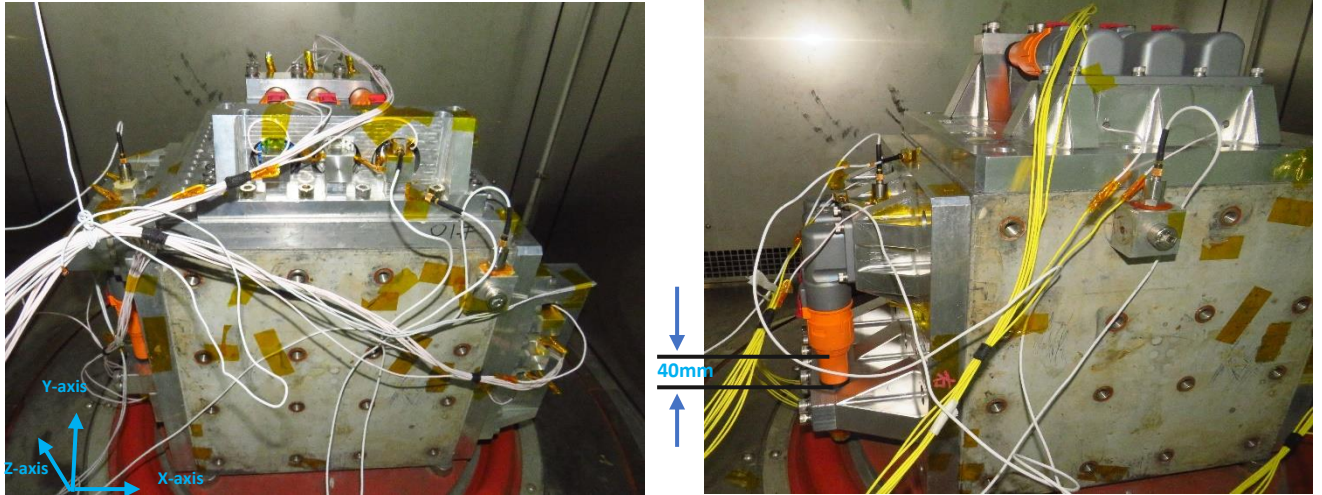

Figure 32 Vibration device set (exemplary view at 3pos header+150mm² connector)

5.3 Contact engagement length 端子接触长度

- | | | | |
|---|----------------------------------|--------|-------|
| A | Contact overlap – Power contact | 电源端子 | ≥ 1mm |
| B | Contact overlap – HVIL contact | 高压互锁端子 | ≥ 1mm |
| C | Contact overlap – Shield contact | 屏蔽接触 | ≥ 1mm |

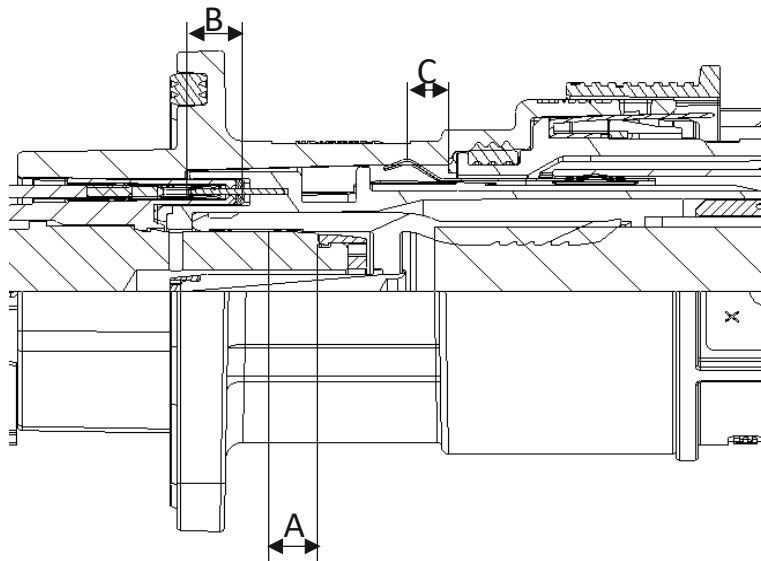

Figure 33 Contact engagement length

5.4 Strain Relief 应力释放

System is validated with strain relief at 40mm. Each application has to be evaluated independently with regards to the external influences on the system. Having strain relief, which moves with the connector body, close to the end of the connector will have a positive influence on the performance of the connector. Having strain relief further from the end of the connector or that moves independent of the connector body will have a negative influence on the performance of the connectors.

系统通过 40mm 的应变消除进行验证。每个应用都必须独立评估对系统的外部影响。随连接器主体移动的压力释放，接近连接器的末端将对连接器的性能产生积极影响。应变释放离连接器的末端更远或者连接器主体晃动将对连接器的性能产生负面影响。

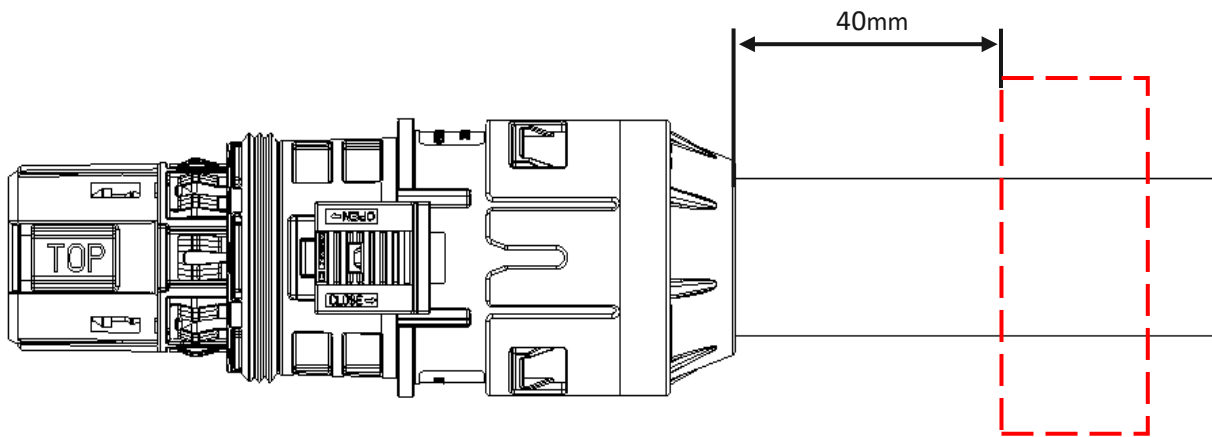

Figure 34 Recommended requirement for strain relief