

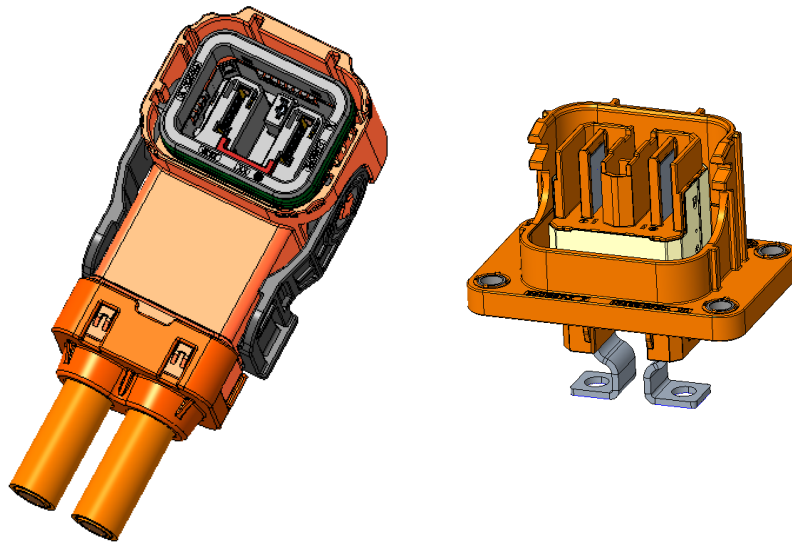

CSJ1200 90° PRODUCT SPECIFICATION

CSJ1200 90° 高压连接器产品规范



				PR: F. SUN DATE:20DEC2023	 TE Shanghai, China		
				CHK: F. MA DATE:20DEC2023			
A	First released	F.S	20DEC2023	APP: E.JIANG DATE:20DEC2023		Document No.: 108-160464	LOC: ES
LTR	REVISION RECORD	PR	DATE				

CONTENT

1. SCOPE 适用范围.....	3
1.1 CONTENT 内容.....	3
1.2 QUALIFICATION 鉴定	3
2. APPLICABLE DOCUMENTS 适用文件.....	3
2.1 USABLE DOCUMENT 使用文件.....	3
2.2 TE SPECIFICATIONS 泰科电子规范	3
2.3 OTHER SPECIFICATIONS 其他规范	3
3. REQUIREMENT 要求.....	4
3.1 DESIGN AND CONSTRUCTION 设计和结构	4
3.2 MATERIAL 材料	4
3.3 TEST PARAMETERS AND TOLERANCES 测试参数与公差	5
3.4 RATINGS 等级	5
3.5 GENERAL PERFORMANCE AND TEST DESCRIPTION 通用性能和试验描述	6
3.6 TEST'S REQUIREMENT AND METHOD SUMMARY 测试要求及方法	6
3.7 ADDITIONAL TEST TESTS REQUIREMENT AND METHOD SUMMARY 附加的测试需求.....	9
3.8 TEST SEQUENCE 试验顺序	10
4. QUALITY 质量	11
4.1 QUALIFICATION TEST 鉴定	11
4.2 REQUALIFICATION TEST 重新鉴定.....	11
4.3 ACCEPTANCE 验收.....	12
4.4 QUALITY CONFORMANCE INSPECTION 质量合格检验.....	12
5. APPENDIX 附件	12
5.1 DERATING INSIDE HOUSING 成品温升降额曲线.....	12
5.2 CONTACT ENGAGEMENT LENGTH 端子接触长度	13
5.3 STRAIN RELIEF 应力释放.....	13

1. SCOPE 适用范围

1.1 Content 内容

This specification covers the performance, test and quality requirements for CSJ1200 Plug90°. According to LV215-2 specifications, for a metric wire size range from 10mm² up to 25mm² acc. to LV216-2

This specification applies to the product 2401661/2401695, but not limited to it.

本规范适用于 CSJ1200 Plug90°(以下简称 CSJ1200 Plug90°) 的性能, 测试和质量要求。CSJ1200 连接器系统的设计符合 LV215-2 规范, 公制线径范围为 10mm²至 25mm² (符合 LV216-2 标准)。

本规范适用但不仅限于以下零件号: 2401661/2401695。

1.2 Qualification 鉴定

When tests are performed, the following specifications and standards shall be used. All inspections shall be performed using the applicable inspection plan and product drawing.

本测试规范依照下面的规范及标准执行。所有的检验应依照合适的检验计划及产品图纸执行。

2. APPLICABLE DOCUMENTS 适用文件

2.1 Usable document 使用文件

In the event of conflict between the requirements of this specification and the drawing, the drawing shall take precedent.

In the event of conflict between the requirement of this specification and the referenced documents, this specification shall take precedent.

在本规范的要求与图纸发生冲突时, 以产品图纸为准。在本规范的要求与参考文件发生冲突时, 以本规范为准。

2.2 TE specifications 泰科电子规范

TEC-109-1: General requirements for Test Specifications / 测试通用规范

2.3 Other specifications 其他规范

Doc number	Edition	Standard: Title, Author
DIN EN 60664-1	2008-01	Isolation coordination for equipment within low voltage systems - Part 1: Principles, requirements and tests
DIN 40050-9	1993-05	Degrees of protection (IP-Code) - Protection of electrical equipment against foreign objects, water and access
ISO 20653	2006-08	Road vehicles – Degrees of protection (IPCode) - Protection of electrical equipment against foreign objects, water and access
ISO 6469-3	2001-01	Electric road vehicles – Safety specifications. Part 3: Protection of person against electric hazards
SAE J 1742	1998-03 (2005-12)	Connections for High Voltage On-Board Road Vehicle, Electrical Wiring Harnesses Test Methods and General Performance Requirements
LV 214-1	2010-03	Test specification for motor vehicle connectors

LV 215-2	2013-02	Electrical/Electronic Requirements of HV Connectors
VW80332	2013-02	Motor Vehicle High-Voltage Contacts
LV216		HV shield cable

3. REQUIREMENT 要求

3.1 Design and Construction 设计和结构

Products must meet the design, construction and physical dimensions specified in the applicable product drawings.

产品必须满足产品图纸上的设计，结构和尺寸要求。

3.2 Material 材料

Description of the material sees the related product drawings.

材料描述见相关产品图纸。

Customer drawing / 客户图	Description / 描述
Plug side product / 母端产品	
2401661	Plug housing assembly for 90DEG
2401674	Inner ferrule
2401675	Out shielding
2401678	Family seal and clip Assy
2401684	Cover
Terminal / 端子	
2400163	CSJ1200 crimp terminal for 90DEG
108-160512	CSJ1200 crimp terminal 108 Spec
114-160283	CSJ1200 crimp terminal 114 Spec
2395928	CSJ1200 weld terminal for 90DEG
108-160918	CSJ1200 weld terminal 108 Spec
114-160770	CSJ1200 weld terminal 114 Spec
Header side product / 公端产品	
2401695	Header assembly
2401703	HVIL housing

963715/928999	MQS terminal
108-18030	MQS terminal 108 Spec
114-18021/114-18025	MQS terminal 114 Spec

3.3 Test parameters and tolerances 测试参数与公差

Table 1: Test parameters and tolerances

Requirement 要求	Tolerance 公差
Ambient temperature 环境温度	23°C ± 5°C
Relative humidity 相对湿度	45% to 75%
Atmospheric pressure 大气压力	96kPa ± 10kPa

3.4 Ratings 等级

- A. Operating Temperature / 工作温度: -40~125°C
- B. Storage Temperature / 储存温度: -40~125°C
- C. Rated voltage / 额定工作电压: 1000VDC
- D. Application / 产品应用: Inverter / Motor / Battery.....

Description	Range
Max. Voltage according DIN EN 60664-1	≤1000VDC
Voltage class acc. ISO 6469-3	B
Class 1 equipment acc. ISO 6469-3	1
Rated surge voltage Dielectric withstand voltage (5500m a.s.l.)	4.3KV
Insulation resistance acc. ISO 6469-3, SAE J 1742	>200MΩ
Isolation Group I acc. DIN EN 60664-1	600≤CTI
Pollution degree acc. DIN EN 60664-1	2
Ambient temperature	-40°C to 125°C
Degrees of protection (IP-Code) against access acc. ISO 20653	IPXXB
Degrees of protection (IP-Code) against foreign objects and water acc. ISO 20653	IPX9K, IPX8
Color of plastic housing	Orange similar RAL 2003
Durability mating cycle	≤ 50

3.5 General Performance and Test description 通用性能和试验描述

The product is designed to meet the electrical, mechanical and environmental performance requirements specified in Para.4. All testes must be performed at the test condition of the TE test specification 109-1 unless otherwise specified.

产品应能满足段落 4 中的电气，机械和环境等性能要求。所有试验均需按照 TE 规范 109-1 中的测试条件进行，除非另有说明。

3.6 Test's requirement and method summary 测试要求及方法

Not shown test-details see LV 214 (release 2010-03) and LV215-2 (release 2013-02)

Table 2: Test Requirements and Procedures Summary

Item	Test Description	Requirement	Procedure
PG0 RECEIVING INSPECTION			
3.6.1	E 0.1 Visual inspection	Basic function proven	LV215-2 DIN EN 60512-1-1
3.6.2	E 0.2 Contact resistance	Contact (total resistance including crimp/welding connection): 10mm ² ≤ 0.17mΩ; 16mm ² ≤ 0.15mΩ; 25mm ² ≤ 0.14mΩ Shield ≤ 7mΩ; HVIL ≤ 15mΩ	LV215-2 DIN EN 60512-1-1
3.6.3	E 0.3 Insulation resistance	Insulation resistance at 1k VDC: > 200MΩ	LV215-2 DIN EN 60512-3-1
3.6.4	E 0.4 Dielectric strength	DC4300V 60S Leakage current < 10mA	LV215-2 DIN EN 60512-3-1
PG 4 CONTACT OVERLAPPING			
3.6.5	E 4.1 Contact engagement length	Values see appendix 5.3	Theoretical study
PG 6 INTERACTION BETWEEN CONTACT AND HOUSING			
3.6.6	Actuation forces of the secondary locking device	TPA closing force < 50N TPA open force: 10~50N	LV215-2 DIN EN 60068-2-31
3.6.7	B 6.1 Drop test	Drop test from 1m height; No damages or impairments of function	LV215-2 DIN EN 60068-2-31
PG7 HANDING AND FUNCTIONAL RELIABILITY OF THE HOUSINGS			
3.6.8	E 7.1 Error-proof design of housings	Coding/Polarization Test load: 80N	LV214 DIN EN 60512-13-5

3.6.9	E 7.2 Retention force of the housing latch/lock	Retention force of the housing latch mechanism/housing interlock: > 150N	LV215-2 DIN EN 60512-15-6
3.6.10	E 7.3 Functionality of CPA	Actuation force to close: 5-30N Close to pre-set force: 5-30N CPA Efficiency: > 80N	DIN EN 60512-15-6
3.6.11	E 7.4 Insertion force or actuation force for insertion with removal aids	Insertion and actuation force: ≤ 75N	DIN EN 60512-15-6
PG 8 MATING AND RETENTION FORCE OF CONTACT PARTS			
3.6.12	E 8.1 Contact insertion forces	Cable assy with CSJ1200-Contact: Insertion force ≤ 60N	LV214
3.6.13	E 8.2 Contact removal force from the housing	TPA lock measured Cable assy with CSJ1200-contact ≥ 250N HVIL-contact ≥ 55N	LV214
PG 11 MATING CYCLES			
3.6.14	B 11.1 Mating cycles	Connector with HVIL-Contacts: 50 Cycles Insertion and actuation force: ≤ 75N	LV214
PG 13 HOUSING INFLUENCE ON THE DERATING			
3.6.15	E 13.2 Derating with housing	Dependent on application and cable type different values are possible Max. temperature at contacts 180°C Derating see appendix 5.1	LV215-2 DIN EN 60512-5-1/2
PG 17 DYNAMIC LOAD			
3.6.16	B 17.2 Dynamic Load Broad-band random	Severity 2: "Body" sealed; Details see appendix 5.2 Slight wear, surface ok. Resistances after testing <ul style="list-style-type: none"> ● Contact ≤ 0.34mΩ(10mm²) ● Contact ≤ 0.30mΩ(16mm²) ● Contact ≤ 0.28mΩ(25mm²) ● HVIL-Contact ≤ 15mΩ; ● Shielding cable – aggregate < 7mΩ 	LV214 DIN EN 60068-2-64

3.6.17	B 17.3 Endurance shock test	30g; T=6ms; N=6000 Slight wear, surface ok. Resistances after testing <ul style="list-style-type: none"> ● Contact $\leq 0.34\text{m}\Omega(10\text{mm}^2)$ Contact $\leq 0.30\text{m}\Omega(16\text{mm}^2)$ Contact $\leq 0.28\text{m}\Omega(25\text{mm}^2)$ ● HVIL-Contact $\leq 15\text{m}\Omega$; ● Shielding cable – aggregate $< 7\text{m}\Omega$ 	LV214 DIN EN 60068-2-27
PG 18A DICING SALT LOAD			
3.6.18	B 18.2 Salt spray, cyclic	Resistances after Salt spray test, not sealed <ul style="list-style-type: none"> ● Contact $\leq 0.34\text{m}\Omega(10\text{mm}^2)$; $\leq 0.30\text{m}\Omega(16\text{mm}^2)$; $\leq 0.28\text{m}\Omega(25\text{mm}^2)$ ● HVIL-Contact $\leq 15\text{m}\Omega$; ● Shielding cable – aggregate $< 7\text{m}\Omega$ 	LV215-2 DIN EN 60068-2-52 (SG3)
PG 20 CLIMATIC LOAD OF HOUSINGS			
3.6.19	B 20.1 Dry heat	Dry heat 120h / 125°C	LV214
3.6.20	B 20.2 Damp heat	Damp heat 10 days / 40°C / 95% rel. humidity Insulation resistance at 1k VDC: $> 200\text{M}\Omega$	LV214
3.6.21	B 20.3 Climatic cold	Climatic cold 48h / -40°C Plugging / unmating possible at -20°C	LV214
3.6.22	B 20.1 Dry heat	Dry heat 48h / 80°C	LV214
3.6.23	B 6.1 Drop test after aging	Drop test from 1m height; No damages or impairments of function	LV215-2 DIN EN 60068-2-31
PG 21 LONG-TERM AGING			
3.6.24	B 21.1 Long-term aging in dry heat	1000h at 125°C; Resistances after aging: <ul style="list-style-type: none"> ● Contact $\leq 0.34\text{m}\Omega(10\text{mm}^2)$; $\leq 0.30\text{m}\Omega(16\text{mm}^2)$; $\leq 0.28\text{m}\Omega(25\text{mm}^2)$ ● HVIL-Contact $\leq 15\text{m}\Omega$ ● Shielding cable – aggregate $< 7\text{m}\Omega$ Functionality; Contact Removal forces acc. E8.2	LV215-2 DIN EN 60068-2-2
PG 22B CHEMICAL RESISTANCE			
3.6.25	B 22.1B Chemical Resistance (water-tight design)	Application of media for 48h at specified temperature; only tested at single parts No textural or dimensional change, no impairments of function Insulation resistance $> 100\text{M}\Omega$	LV214

PG 23 WATER - TIGHTNESS			
3.6.26	B 19.3 Aging in dry heat	120h at 125°C	DIN EN 60068-2-2
3.6.27	B 19.1 Temperature shock	Period: 144 cycles -40°C / +125°C each 15min	DIN EN 60068-2-14
3.6.28	B 23.1 Immersion with pressure difference	Low pressure: -10kPa, holding time 5min. -50kPa, holding time 5min. Change in pressure:10 kPa/min	LV214 DIN EN 60512-14-5
3.6.29	B 23.2 Immersion with pressure difference	Movement of cable at low pressure: -10kPa, holding time 5min. -50kPa, holding time 5min.	LV214 DIN EN 60512-14-5
3.6.30	B 23.3 Thermal shock test	30min. in 125°C air; 15min in 0°C Water. 5 cycles	LV214
3.6.31	B 23.4 Degree of protection test / pressure washer test	Severity: IP X9K Test duration per side: 15s Distance to nozzle: 10-15cm Pressure: 80 bar Temperature: 80°C	LV214 DIN 40050-9
3.6.32	E 0.3 Insulation resistance	Insulation resistance at 1000VDC: >200MΩ	LV215-2 DIN EN 60512-3-1
PG 50 EMC – ELECTROMAGNETIC COMPATIBILITY			
3.6.33	PG 50 EMC- Electromagnetic compatibility	Frequency	Delta-Transfer impedance
		2MHz	<10mΩ
		30MHz	<50mΩ
VG 95214-11 LV215-1 LV215-2			
PG 51 IP PROTECTION OPEN CONNECTOR			
3.6.34	PG51 Protection open connector	IP-Protection IPXXB, un-mated (VDE test finger ø12mm) IP-Protection IPXXD, mated	ISO 20653

3.7 Additional test Tests requirement and method summary 附加的测试需求

Table 3: Additional test requirements

Items	Test Description	Requirement	Procedure

3.6.35	A1 Crimp validation PG1	Pull out force of shield crimp: >150N Cross section examination: crimp sleeves are well formed	TE-Spec. 109-18212
3.6.36	A2 Crimp validation PG2	Shield resistance: < 3mΩ	TE-Spec. 109-18212
3.6.37	A5 Retention force further connector parts	Shut bar retention force: > 30N Retainer retention force: > 50N Bushing retention force: > 30N MQS housing retention force: > 60N	DIN IEC 60512-8
3.6.38	A6 Insertion force further connector parts	MQS housing insertion force: 10N<F<50N	DIN IEC 60512-8

3.8 Test sequence 试验顺序

Test or Examination	Test group and sequence (PG)														
	0	4	6	7	8	11	13	17	18	20	21	22	23	50	51
3.6.1 Visual examination	1	1	1	1	1	1,5	1	1,7	1,5	1,6 ,8	1,7	1,5	1,4, 10	1	1
3.6.2 Contact resistance	2					2,4		2,4 ,6	2,4		2,4			2	
3.6.3 Isolation resistance	3		3							2,5	5	2,4			
3.6.4 Dielectric withstand	4														
3.6.5 Contact engagement length															
3.6.6 Actuation forces of the secondary locking device			4												
3.6.7 Drop test			2												
3.6.8 Error-proof design of housings				2											
3.6.9 Retention force of the housing latch/lock				3											
3.6.10 Functionality of CPA				4											
3.6.11 Insertion force or actuation force for insertion with removal aids				5											
3.6.12 Contact insertion forces					2										
3.6.13 Contact removal force from the housing					3										
3.6.14 Mating cycles						3									
3.6.15 Derating with housing							2								
3.6.16 Dynamic Load Broad-band random								3							
3.6.17 Endurance shock test								5							
3.6.18 Salt spray, cyclic									3						
3.6.19 Dry heat										3					

4.3 Acceptance 验收

Acceptance is based on verification that the product meets the requirements of section **Error! Reference source not found.** Failures attributed to equipment, test setup, or operator deficiencies shall not disqualify the product. When product failure occurs, corrective action shall be taken and samples resubmitted for qualification. Testing to confirm corrective action is required before resubmitted.

归咎于测试设备，样件安装或者操作员的失误的失效不应判定产品不合格。当产品失效发生时，需要有纠正措施以及重新提交样件进行验证。在重新验证前，需确认已有纠正措施。

4.4 Quality conformance inspection 质量合格检验

The applicable TE Connectivity quality inspection plan will specify the sampling acceptable quality level to be used. Dimensional and functional requirements shall be in accordance with the applicable product drawing and this specification

TE Connectivity 的质量检验计划将指定适用的质量标准。尺寸和功能要求，应按照适用的产品图纸和本规范。

5. APPENDIX 附件

5.1 Derating inside housing 成品温升降额曲线

Derating inside housing: Current at contact and shield, shield with 0A

Force 25mm² /16mm² /10mm² shield Cu cable, cable length 1.4 m

80% Characteristic curve of measured value

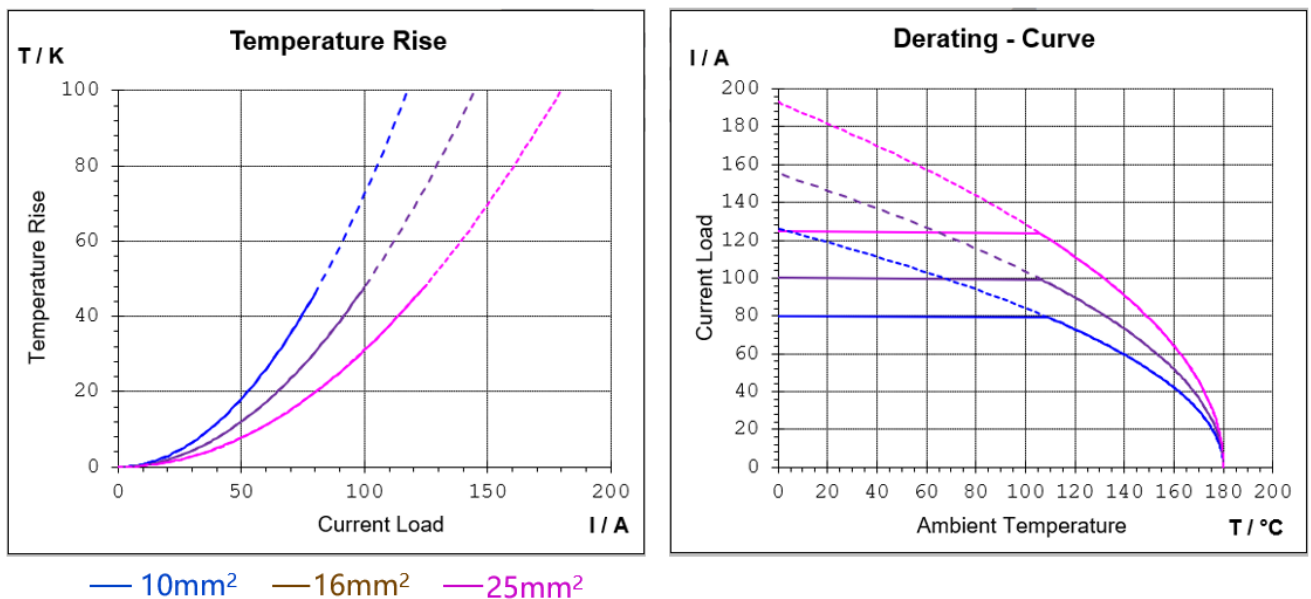
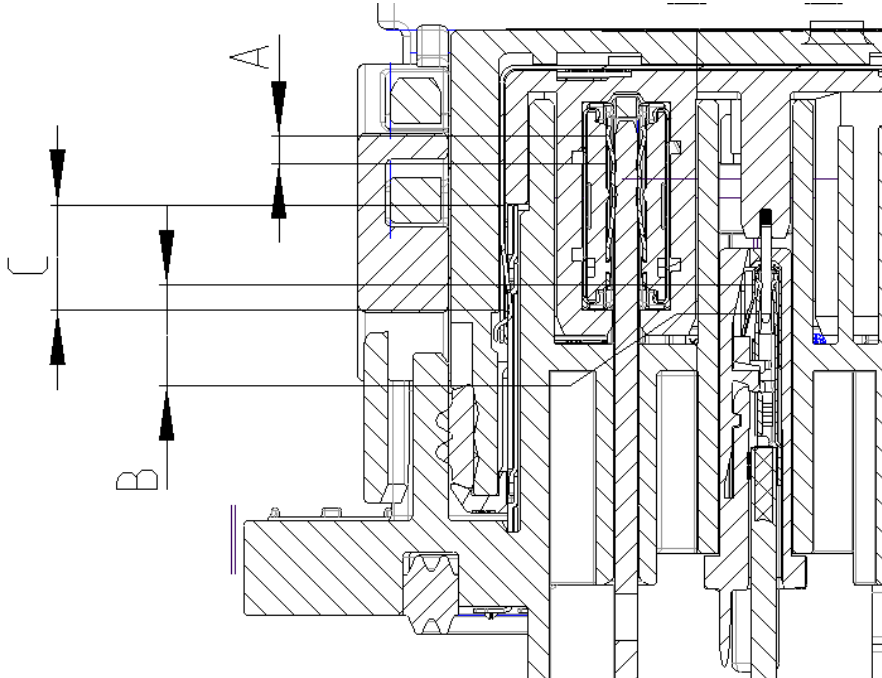

Figure1: Shield Cu cable derating and temperature rise

5.2 Contact engagement length 端子接触长度

A	Contact overlap – Power contact	电源端子	$\geq 1\text{mm}$
B	Contact overlap – HVIL contact	高压互锁端子	$\geq 1\text{mm}$
C	Contact overlap – Shield contact	屏蔽接触	$\geq 1\text{mm}$



5.3 Strain Relief 应力释放

System is validated with strain relief at 100mm. Each application has to be evaluated independently with regards to the external influences on the system. Having strain relief, which moves with the connector body, close to the end of the connector will have a positive influence on the performance of the connector. Have strain relief further from the end of the connector or that moves independent of the connector body will have a negative influence on the performance of the connectors.

系统通过 100mm 的应变消除进行验证。每个应用都必须独立评估对系统的外部影响。随连接器主体移动的压力释放，接近连接器的末端将对连接器的性能产生积极影响。应变释放离连接器的末端更远或者连接器主体晃动将对连接器的性能产生负面影响。

