

CSJ21 2POS 90DEG WELDING PRODUCT SPECIFICATION

CSJ21 两位 90 度焊接版高压大电流连接器 产品规范

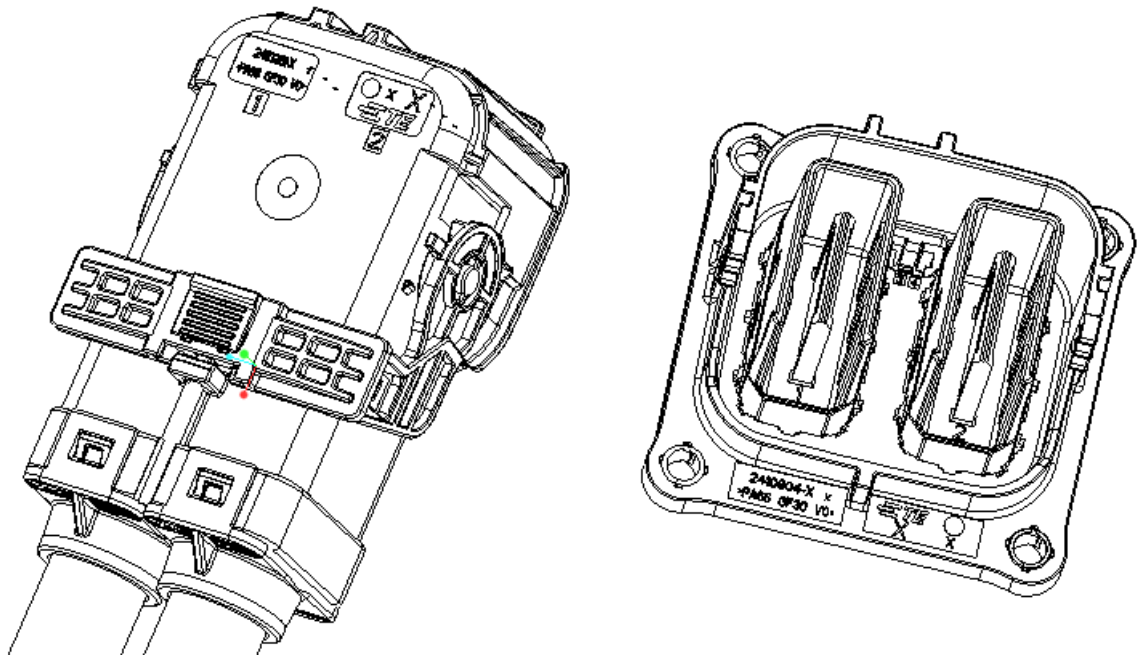

				PR: W.ZHAO DATE:26JUN2022	 TE Shanghai, China		
				CHK: F.MA DATE:26JUN2022			
A	Initial released	W.Z	26JUN26	APP: E.JIANG DATE:26JUN2022	Document No.:	LOC:	REV:
LTR	REVISION RECORD	PR	DATE		108-160466	ES	A

CONTENT

1. SCOPE 适用范围.....	3
1.1 CONTENT 内容.....	3
1.2 QUALIFICATION 鉴定	3
2. APPLICABLE DOCUMENTS 适用文件.....	3
2.1 USABLE DOCUMENT 使用文件.....	3
2.2 TE SPECIFICATIONS 泰科电子规范	3
2.3 CUSTOMER DRAWINGS	4
2.4 SPECIFICATIONS 规范.....	7
2.5 OTHER SPECIFICATIONS 其他规范	7
3. REQUIREMENT 要求.....	8
3.1 DESIGN AND CONSTRUCTION 设计和结构	8
3.2 MATERIAL 材料	8
3.3 TEST PARAMETERS AND TOLERANCES 测试参数与公差	8
3.4 RATINGS 等级	8
3.5 GENERAL PERFORMANCE AND TEST DESCRIPTION 通用性能和试验描述	9
3.6 TESTS REQUIREMENT AND PROCEDURES SUMMARY 测试要求及方法.....	9
3.7 ADDITIONAL TEST PROCEDURES AND TEST RESULTS 附加的测试方法和结果	12
3.8 TEST SEQUENCE 试验顺序	13
4. QUALITY 质量	14
4.1 QUALIFICATION TEST 鉴定	14
4.2 REQUALIFICATION TEST 重新鉴定.....	14
4.3 ACCEPTANCE 验收.....	14
4.4 QUALITY CONFORMANCE INSPECTION 质量合格检验.....	14
5. APPENDIX 附件	15
5.1 DERATING INSIDE HOUSING 成品温升降额曲线.....	15
5.2 DYNAMIC LOAD (LV215 S2) 震动性能(LV215 S2).....	17
5.3 CONTACT ENGAGEMENT LENGTH 端子接触长度	18
5.4 STRAIN RELIEF 应力释放.....	19

1. SCOPE 适用范围

1.1 Content 内容

TE Connectivity's touch-proof 2 position high current connector CSJ21 and header are designed to meet WG 4.3.3, LV215 specifications, for a metric wire size range from 50mm² up to 95mm² acc. to LV216-2.

With a 90° cable outlet incorporates the sealed connector system two 21mm Power contacts and an integrated High Voltage Interlock (HVIL) System. The CSJ21 connector is available for four different keying or polarizing configurations and incorporates 360° conductive EMI shields to reduce radiated emissions in the application. Assembly is simplified with a lever assist for low insertion force and the housings are molded in orange to denote a high voltage system.

泰科电子的两位防触摸大电流连接器 CSJ21 公母端，设计符合 WG 4.3.3, LV215 标准，适用符合 LV216-2 的公制 50mm²到 95mm²平方的电缆

密封连接系统采用 90°出线，两路 21mm 电源连接和一个高压互锁系统。CSJ21 连接器有四种不同的键位，并采用 360 度导电 EMI 屏蔽以减少应用中的辐射。采用杠杆辅助装置，简化装配、降低插拔力，壳体采用橙色警示色代表高压系统

This specification covers the performance, test and quality requirements for TE Connectivity 2 position high current connector CSJ21 with 90° Plug and header assembly. (hereinafter referred to as CSJ21).

本规范适用于泰科电子 CSJ21 两位 90 度高压大电流公母连接器(以下简称 CSJ21) 的性能，测试和质量要求。

1.2 Qualification 鉴定

When tests are performed, the following specifications and standards shall be used. All inspections shall be performed using the applicable inspection plan and product drawing.

本测试规范依照下面的规范及标准执行。所有的检验应依照合适的检验计划及产品图纸执行。

2. APPLICABLE DOCUMENTS 适用文件

2.1 Usable document 使用文件

In the event of conflict between the requirements of this specification and the drawing, the drawing shall take precedent.

In the event of conflict between the requirement of this specification and the referenced documents, this specification shall take precedent.

在本规范的要求与图纸发生冲突时，以产品图纸为准。在本规范的要求与参考文件发生冲突时，以本规范为准。

2.2 TE specifications 泰科电子规范

TEC-109-1: General requirements for Test Specifications / 测试通用规范

2.3 Customer drawings

Table 1: Customer drawings / 客户图纸

Shielding Header side (Include interface) / 公端(包括应用面板)	
2410759	2POS,21MM,HEADER HSG,ASSY
2421867	2POS,21MM,HEADER HSG,ASSY
2461281	2POS,21MM,HEADER HSG,ASSY
2428604	2POS,21MM,HEADER HSG,ASSY
2468601	2POS,21MM,HEADER HSG,ASSY

Unshielding Header side (Include interface) / 公端(包括应用面板)	
2396301	2POS,21MM,HEADER HSG,ASSY
2465622	2POS,21MM,HEADER HSG,ASSY
2425549	2POS,21MM,HEADER HSG,ASSY
2437237	2POS,21MM,HEADER HSG,ASSY
2466140	2POS,21MM,HEADER HSG,ASSY

Shielding Plug side / 屏蔽母端	
2410149	2POS,21MM,PLUG HSG,90 DEG,ASSY,WELDING,SEALED
2395934	90DEG CSJ21 CONTACT
2410194	GASKET RING
2410192	SHIELD CRIMP FERRULE
2410146	2POS,21MM,CABLE CLIP
2414214	2POS,21MM,CABLE SEAL
2415510	2POS,21MM,CABLE SEAL COVER

Shielding Plug side (Anti-oblique insertion) / 屏蔽母端 (防斜插)	
2468134	2POS,21MM,PLUG HSG,90 DEG,ASSY,WELDING,SEALED
2395934	90DEG CSJ21 CONTACT
2410194	GASKET RING
2410192	SHIELD CRIMP FERRULE
2410146	2POS,21MM,CABLE CLIP
2414214	2POS,21MM,CABLE SEAL
2415510	2POS,21MM,CABLE SEAL COVER

Unshielding Plug side / 非屏蔽母端	
2400024	2POS,21MM,PLUG HSG,90 DEG,ASSY,SEALED,UNHSIELDING
2395934	90DEG CSJ21 CONTACT WELDING
2400065	2POS,21MM,CABLE SEAL
2400093	2POS,21MM,CABLE CLIP
2400046	2POS,21MM,CABLE SEAL COVER

Unshielding Plug side (Anti-oblique insertion) / 非屏蔽母端 (防斜插)	
2468133	2POS,21MM,PLUG HSG,90 DEG,ASSY,SEALED,UNHSIELDING
2395934	90DEG CSJ21 CONTACT WELDING
2400065	2POS,21MM,CABLE SEAL
2400093	2POS,21MM,CABLE CLIP
2400046	2POS,21MM,CABLE SEAL COVER

2.4 Specifications 规范

Table 2: TE-specifications / 泰科规范

Specifications	Description
108-160412	Product Specification CSJ21 Contact 90DEG
108-18030	Product Specification MQS Contact system
114-160251	Application Specification CSJ21 2Pos 90°
114-160227	Application Specification CSJ21 Contact 90DED
114-18021	Application Specification MQS Contact system

2.5 Other Specifications 其他规范

Table 3: Other Specifications

Doc number	Edition	Standard: Title, Author
DIN EN 60664-1	2008-01	Isolation coordination for equipment within lowvoltage systems - Part 1: Principles, requirements and tests
DIN 40050-9	1993-05	Degrees of protection (IP-Code) - Protection of electrical equipment against foreign objects, water and access
ISO 20653	2006-08	Road vehicles – Degrees of protection (IPCode) - Protection of electrical equipment against foreign objects, water and access
ISO 6469-3	2001-01	Electric road vehicles – Safety specifications. Part 3: Protection of person against electric hazards
ISO 16750	-1: 2006-01 -2: 2010-03 -3: 2007-07 -4: 2010-04 -5: 2010-04	Electric road vehicles – Environmental conditions and testing for electrical and electronic equipment
SAE J 1742	1998-03 (2005-12)	Connections for High Voltage On-Board Road Vehicle, Electrical Wiring Harnesses Test Methods and General Performance Requirements
LV 214-1	2010-03	Test specification for motor vehicle connectors
LV215-1	2009-02	Electrical/Electronic Requirements of HV Connectors
VW80332	2021-02	Motor Vehicle High-Voltage Contacts
UL2231-2	2012-09	Personnel Protection Systems for Electric Vehicle (EV) Supply Circuits
LV216		HV shield cable

3. REQUIREMENT 要求

3.1 Design and Construction 设计和结构

Products must meet the design, construction and physical dimensions specified in the applicable product drawings.

产品必须满足产品图纸上的设计，结构和尺寸要求。

3.2 Material 材料

Description of the material sees the related customer drawings.

材料描述见相关客户图纸。

3.3 Test parameters and tolerances 测试参数与公差

Table 4: Test parameters and tolerances

Requirement 要求	Tolerance 公差
Ambient temperature 环境温度	23°C ± 5°C
Relative humidity 相对湿度	45% to 75%
Atmospheric pressure 大气压力	100kPa ± 10kPa

3.4 Ratings 等级

Table 5: Product Ratings / 产品等级

Description	Range
Max. Voltage according DIN EN 60664-1	≤1000VDC
Voltage class acc. ISO 6469-3	B
Class 1 equipment acc. ISO 6469-3	1
Dielectric withstand voltage acc. ISO 6469-3, SAE J 1742	3000V
Insulation resistance acc. ISO 6469-3, SAE J 1742	>200MΩ
Isolation Group I acc. DIN EN 60664-1	600≤CTI
Pollution degree acc. DIN EN 60664-1	2
Ambient temperature	-40°C to 125°C
Degrees of protection (IP-Code) against access acc. ISO 20653	IPXXB
Personnel Protection Systems for Electric Vehicle (EV) Supply Circuits	UL finger protection
Degrees of protection (IP-Code) against foreign objects and water acc. ISO 20653	IPX9K,IP67

Color of plastic housing	Orange similar RAL 2003
Durability mating cycle	≥20

3.5 General Performance and Test description 通用性能和试验描述

The product is designed to meet the electrical, mechanical and environmental performance requirements specified in table 6 and table 7. All testes must be performed at the test condition of the TE test specification TEC-109-1 unless otherwise specified.

产品应能满足表 6 和表 7 中的电气，机械和环境等性能要求。所有试验均需按照 TE 规范 TEC-109-1 中的测试条件进行，除非另有说明。

3.6 Tests requirement and procedures summary 测试要求及方法

Not shown test-details see LV 214 (release 2010-03) and LV215-2 (release 2013-03)

Table 6: Test Requirements and Procedures Summary

Test Description	Requirement	Procedure
PG0 RECEIVING INSPECTION		
E 0.1 Visual inspection	Basic function proven	LV215-2 DIN EN 60512-1-1
E 0.2 Contact resistance	Contact(total resistance including crimp connection): 70mm ² ≤0.12mΩ; 95mm ² ≤0.11mΩ;50 mm ² ≤0.13mΩ Shield≤7mΩ; HVIL≤15mΩ	LV215-2 DIN EN 60512-1-1
E 0.3 Insulation resistance	Insulation resistance at 1kVDC: > 200MΩ	LV215-2 DIN EN 60512-3-1
PG 4 CONTACT OVERLAPPING		
E 4.1 Contact engagement length	Values see appendix 5.3	Theoretical study
PG 6 INTERACTION BETWEEN CONTACT AND HOUSING		
E 6.1 Deflection of contacts in the housing cavity	No damage during joining	Theoretical study
B 6.1 Drop test	Drop test from 1m height; No damages or impairments of function	LV215-2 DIN EN 60068-2-31
PG7 HANDING AND FUNCTIONAL RELIABILITY OF THE HOUSINGS		
E 7.1 Error-proof design of housings	Coding/Polarization Test load: 80N	LV214 DIN EN 60512-13-5

E 7.2 Retention force of the housing latch/lock	Retention force of the housing latch mechanism/housing interlock: >350N	LV215-2 DIN EN 60512-15-6
E 7.3 Functionality of CPA	Actuation force to close: 5-30N CPA Efficiency: >80N	DIN EN 60512-15-6
E 7.4 Insertion force or actuation force for insertion with removal aids	Insertion and actuation force: ≤ 75N	DIN EN 60512-15-6
PG 8 MATING AND RETENTION FORCE OF CONTACT PARTS		
E 8.1 Contact insertion forces	Cable assy with CSJ21-Contact: Insertion force ≤50N	LV214
E 8.2 Contact removal force from the housing	TPA lock measured Cable assy with CSJ21-contact ≥ 250N HVIL-contact ≥ 55N	LV214
PG 9 SKEWED INSERTION ANGLE		
E 9.2 Max. possible insertion inclination	Max. possible insertion inclination warrants the contacting without damage	Theoretical study
E 9.3 Examination of housing for scoop-proofing	Live parts must only touch its counter-part while mounting (including insertion chamfers). In case of incorrect insertion of the plug no live parts must be touched	Theoretical study
PG 11 MATING CYCLES		
B 11.1 Mating cycles	Connector with HVIL-Contacts 20 Cycles	LV214
PG 13 HOUSING INFLUENCE ON THE DERATING		
E 13.2 Derating with housing	Dependent on application and cable type different values are possible Max. temperature at contacts 180° C Derating see appendix 5.1	LV215-2 DIN EN 60512-5-1/2
PG 17 DYNAMIC LOAD		
B 17.2 Dynamic Load Broad-band random	Severity 2: "Body" sealed; Details see appendix 5.2 Slight wear, surface ok. Resistances after testing <ul style="list-style-type: none"> ● Contact ≤0.26mΩ(50mm²); ≤0.24mΩ(70mm²) ≤0.22mΩ(95mm²) ● HVIL-Contact ≤15mΩ ● Shielding cable – aggregate <7mΩ 	LV214 DIN EN 60068-2-64
B 17.3 Endurance shock test	30g; T=6ms; N=6000 Slight wear, surface ok. Resistances after testing <ul style="list-style-type: none"> ● Contact ≤0.26mΩ(50mm²) ≤0.24mΩ(70mm²); ≤0.22mΩ(95mm²) 	LV214 DIN EN 60068-2-27

	<ul style="list-style-type: none"> ● HVIL-Contact $\leq 15\text{m}\Omega$ ● Shielding cable – aggregate $< 7\text{m}\Omega$ 	
PG 18A DICING SALT LOAD		
B 18.2 Salt spray, cyclic	Resistances after Salt spray test, not sealed <ul style="list-style-type: none"> ● Contact $\leq 0.26\text{m}\Omega(50\text{mm}^2)$ $\leq 0.24\text{m}\Omega(70\text{mm}^2)$; $\leq 0.22\text{m}\Omega(95\text{mm}^2)$ ● HVIL-Contact $\leq 15\text{m}\Omega$ ● Shielding cable – aggregate $< 7\text{m}\Omega$ 	LV215-2 DIN EN 60068-2-52 (SG3)
PG 20 CLIMATIC LOAD OF HOUSINGS		
B 20.1 Dry heat	Dry heat 120h / 130°C	LV214
B 20.2 Damp heat	Damp heat 10 days / 40°C / 95% rel. humidity Insulation resistance at 1kVDC: $> 200\text{M}\Omega$	LV214
B 20.3 Climatic cold	Climatic cold 48h / -40°C Plugging / unmating possible at -20°C	LV214
B 20.1 Dry heat	Dry heat 48h / 80°C	LV214
B 6.1 Drop test after aging	Drop test from 1m height; No damages or impairments of function	LV215-2 DIN EN 60068-2-31
PG 21 LONG-TERM AGING		
B 21.1 Long-term aging in dry heat	1000h at 130°C; Resistances after aging: <ul style="list-style-type: none"> ● Contact $\leq 0.26\text{m}\Omega(50\text{mm}^2)$ $\leq 0.24\text{m}\Omega(70\text{mm}^2)$; $\leq 0.22\text{m}\Omega(95\text{mm}^2)$ ● HVIL-Contact $\leq 15\text{m}\Omega$ ● Shielding cable – aggregate $< 7\text{m}\Omega$ Functionality; Contact Removal forces acc. E8.2	LV215-2 DIN EN 60068-2-2
PG 22B CHEMICAL RESISTANCE		
B 22.1B Chemical Resistance (water-tight design)	Application of media for 48h at specified temperature; only tested at single parts No textural or dimensional change, no impairments of function Insulation resistance $> 100\text{M}\Omega$	LV214
PG 23 WATER - TIGHTNESS		
B 19.3 Aging in dry heat	120h at 130°C	DIN EN 60068-2-2
B 19.1 Temperature shock	Period: 144 cycles -40°C / +130°C each 15min	DIN EN 60068-2-14
B 23.1 Immersion with pressure difference	Low pressure: -10kPa, holding time 5min. -50kPa, holding time 5min. Change in pressure: 10 kPa/min	LV214 DIN EN 60512-14-5

B 23.2 Immersion with pressure difference	Movement of cable at low pressure: -10kPar, holding time 5min. -50kPabar, holding time 5min.	LV214 DIN EN 60512-14-5
B 23.3 Thermal shock test	30min. in 120°C air; 15min in 0°C Water. 5 cycles	LV214
B 23.4 Degree of protection test / pressure washer test	Severity: IP X9K Test duration per side: 15s Distance to nozzle: 10-15cm Pressure: 80 bar Temperature: 80°C	LV214 DIN 40050-9
E 0.3 Insulation resistance	Insulation resistance at 1000VDC: >200MΩ	LV215-2 DIN EN 60512-3-1
PG 50 EMC – ELECTROMAGNETIC COMPATIBILITY (for shielding version)		
PG 50 EMC- Electromagnetic compatibility	Frequency	Delta-Transfer impedance
	2MHz	<10mΩ
	30MHz	<50mΩ
PG 51 IP PROTECTION OPEN CONNECTOR		
PG51 Protection open connector	IP-Protection IPXXB, un-mated (VDE test finger ø12mm) IP-Protection IPXXD, mated	ISO 20653

3.7 Additional Test Procedures and Test Results 附加的测试方法和结果

Table 7: Additional test requirements

Test Description	Requirement	Procedure
A1 Crimp validation PG1	Pull out force of shield crimp: >150N Cross section examination: crimp sleeves are well formed	TE-Spec. 109-18212
A2 Crimp validation PG2	Shield resistance <3mΩ	TE-Spec. 109-18212
Cable used for crimp validation Xinhongye-No.: TEVBA70-04-310/ 70mm ² shield cable		
A3	UL finger protection	UL2231-2
A4 Retention force further connector parts	Seal cover retention force: >500N Shut bar retention force: >30N Bushing retention force:>50N MQS housing retention force:>60N	TE-Spec. 109-18212
A5 Insertion force further connector parts	TPA 2 nd lock insertion force: 15<F<55N TPA + Retainer(For unshield) 2 nd lock insertion force: 30<F<80N MQS housing insertion force: F<60N	TE-Spec. 109-18212

3.8 Test sequence 试验顺序

Table 8: Test sequence

Test or Examination	Test group and sequence												
	1	2	3	4	5	6	7	8	9	10	11	12	13
visual examination	1	1	1	1,3	1,4	1,4	1,5	1	1	1,9	1,5	1	1,4,7,9,12
Contact resistance	2						2,4		2,4		2,4		
Isolation Resistance	3									2,5		2,4	11
Dielectric withstand	4												
crimp cross examination	5												
Temperature Raising		2											
EMC			2										
Drop test				2						8			
Retention force of the housing latch/lock (unequipped housing)					2								
Insertion force or actuation force for insertion and removal aids					3								
Contact insertion force						2							
Contact removal force						3							
Mating cycles							3						
Analysis of contact surfaces							6						
IP-protection: IPXXB								2					
UL-protection: UL2231								3					
Salt spray, cyclic SG2									3				
Dry heat(120h / 130°C)										3			2
Damp heat(10 days / 40°C / 95% rel. humidity)										4			
Climatic cold(48h / -40°C Plugging / unmating at -20°C)										6			
Dry heat(48h / 80°C)										7			
Long-term aging in dry heat(1000H at 130°C)											3		
Chemical Resistance												3	
Thermal shock(-40°C/130°C 15min. Respectively, 144 cycles)													3
Immersion with pressure difference													5
Line movement during immersion with pressure difference-vacuum													6
Thermal shock test(5% NaCl, 120°C/30min,0°C/15 min),5 cycles													8
Degree of protection test/pressure washer test(IPX9K)													10

Test or Examination	Test group and sequence	
	14	15
visual examination	1,6	1,7
Contact resistance	2,5	2,6
Dynamic load, broad-band random vibration (LV215)	3	
Endurance shock test	4	5
Dynamic load, broad-band random vibration (ISO)		3
Dynamic load, broad-band Sine vibration (ISO)		4

4. QUALITY 质量

4.1 Qualification test 鉴定

Samples must be in accordance with drawings and be taken in a random way in the production in progress.

样件必须与产品图纸一致，并且是生产过程中随机选取的。

4.2 Requalification test 重新鉴定

If changes significantly affecting form, fit, or function are made to the product or to the manufacturing process, product assurance shall coordinate requalification testing, consisting of all or part of the original testing sequence as determined by product engineering.

如果产品或者制造过程中有显著影响外观，装配和功能的设变，质保需要协调按照原先工程部定义的测试顺序，重新验证全部或者部分测试项目。

4.3 Acceptance 验收

Acceptance is based on verification that the product meets the requirements of section 3.6. Failures attributed to equipment, test setup, or operator deficiencies shall not disqualify the product. When product failure occurs, corrective action shall be taken and samples resubmitted for qualification. Testing to confirm corrective action is required before resubmitted.

归咎于测试设备，样件安装或者操作员的失误的失效不应判定产品不合格。当产品失效发生时，需要有纠正措施以及重新提交样件进行验证。在重新验证前，需确认已有纠正措施。

4.4 Quality conformance inspection 质量合格检验

The applicable TE Connectivity quality inspection plan will specify the sampling acceptable quality level to be used. Dimensional and functional requirements shall be in accordance with the applicable product drawing and this specification

TE Connectivity 的质量检验计划将指定适用的质量标准。尺寸和功能要求，应按照适用的产品图纸和本规范。

5. APPENDIX 附件

5.1 Derating inside housing 成品温升降额曲线

Derating inside housing: Current at contact

Force shield cable, cable length 1m

80% Characteristic curve of measured value

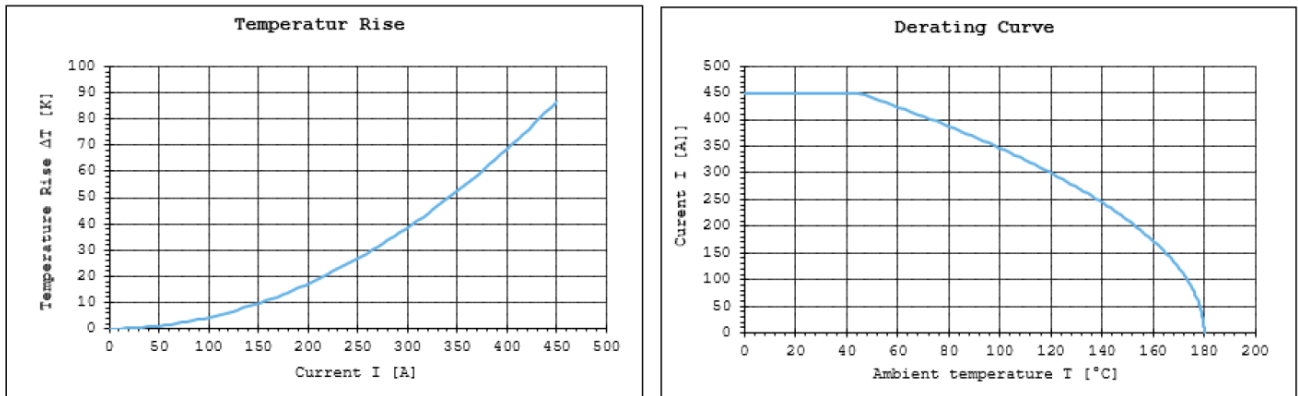

Derating inside housing: Current at contact

Force 95mm² Al unshield cable, cable length 1.4m

80% Characteristic curve of measured value

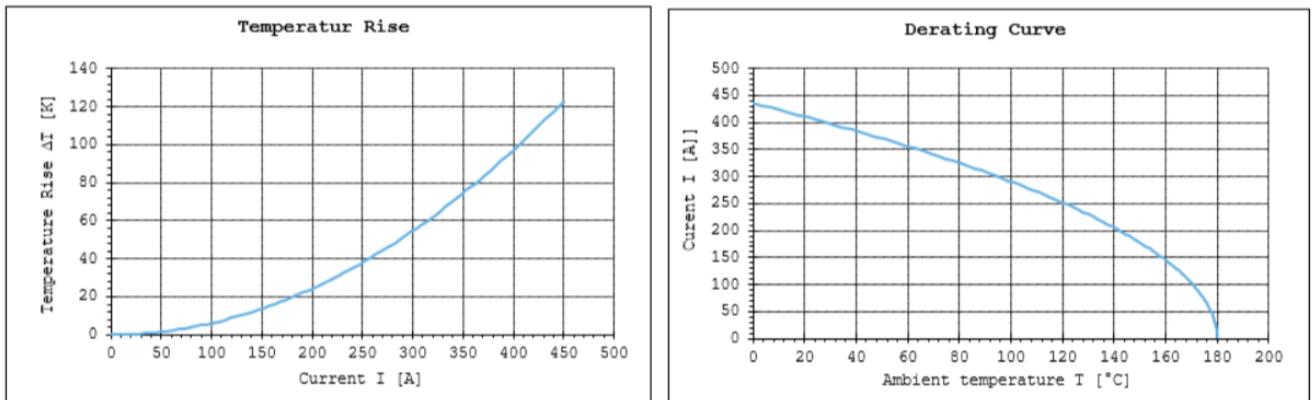

Figure 4: Derating and temperature rise – 95mm² Al unshield cable

Derating inside housing: Current at contact

Force 95mm² Cu unshield cable, cable length 1.4m

80% Characteristic curve of measured value

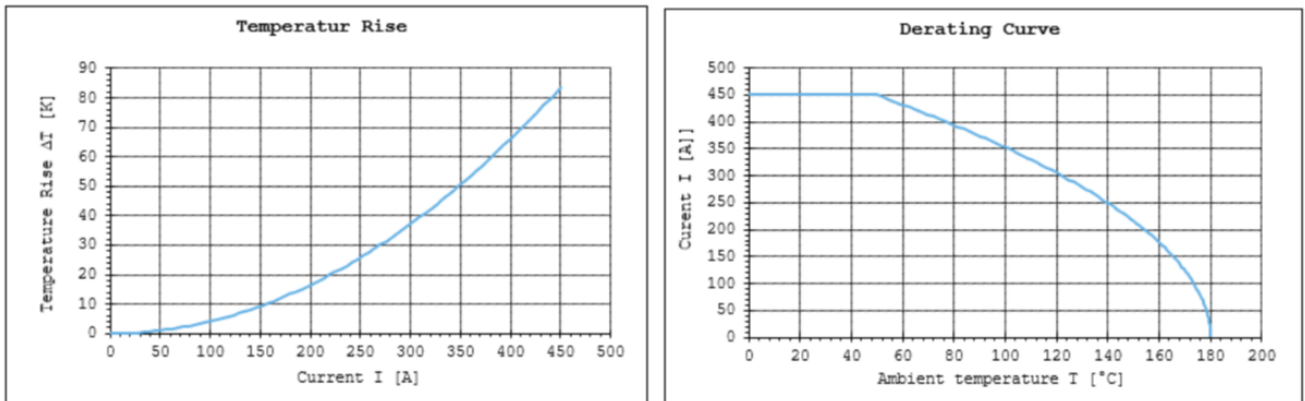

Figure 5: Derating and temperature rise – 95mm² Cu unshield cable

5.2 Dynamic load (LV215 S2) 震动性能(LV215 S2)

Dynamic load acc. LV215 (released 2017-09)

Design of vibration device (see picture 2)

shield cable, cable length 500mm

Cable fixed after dimensioning A=200mm, B=250mm



Figure 3: Vibration device (exemplary view)

Dynamic load acc. VW 80332(Released 2021-02)

Design of vibration device (see picture 2)

unshield cable, cable length 500mm

Cable fixed after dimensioning A=100mm, B=250mm

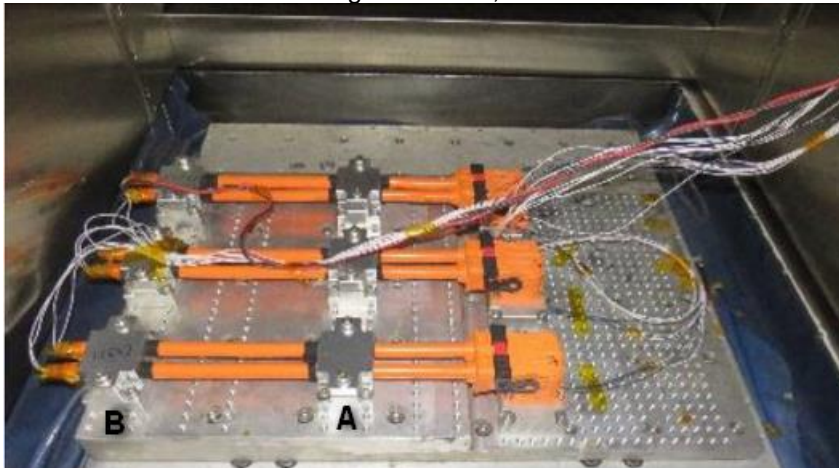

Picture 3: Vibration device (exemplary view)

5.3 Contact engagement length 端子接触长度

- | | | | |
|---|----------------------------------|--------|-------------------|
| A | Contact overlap – Power contact | 电源端子 | $\geq 1\text{mm}$ |
| B | Contact overlap – HVIL contact | 高压互锁端子 | $\geq 1\text{mm}$ |
| C | Contact overlap – Shield contact | 屏蔽接触 | $\geq 1\text{mm}$ |

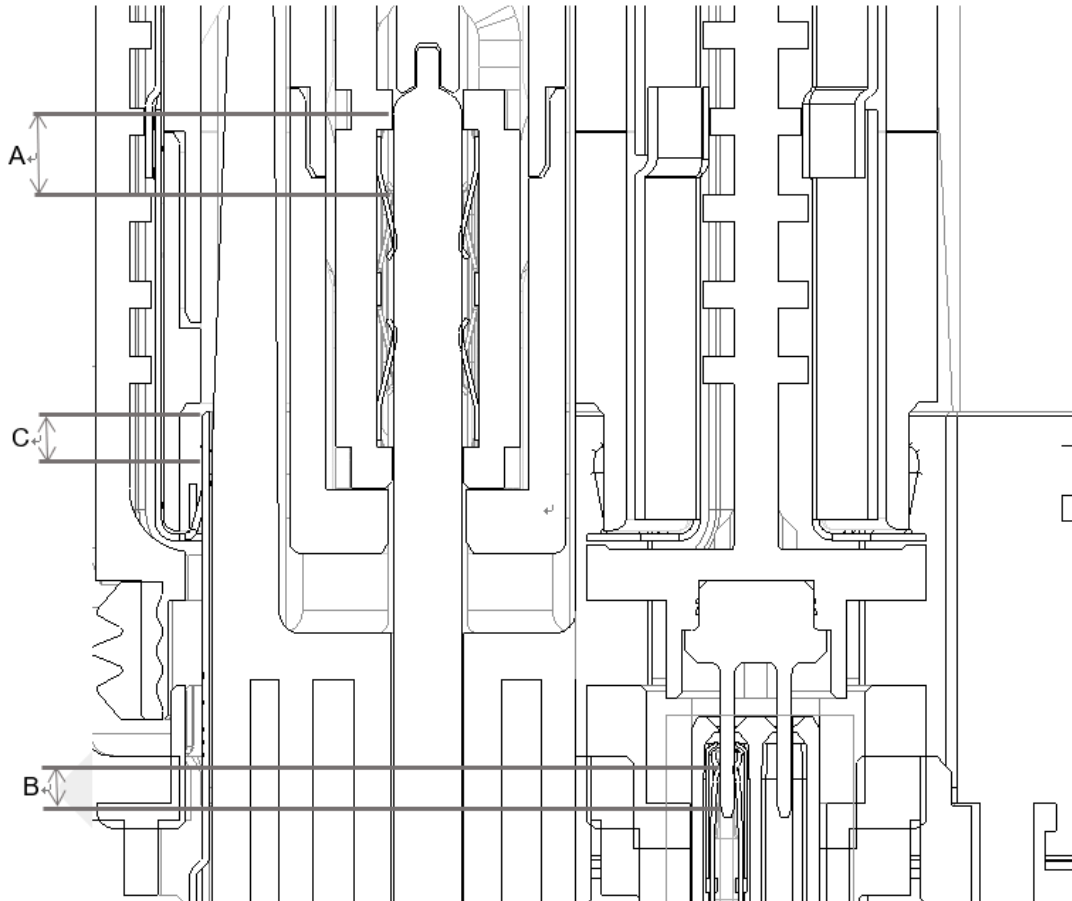

5.4 Strain Relief 应力释放

System is validated with strain relief at 100mm. Each application has to be evaluated independently with regards to the external influences on the system. Having strain relief, which moves with the connector body, close to the end of the connector will have a positive influence on the performance of the connector. Have strain relief further from the end of the connector or that moves independent of the connector body will have a negative influence on the performance of the connectors.

系统通过 100mm 的应变消除进行验证。每个应用都必须独立评估对系统的外部影响。随连接器主体移动的压力释放，接近连接器的末端将对连接器的性能产生积极影响。应变释放离连接器的末端更远或者连接器主体晃动将对连接器的性能产生负面影响。

