

1. SCOPE

1.1. Content

This specification covers performance, tests, and quality requirements for the FASTON* connector cap housing as shown in Figure 1.

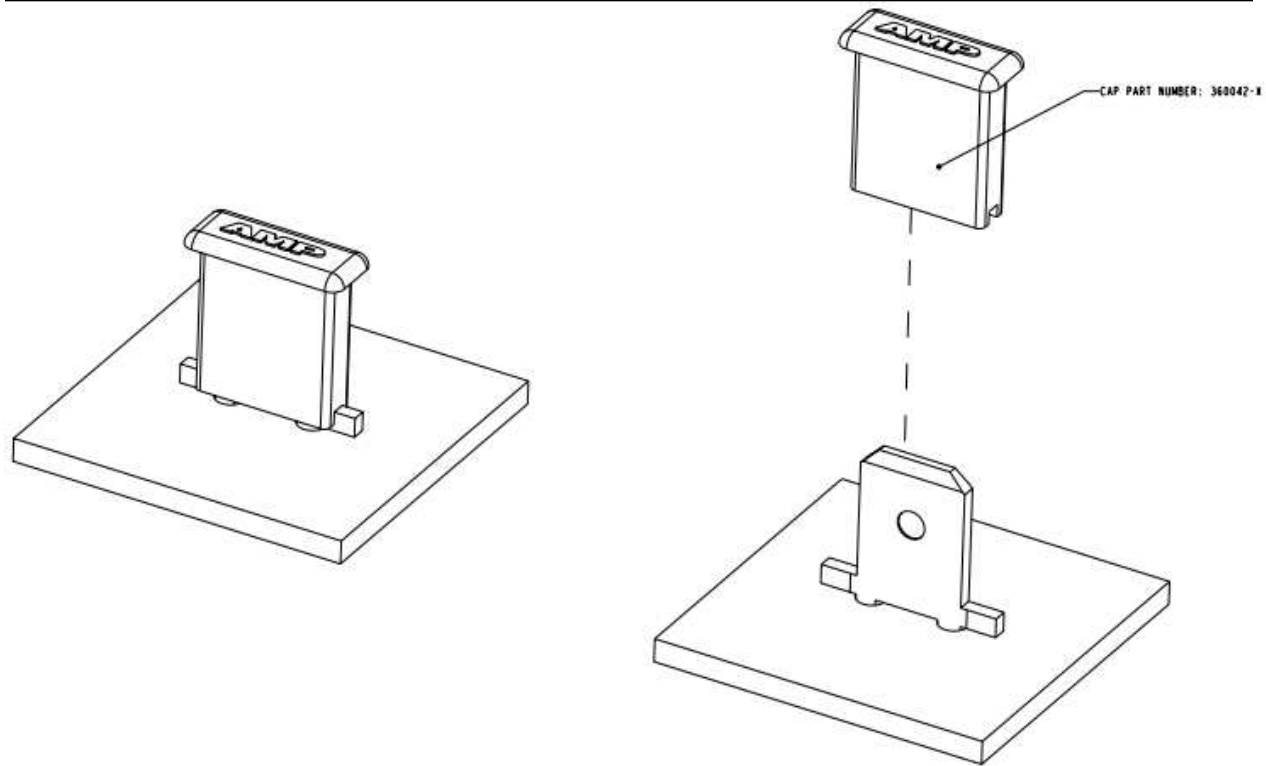

Figure 1

1.2. Qualification

When tests are performed on the subject product line, procedures specified in Figure 2 shall be used. All inspections shall be performed using the applicable inspection plan and product drawing.

1.3. Qualification Test Results

Successful qualification testing on the subject product line has been completed.

1.4. Revision Summary

Revisions to this specification include:

- Initial release of specification.
- Harmonized sample quantity with UL 1977 requirements.
- Updated housing voltage rating requirements for Dielectric Withstanding Voltage to reflect UL 1977 requirements and considering end application requirements.

2. APPLICABLE DOCUMENTS AND FORMS

The following documents form a part of this specification to the extent specified herein. Unless otherwise specified, the latest edition of the document applies. In the event of conflict between the requirements of

this specification and the product drawing, the product drawing shall take precedence. In the event of conflict between the requirements of this specification and the referenced documents, this specification shall take precedence.

2.1. TE Connectivity Specifications

114-2115 FASTON* 110, 187, 205, 250, and 312 Series Tab Contacts for Printed Circuit (PC) Board Applications

2.2. Commercial Standards and Specifications

EIA-364 Electrical Connector/Socket Test Procedures Including Environmental Classifications

UL 1977 UL Safety Standard for Component Connectors for Use in Data, Signal, Control, and Power Applications

2.3. Reference Documents

109-1 General Requirements for Testing

102-950 Qualification of Separable Interface Connectors

501-160750 T9A Relay RH Housing Qualification Test Report

501-134141 T9A Relay LH Housing Qualification Test Report

502-143197 T9G Relay Housing Qualification Test Report

3. REQUIREMENTS

3.1. Design and Construction

Product shall be of the design, construction, materials and physical dimensions specified on the applicable product drawing.

3.2. Materials

Materials used in the construction of this product shall be as specified on the applicable TE drawing.

3.3. Ratings

A. Voltage Rating: Can be determined using Table 17.1 from UL 1977. Commonly considered voltage ratings include 250, 300, or 600 VAC. Dependent upon spacings and materials selected

B. Current Rating: N/A (Contact and wire size determines current rating.)

C. Temperature Rating: -40°C to housing temperature rating (RTI Electrical Value) per product drawing

3.4. Performance Requirements and Test Description

The product should meet the electrical, mechanical and environmental performance requirements specified in Figure 2. All tests shall be performed at ambient environmental conditions otherwise specified.

3.5. Test Requirements and Procedure Summary

Test Description	Requirement	Procedure
Examination of Product	Meet requirements of product drawing. After testing, there shall be no corrosive influence on the performance and no physical damage.	EIA-364-18 Visual and dimensional (C of C) inspection per the product drawing.

Electrical		
Dielectric Withstanding Voltage	1 minute hold without a creep discharge or flashover. Current leakage: 5 mA maximum (Housing fully loaded with applicable terminal terminated to largest wire size [UL 1015 wire] defined for terminal.)	V _{AC} : 3400 V _{AC} Hold at specified voltage for 1 minute. Reference: EIA-364-20, Method A, Condition I for any undefined aspects of test setup See Figure 3 for test setup
Mechanical		
Contact Insertion Force into Housing	6 # max [26.69 N.]	EIA-364-05 Operation Speed: 25.4 mm/min Measure the force required to insert contact into housing.
Contact Retention Force in Housing	Series	EIA-364-29, Method C Operation Speed: 25.4 mm/min Measure the maximum force required to dislodge the contact from the housing
	250	
	Load (minimum)	
	1.0 # [4.45 N.]	
Environmental		
Mold Stress	No warpage, shrinkage, degradation, or cracks.	UL 1977 RTI Electrical + 10°C for 7 hours.

Figure 2 (end)



NOTE

Shall meet visual requirements, show no physical damage, and meet requirements of additional tests as specified in the Product Qualification and Requalification Test Sequence shown in Figure 3.

3.6. Product Qualification and Requalification Test Sequence

TEST OR EXAMINATION	TEST GROUP (a)		
	1 Housing Electricals	2 Contact Retention	3 Mold Stress
	TEST SEQUENCE (b)		
Examination of Product	1, 4	1, 4	1, 4
Insulation Resistance	2		
Dielectric Withstanding Voltage	3		3
Contact Insertion Force into Housing		2	
Contact Retention Force in Housing		3	
Glow Wire			
Mold Stress			2
Minimum Number of Samples	(6)	(30)	(6)

Figure 3



NOTE

- (a) See paragraph 4.2.
- (b) Numbers indicate sequence in which tests are performed.
- (c) Only on parts with glow wire material.

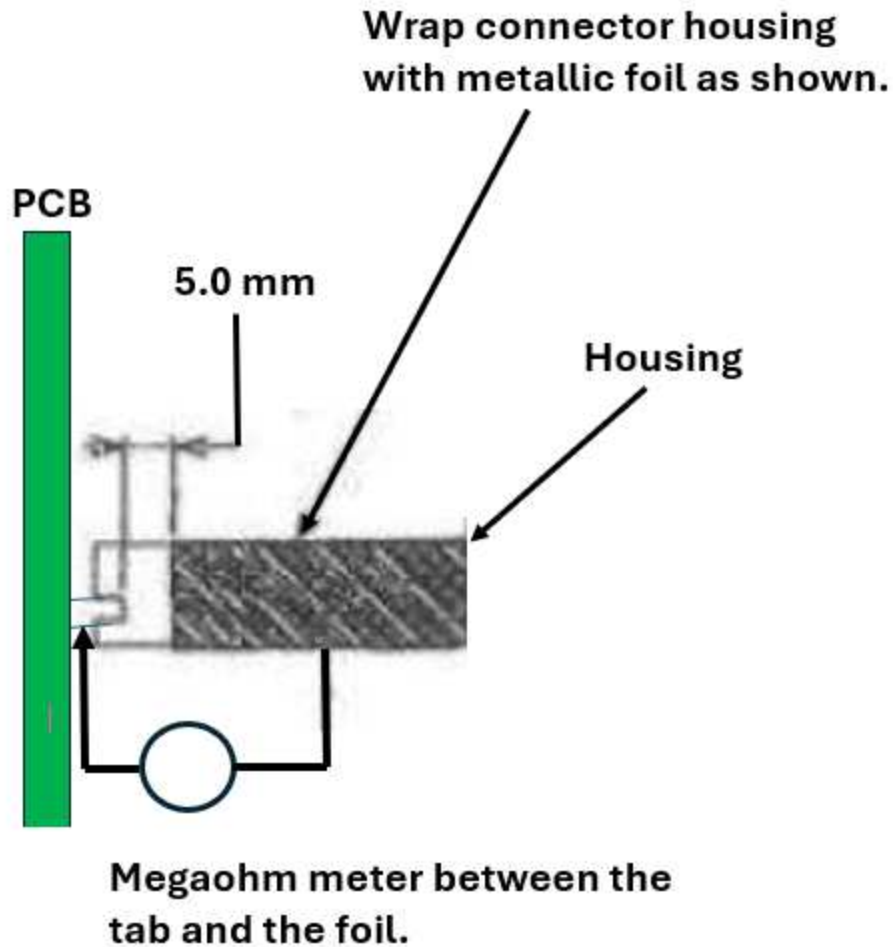

Figure 4

4. QUALITY ASSURANCE PROVISIONS

4.1. Test Conditions

Unless otherwise specified, all the tests shall be performed in any combination of the following test conditions shown in Figure 5.

Temperature	15°C – 35°C
Relative Humidity	45% – 75%
Atmospheric Pressure	86.6 – 106.6 kPa

Figure 5

4.2. Qualification Testing

A. Specimen Selection

Specimens shall be prepared in accordance with applicable instruction sheets and shall be selected at random from current production.

B. Test Sequence

Qualification inspection shall be verified by testing specimens as specified in Figure 3.

4.3. Requalification Testing

If changes significantly affecting form, fit or function are made to the product or manufacturing process, product assurance shall coordinate requalification testing, consisting of all or part of the original testing sequence as determined by development/product, quality and reliability engineering.

4.4. Acceptance

Acceptance is based on verification that the product meets the requirements in Figure 2. Failures attributed to equipment, test setup or operator deficiencies shall not disqualify the product. If product failure occurs, corrective action shall be taken and specimens resubmitted for qualification. Testing to confirm corrective action is required before resubmittal.

4.5. Quality Conformance Inspection

The applicable quality inspection plan shall specify the sampling acceptable quality level to be used. Dimensional and functional requirements shall be in accordance with the applicable product drawing and this specification.