

Z-Pack* 2 mm HM CONNECTORS

1. SCOPE .

1.1 Content:

This specification covers the performance, test and quality requirements for the Z-PACK* 2mm HM connector system.

These connectors are two-piece devices to interconnect 2 printed circuit boards. Receptacle connectors and pin connectors are through hole devices with ACTION PIN* contacts.

Connectors are in 5 configurations and can be upgraded to 7 row configurations.

1.2 Qualification:

When tests are performed on the subject product line, the procedures specified in IEC 60512 shall be used unless otherwise indicated.

All inspections shall be performed using the applicable inspection plan and product drawing.

2. APPLICABLE DOCUMENTS:

2.1 Tyco Electronics Documents:

114-19029	Application specification
R 041-1566	Test Report

2.2 Drawings**

C-100143	C-100141
C-100159	C-100147
C-100145	C-100161

** The list of drawings is not exhaustive. Other specific numbers may exist due to customer specific sequencing patterns.

2.3 Other Documents:

IEC 60512	Test Specification
-----------	--------------------

*Z-PACK and ACTION PIN are trademarks

3. REQUIREMENTS:**3.1 Design and construction:**

Product shall be of design, construction and physical dimensions specified in the applicable product drawing.

3.2 Materials:

Contacts:	CuSn 4 (Phosphor Bronze), plating in contact area: 1) Gold over nickel or... 2) Palladium nickel + gold flash over nickel or... 3) Other Engineering approved alternative.
Housings:	Thermoplastic polyester GF PBT or GF PBT/PC Blend color grey UL 94V0
Coding devices:	Polyamide 35% GF, various colors, UL 94 HB

3.3 Ratings and characteristics:

Rated Voltage:	500 V r.m.s. contact to contact
Current rating:	1,5A / contact at 70°C (fully loaded)
Voltage proof	750 V r.m.s. contact to contact
Temperature:	-55°C through 125°C
Insulation resistance:	10 ⁴ MΩ min.
Contact resistance:	20 mΩ max.
Mech. operations:	250 matings / unmatings
Air/creepage distance:	0,8 mm min.

3.4 Printed wiring boards:

Plated holes 0,6 ± 0,05 mm.
1,4 - 5,6 mm thick (backplanes)
1,4 - 4,2 mm thick (daughtercards)

3.5 Performance and test description:

The product is designed to meet electrical, mechanical and environmental performance specified in figure 1 as tested per the test sequence in figure 2.

All tests are performed at ambient environmental conditions per IEC specification 60512-1 unless otherwise specified.

Test Description	Severity and/or condition	IEC Test 60512-nr	Requirement
1. General Examination:			
1.1. Visual examination	- Unmated	2-1a	No defects that would impair normal operation.
1.2. Examination of dimensions	- Unmated	2-1b	Dimensions to comply with product drawing.
2. Electrical:			
2.1. Contact resistance	Millivolt level method Mated see figure 3	2-2a	20 mΩ max. initial, 5 mΩ max. increase final
2.2. Voltage proof	Test voltage 750 VAC r.m.s. Mated see figure 4	2-4a method B	No breakdown or flashover
2.3. Insulation resistance	Test voltage 100 V d.c. Mated	2-3a method A	10 ⁴ MΩ min. initial, 10 ³ MΩ min. final
2.4. Electrical load and temperature	1,5A at 70°C 1000 h All contacts loaded	5-9b	Max. temperature 125°C
2.5. Contact disturbance	- Mated, 6 contacts/connector	2-2e	Max. disturbance 1 microsecond
3. Mechanical			
3.1. Vibration sinusoidal	10-500Hz, Amplitude 0,35 mm or a= 50 m/s ² Mated 10 sweepings in each direction see figure 5	4-6d	Contact disturbance see 2.5
3.2. Physical	Acceleration 490 m/s ² duration of impact 11 ms 5 shocks in 2 directions in 3 axis see figure 5	4-6c	Contact disturbance see 2.5
3.3. Gauge retention force	15g gauge dimensions see figure 6	8-16e	Gauge shall be retained
3.4. Engagement / separation force	Speed 10 mm/s. max. rest min. 30 s. Unmated	7-13a	Engagement max 0,75N / contact Separation min. 0,15N / contact
3.5. Contact retention in insert	- Unmated	8-15a	Mating direction 5N, unmating direction 10N (male) 5N (female) axial displacement max. 0,1 mm

Figure 1

Test Description	Severity and/or condition	IEC Test	Requirement
3. Mechanical (cont'd)			
3.6. Mechanical operations	125 cycles (total number of operations 2x125)	5-9a	
3.7. Retention force of press-in connections	-	-	13.5N / press-in connection
3.8. Polarisation force	100N (50 mm modules) 50N (25 mm modules)	7-13e	No damage that would impair normal operation It shall be impossible to mate the connectors in any
3.9. Static load, traverse 50 mm module 25mm module F1 = 100N F2 = 75N F3 = 50N	Unmated see fig 7	5-8a	No displacement of the connector on the pc board likely to impair normal operation.
4. Environmental :			
4.1. Rapid change of temperature	-55°C / +125°C 5 cycles 30 min. / temp	6-11d	
4.2. Dry heat	125°C 16h	6-11i	
4.3. Damp heat cycle	40°C upper temperature	6-11m	
4.4. Cold	-55°C 2h	6-11j	
4.5. Damp heat steady state	21 days 40°C 93% RH		
4.6. Corrosion industrial atmosphere	4 days 500 ± 100 mm ³ / m ³ SO ₂ 100 ± 20 mm ³ / m ³ H ₂ S	IEC 60068-2-60 (Kc)	

Figure 1 (cont'd)

3.6 Product Qualification and Requalification (cont'd).

Test or examination Test group 4

Damp heat steady state	4.5.
Insulation resistance	2.3.
Contact resistance, final	2.1.
Voltage proof	2.2.
Engagement / separation force	3.4.
Visual examination	1.1.

Test or examination Test group 5

Mechanical operations	3.6.
Electrical load and temperature	2.4
Contact resistance, final	2.1.
Insulation resistance	2.3.
Voltage proof	2.2.
Visual examination	1.1.

Test or examination Test group 6

Retention force of press-in connectors	3.7.
Visual examination	1.1.

Figure 2 (cont'd)

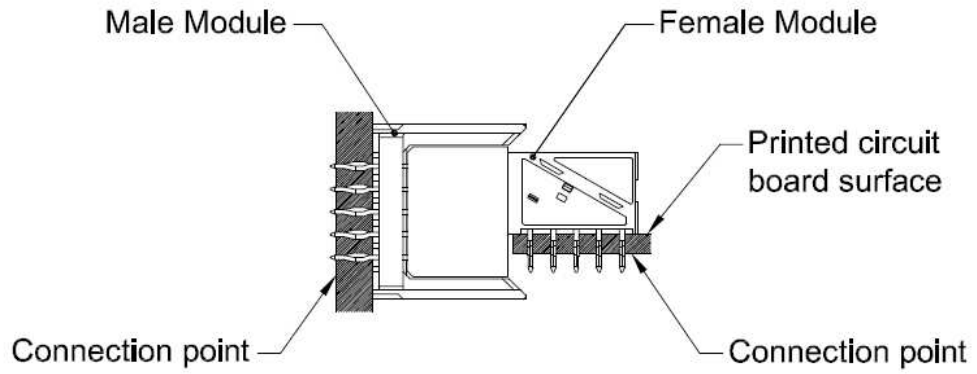

Figure 3: Points of connection for contact resistance measurement.

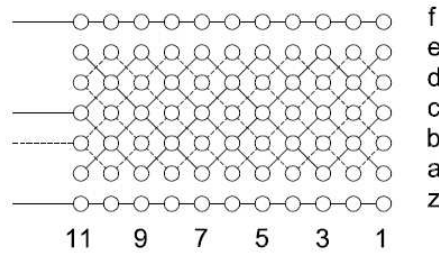

Figure 4: Wiring arrangement for voltage proof.

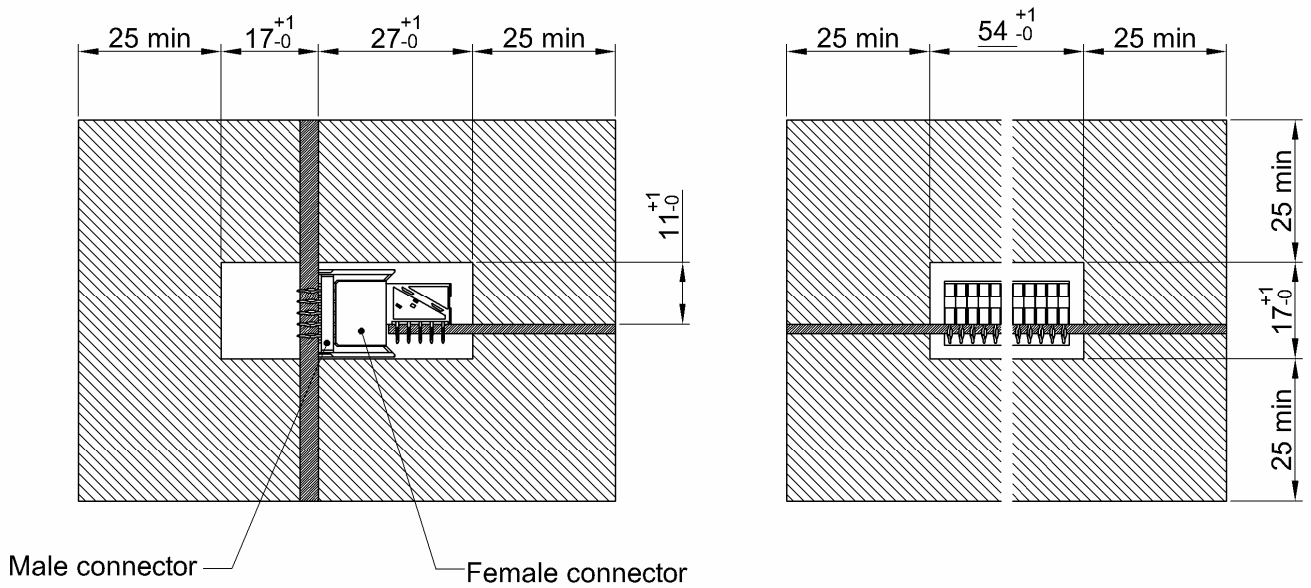
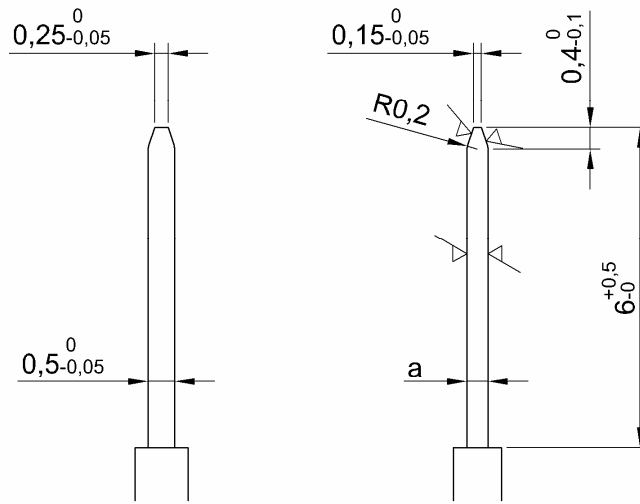

Figure 5: Fixture for dynamic stress tests.



longitudinal direction

transversal direction

Application	a	Mass
Sizing	0,40 to 0,39	-
Retention force	0,36 to 0,35	16g to 15g

Figure 6: Sizing and retention force gauge for female contacts.

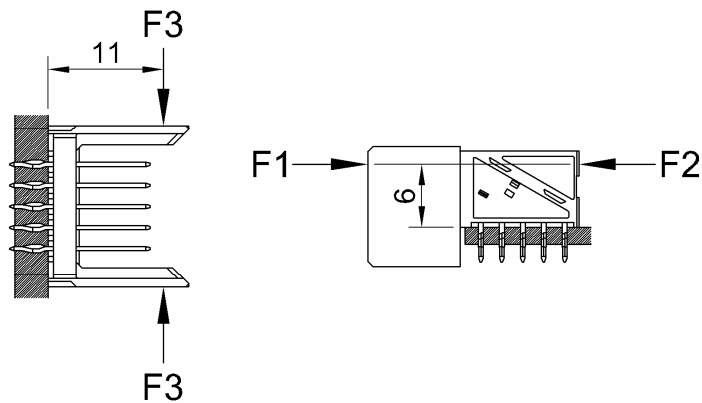

Figure 7: Test arrangement and application forces for static load test.

4. **QUALITY ASSURANCE PROVISIONS:**

4.1 **Qualification testing:**

a. Sample selection:

Connector housings and contacts shall be prepared in accordance with applicable Instruction Sheets. They shall be selected at random from current production.

Test group 1 shall consist of all connectors used for test groups 2, 3, 4, 5 and 6.

Test groups 2, 3, 4 and 5 shall consist of 4 male and 4 female connector modules (110 pos.)

Test group 6 shall consist of 2 male and 2 female connector modules (110 pos.)

b. Test sequence:

Qualification inspection shall be verified by testing samples as specified in figure 2

4.2 **Requalification Testing:**

If changes significantly affecting form, fit or function are made to the product or to the manufacturing process, product assurance shall coordinate requalification testing, consisting of all or part of the original testing sequence as determined by development/product, quality and reliability engineering.

4.3 **Acceptance:**

Acceptance is based on verification that the product meets the requirements of figure 1.

Failures attributed to equipment, test set-up, or operator deficiencies shall not disqualify the product. When product failure occurs, corrective action shall be taken and samples resubmitted for qualification. Testing to confirm corrective action is required before resubmittal.

4.4 **Quality Conformance Inspection:**

The applicable Tyco Quality Inspection Plan (Q.I.P.) will specify the sampling acceptable quality level to be used.

Dimensional and functional requirements shall be in accordance with the applicable product drawing and this specification.