

## Z-PACK Slim UHD Connector System (performance level 1)

### 1. SCOPE

#### 1.1 Content

This specification covers performance, test and quality requirements for TE Z-PACK Slim UHD Connector System. This connector system interconnect two printed circuit boards. Male as well as Female connectors are connected to the printed circuit board with plated thru-hole compliant press-fit leads. Z-PACK Slim UHD Connector Systems include Common Speed as well as High Speed Connectors.

#### 1.2 Qualification

Telcordia's GR-1217-CORE, Section 7; New Technology Prequalification and Reliability Verification test program is used with the following four key Environmental Stress Tests and based on Uncontrolled Environment (QL III) applications:

- Temperature Life Test
- Temperature Cycling with Humidity Test
- Vibration and Shock Test
- The Four-Gas Mixed Flowing Gas (MFG) Corrosion Test.

When tests are performed on subject product, procedures specified in this specification shall be used. All inspections shall be performed using applicable inspection plan and product drawing.

### 2. APPLICABLE DOCUMENTS

The following documents form a part of this specification to the extent specified herein. Unless otherwise specified, the latest edition of the document applies. In the event of conflict between the requirements in this specification and the product drawing, the product drawing shall take precedence. In the event of conflict between requirements of this specification and the referenced documents, this specification shall take precedence.

#### 2.1 Tyco Electronics Documents

114-19106	Application Specification
501-60071	Qualification Test Report
109-197	AMP Test Specifications vs. EIA and IEC Test Methods

DR. Fred Liu

DATE 23Nov2015

APVD Frank Yang

DATE 23Nov2015

## 2.2 Other Documents

GR-1217-CORE	Telcordia Generic Requirements for Separable Electrical Connectors Used in Telecommunications Hardware.
IEC 60512	Basic testing procedures and measuring methods for electromechanical components for electronic equipment.
EIA-364	Electrical Connector/Socket Test Procedures Including Environmental Classifications
IEC 60068	Basic environmental testing procedures

## 3. REQUIREMENTS

### 3.1 Design and Construction

Products shall be of design, construction and physical dimensions as specified on the applicable product drawing.

### 3.2 Materials and Finish

Materials used in the construction of this product shall be as specified on the applicable product drawing.

### 3.3 Ratings

A.	Working Voltage:	30 Vdc max
B.	Current carrying capacity:	0.5 A per contact (fully loaded)
C.	Operating Temperature:	-55 °C to 105 °C
D.	Durability:	200 cycles

### 3.4 Performance and Test Description

The product is designed to meet electrical, mechanical and environmental performance specified in this paragraph as tested per test sequence specified in Paragraph 3.6.

Unless otherwise specified, all tests are performed at ambient environmental conditions and are performed with connectors in fully mated condition.

V I S U A L			
Para	Test Description	Requirements	Procedure / Severity
3.4.1	Visual examination	Initial: Meets requirements of product drawing and applicable instructions on customer drawing and application specification. Final: No functional physical changes.	IEC 60512-1-1 Visual, dimensional and functional per applicable inspection plan. Magnification 10x
E L E C T R I C A L			
Para	Test Description	Requirements	Procedure / Severity
3.4.2	Termination resistance (LLCR)	80 mΩ max. (Initial) ΔR 10 mΩ max. (Final individual) ΔR 5 mΩ max. (Final average)	IEC 60512-2-1 Max. open voltage 20mV. Max. current 100 mA DC. All contacts to be measured. Measuring points shall be as indicated in figure 1. (see also para 3.5.1)
3.4.3	Insulation resistance	10.000 MΩ min.	IEC 60512-3-1 Test voltage 100V DC or AC peak. Duration: 1 minute. Measure between adjacent contacts.
3.4.4	Voltage proof	No break-down or flash-over.	IEC 60512-4-1 Test voltage: 500 VAC. Duration 1 minute. Test between adjacent contacts.

(continued)

<b>M E C H A N I C A L</b>			
<b>Para</b>	<b>Test Description</b>	<b>Requirements</b>	<b>Procedure / Severity</b>
3.4.5	Mating force	n x 0.45 N max. (n = number of positions)	IEC 60512-7-13b Measure force to mate connector pair. Connectors shall align. Speed: 12.7 mm/min.
3.4.6	Unmating force	n x 0.1 N max. (n = number of positions)	IEC 60512-7-13b Measure force to un-mate connector pair. Connectors shall align. Speed: 12.7 mm/min.
3.4.7	Mechanical operation (Durability)	<ul style="list-style-type: none"> <li>No functional damage</li> </ul>	IEC 60512-9-1 Mate and unmate connector pair. Connectors shall align. Operation cycles: 200. Rate: 500 cycles/hour.
3.4.8	Vibration sinusoidal	<ul style="list-style-type: none"> <li>No physical damage</li> <li>No discontinuity &gt; 1 μs</li> </ul>	EIA-364-28E Condition II: 10-500 Hz sinusoidal. Amplitude: 1,52 mm max or acceleration: 98,1 m/s <sup>2</sup> max (10g) Duration: 2 hours on each of 3 mutually perpendicular axes, total of 8 hrs.
3.4.9	Shock	<ul style="list-style-type: none"> <li>No physical damage</li> <li>No discontinuity &gt; 1 μs</li> </ul>	EIA-364-27B Condition H Pulse shape: half sine. Peak acceleration: 294 m/s <sup>2</sup> (30g). Duration of pulse: 11 ms. Apply 3 shocks in each direction of 3 mutual perpendicular axes, total of 18 shocks.

(continued)

ENVIRONMENTAL			
Para	Test Description	Requirements	Procedure / Severity
3.4.10	Temperature life	No physical damage. $\Delta R$ 10 m $\Omega$ max.	EIA-364-17B Method A Test condition 4 Subject mated specimens to 105°C for 1000 hours. (without electrical load)
3.4.11	Dust	No physical damage. $\Delta R$ 10 m $\Omega$ max.	EIA-364-91A Dust Composition Number 1 (Benign)
3.4.12	Thermal shock	No physical damage. $\Delta R$ 10 m $\Omega$ max.	EIA-364-32E Condition II, -65°C to +105°C Number of cycles: 5cycles
3.4.13	Humidity / Temperature cycling	No physical damage. $\Delta R$ 10 m $\Omega$ max.	EIA-364-31C Method III, +5°C to +85°C Number of cycles: 50 10 hrs = 1 cycle Total exposure time: 500 hrs, RH 90 - 98% Transition time: 2 hrs Recovery: 2 hours at 25°C, RH 90 - 98%
3.4.14	Mixed flowing gas	Termination resistance acc para 3.4.2.	EIA-364-65 Class IIIA Gas mixture: NO <sub>2</sub> 0.200 ppm Cl <sub>2</sub> 0.020 ppm H <sub>2</sub> S 0.100 ppm SO <sub>2</sub> 0.200 ppm RH 70 $\pm$ 2% Temperature 30 $\pm$ 1°C Duration: 20 days (first 10 days unmated, remaining 10 days mated) Measure contact resistance after 10 and 20 days of exposure

**3.5 Additional Test and Measuring Details**

**3.5.1 Contact resistance**

Contact resistance shall be measured as indicated in figure 1.  
 Contact path bulk of connected parts is not included in the requirement.

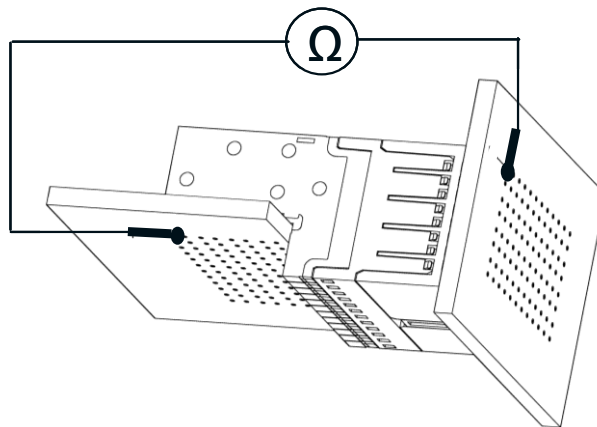
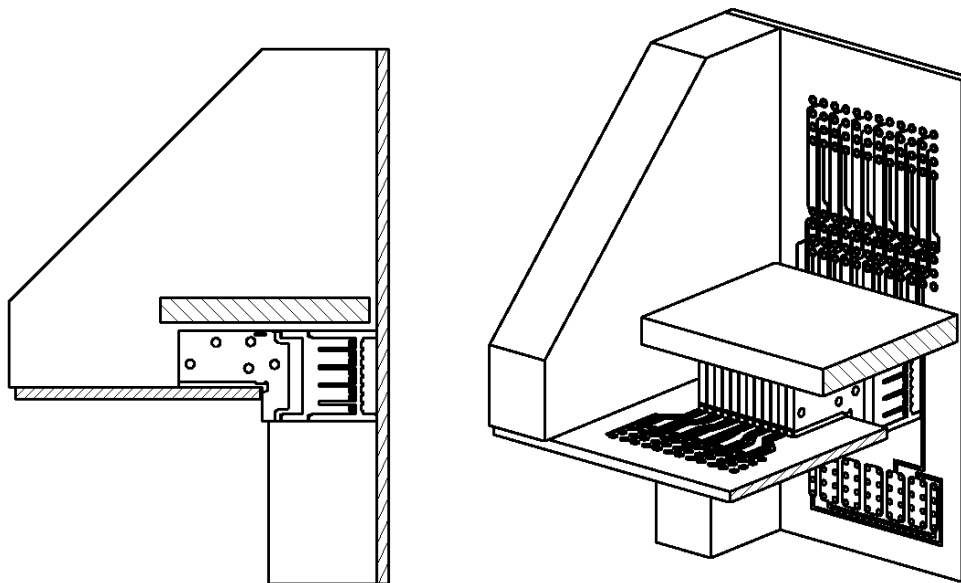

**Figure 1. Contact resistance measurement.**

**3.5.2 Test frames**

Test-frames shall provide mechanical stability of the connector in relation to its mating part and shall cover the requirements specified in the Tyco Electronics application specification.

During Vibration, an electrical circuit is checking that no electrical contact interruptions occur that exceed the requirement.



**Figure 2. Vibration and Physical shock mounting feature example (right angle application shown)**

**3.6 Product Qualification and Requalification Test Sequence**

Test or Examination	Test Group			
	1	2	3	4
	Test Sequence (a)			
Visual Examination	1,16	1,17	1,11	1,15
Termination resistance (LLCR)	5,7,9,12	5,7,9,11,13	5,7	4,7,10,12,14
Insulation Resistance	3,14	3,14	3,9	2
Voltage proof	4,15	4,15	4,10	3,8
Mating and Unmating Forces	2,13	2,16	2,8	6
Vibration	10			
Shock	11			
Durability	6 <sup>(c)</sup>	6 <sup>(c)</sup>		5 <sup>(c)</sup> ,13 <sup>(d)</sup>
Thermal shock		10		
Temperature Life			6	
Dust	8	8		
Humidity / Temperature cycling		12		
Mixed flowing gas (MFG)				9,11 <sup>(b)</sup>

**NOTE:**

- (a) Numbers indicate sequence in which tests are performed.
- (b) = First 10 days unmated, remaining 10 days mated.
- (c) = 100 cycles pre-wear
- (d) = 100 remaining cycles

Connector-pair description	Number of test sample pairs in test groups			
	1	2	3	4
Vert. Male + RA Female HS	3	3	3	3
Vert. Male + RA Female CS	3	3	3	3
RA Male + RA Female HS	3	3	3	3
RA Male + RA Female CS	3	3	3	3

Abbreviations: Vert = Vertical, RA = Right Angle, HS = High Speed , CS = Common Speed

#### 4. **QUALITY ASSURANCE PROVISIONS**

##### 4.1 **Qualification testing**

###### A. Sample selection

Samples shall be prepared in accordance with applicable instructions and shall be selected at random from current production.

Unless otherwise specified, all test-groups shall consist of a minimum of 3 connectors of which all contacts shall be tested.

###### B. Test sequence

Qualification inspection shall be verified by testing samples as specified in paragraph 3.6.

##### 4.2 **Requalification testing**

If changes significantly affecting form, fit or function are made to product or manufacturing process, product assurance shall coordinate requalification testing, consisting of all or part of original testing sequence as determined by product, quality and reliability engineering.

##### 4.3 **Acceptance**

Acceptance is based upon verification that product meets requirements of paragraph 3.4. Failures attributed to equipment, test set-up, applied customer components or operator deficiencies shall not disqualify the product. If product failure occurs, corrective action shall be taken and samples resubmitted for requalification. Testing to confirm corrective action is required before resubmittal.

##### 4.4 **Quality conformance inspection**

Applicable TE Connectivity quality inspection plan will specify sampling acceptable quality level to be used. Dimensional and functional requirements shall be in accordance with applicable product drawing and this specification.